

"QUALITY PUMPS SINCE 1939"

Product information presented here reflects conditions at time of publication. Consult factory regarding discrepancies or inconsistencies.

ZOELLER
PUMP CO.



SECTION: 2.20.025

FM1722

1009

Supersedes

1108

MAIL TO: P.O. BOX 16347 • Louisville, KY 40256-0347
SHIP TO: 3649 Cane Run Road • Louisville, KY 40211-1961
(502) 778-2731 • 1 (800) 928-PUMP • FAX (502) 774-3624

visit our web site:
www.zoeller.com

COMPARE THESE FEATURES

- 115V single phase/60 Hz, .3 HP, 3.1 Amps, 3400 RPM.
- Thermal overload protection.
- Non-corrosive engineered plastic motor housing, pump housing and base.
- No steel sheet metal parts to rust or corrode.
- All stainless steel screws, switch arm, and lower motor housing.
- Oil-free.
- 2-pole float operated mechanical switch.
- Solid buoyant polypropylene float.
- Engineered plastic impeller.
- UL Listed 9' cord with 3-prong plug.
- Maximum temperature for dewatering. 110°F (43°C).
- Passes 3/8" inch spherical solids.
- 1½" NPT discharge.
- Non-clogging vortex impeller.
- On point— 7-3/8" • Off point— 3-5/8".
- Major width - 9-1/16" • Height - 11-13/16".

ZOELLER
PUMP CO.



Manufacturers of . . .

"QUALITY PUMPS SINCE 1939"

ALL MODELS ARE
COMPLETELY SUBMERSIBLE
HERMETICALLY SEALED

Watertight - dust tight.

Model 72
(For Pump Prefix Identification
see News & Views 0052)

"AQUA-MATE"
SUBMERSIBLE PUMP
FOR
DEWATERING (SUMP)



PASSES 3/8" SPHERICAL SOLIDS
1½" NPT DISCHARGE



AUTOMATIC
MODEL



MODELS AVAILABLE
• Automatic or Nonautomatic



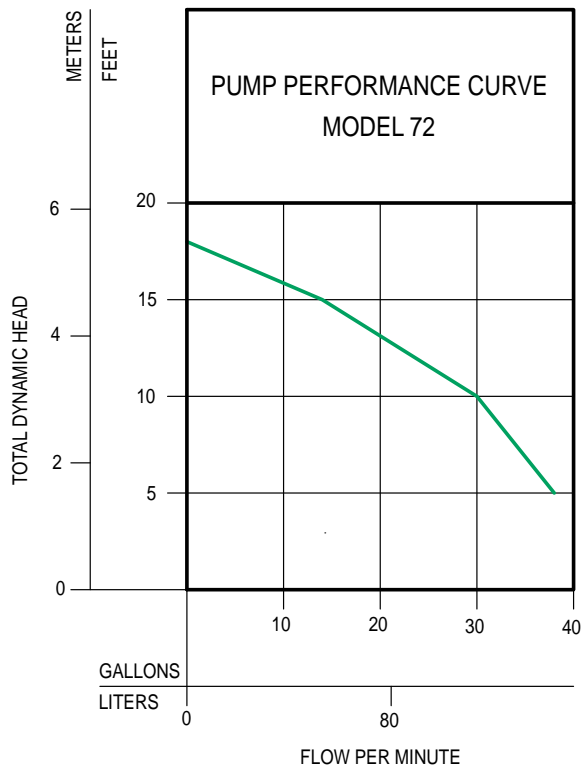

MODEL		72	
Feet	Meters	Gal.	Liters
5	1.5	38	144
10	3.0	30	114
15	4.6	14	53
Shut-off Head:		18 ft. (5.5 m)	

012051A

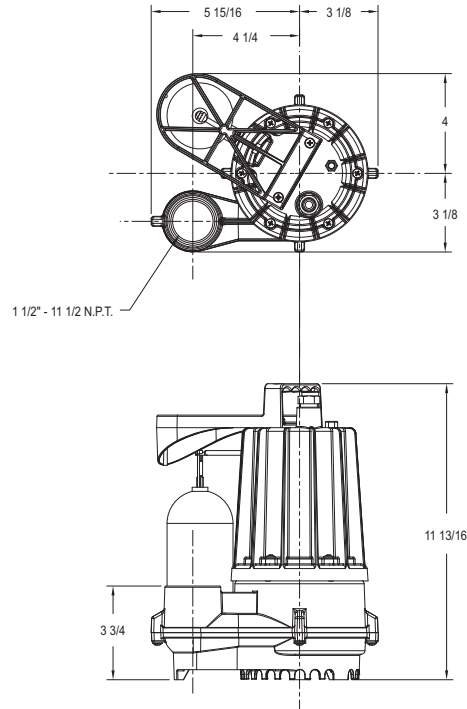

SK1924

CONSULT FACTORY FOR SPECIAL APPLICATIONS

- Variable level Float Switches available.
- Variable level long cycle systems available.
- Alarm systems available.
- Duplex systems available.

Single Seal	Control Selection			
Model	Volts - Ph	Mode	Amps	Simplex
M72	115 1	Auto	3.1	1
N72	115 1	NonAuto	3.1	2
BN72	115 1	Auto	3.1	*

*Single piggyback switch included.

SELECTION GUIDE

1. Integral float operated mechanical switch, no external control required.
2. Single piggyback variable level float switch or double piggyback variable level float switch. Refer to FM0477.

For information on additional Zoeller products refer to catalog on Piggyback Variable Level Float Switches, FM0477; Electrical Alternator, FM0486; Mechanical Alternator, FM0495; Sump/Sewage Basins, FM0487; and Single Phase Simplex Pump Control/Alarm Systems, FM0732.

CAUTION

All installation of controls, protection devices and wiring should be done by a qualified licensed electrician. All electrical and safety codes should be followed including the most recent National Electrical Code (NEC) and the Occupational Safety and Health Act (OSHA).

"Easy assembly"
(pump & discharge pipe not included.)

OPTIONAL PUMP STAND P/N 10-2421

- Reduces potential clogging by debris.
- Replaces rocks or bricks under the pump.
- Made of durable, noncorrosive ABS.
- Raises pump 2" off bottom of basin.
- Provides the ability to raise intake by adding sections of 1 1/2" or 2" PVC piping.
- Attaches securely to pump.
- Accommodates sump, dewatering and effluent applications.

NOTE: Make sure float is free from obstruction.

RESERVE POWERED DESIGN

For unusual conditions a reserve safety factor is engineered into the design of every Zoeller pump.