

Gas Conversion Kit

Gas type adjustment



DANGER: Personal injury and property damage

- ▶ This conversion shall only be installed by a qualified service agency in accordance with the manufacturer's instructions and all applicable codes and requirements of the authority having jurisdiction.
- ▶ If the information in these instructions is not followed exactly or the installation, adjustment, modification, operation or maintenance is carried out by an unqualified person, a fire, an explosion or production of carbon monoxide may result causing property damage, personal injury or loss of life.
- ▶ Before carrying out electrical work: disconnect the installation from the power supply.
- ▶ The qualified service agency is responsible for the proper conversion of this appliance.
- ▶ The installation is not proper and complete until the operation of the converted appliance is checked as specified in these instructions.

The gas-air ratio must always be set on the basis of a CO₂ or O₂ reading taken at maximum nominal output and minimum nominal output using an electronic flue gas analyzer.

Adjustment to different flue systems using throttle discs or baffles is not necessary.

NG

- Appliances are set at the factory to Wobbe index 1,333 BTU/ft³ (49.6 MJ/m³) at 60 °F (approx. 15 °C), 30" HG and 7.0" W.C. (17.4 mbar) gas supply pressure and then sealed.

Converting to a different gas type



DANGER: Explosion!

- ▶ Close the gas cock prior to working on the gas train.
- ▶ Check for gas leaks after carrying out work on the gas train.

A gas conversion kit is included in the scope of delivery.

- ▶ Fold the Heatronic down.
- ▶ Check the number on the code plug from the gas conversion kit:

| Appliance | NG Code plug Order number | LPG Code plug Order number |
|-----------|------------------------------|-------------------------------|
| ZBR16-3A | 8 714 432 501 | 8 714 432 506 |
| ZBR28-3A | 8 714 432 502 | 8 714 432 507 |
| ZBR35-3A | 8 714 432 503 | 8 714 432 508 |
| ZBR42-3A | 8 714 432 504 | 8 714 432 509 |
| ZWB28-3A | 8 714 432 520 | 8 714 432 521 |
| ZWB42-3A | 8 714 432 500 | 8 714 432 505 |

- ▶ Replace the code plug in the Heatronic with the code plug from the gas conversion kit.

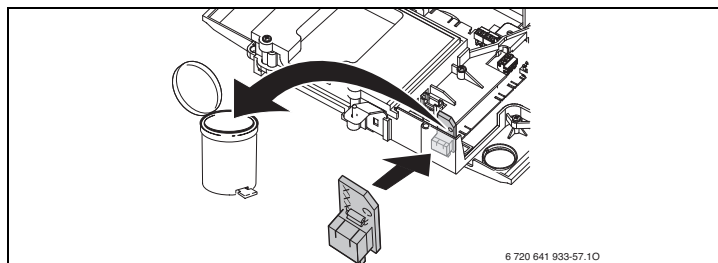

Fig. 1 Replacing the code plug

- ▶ Affix the gas type label from the gas conversion kit to the appliance.

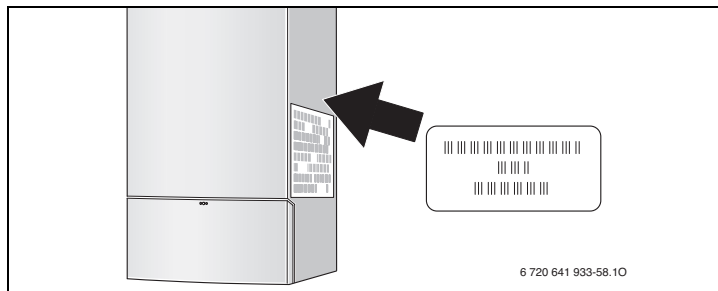

Fig. 2 Affixing the gas type label

- ▶ Always adjust the gas-air ratio (CO₂ or O₂, → Section "Setting the gas-air ratio") after converting to a different gas type and measure the CO content of the flue gas (→ "Installation and Service Instructions for Contractors").

Installation location higher than 2,000 feet (610 m) above sea level

Input and output rates will be reduced at high altitudes.

ZBR42-3A... and ZWB42-3A... have a derate of approximately 3 % per 1000 feet (305 m).

ZBR16-3A..., ZBR28-3A..., ZBR35-3A... and ZWB28-3A... do not have a derate up to 6000 feet (1829 m). Above 6000 feet (1829 m) the derate is approximately 3 % per 1000 feet (305 m).



The wall mounted condensing gas boiler is set at the factory for installation below 2000 feet (610 m) above sea level.

- ▶ Correction of the fan speed curve of the burner:
Use service function 0.d to adjust the elevation setting.

Setting the gas-air ratio (CO₂ or O₂)

- ▶ Switch the appliance OFF using the ON/OFF switch.
- ▶ Remove the cover (→ "Installation and Service Instructions for Contractors").
- ▶ Switch the appliance ON using the ON/OFF switch.
- ▶ Open one of the flue gas test ports.

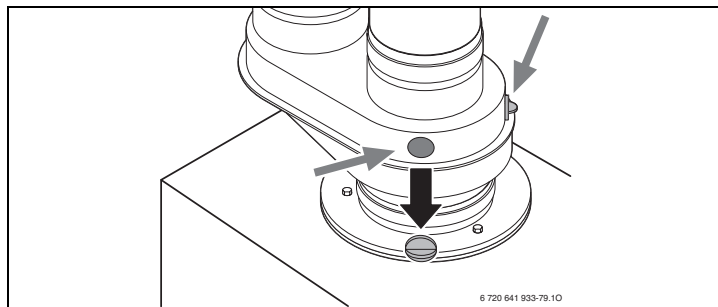

Fig. 3 Open one of the flue gas test ports







BOSCH

Bosch Thermotechnik GmbH
Junkersstrasse 20-24; D-73249 Wernau/Germany

6 720 646 558 (2010/11)

Gas Conversion Kit

- ▶ Insert the flue gas probe approx. 2 3/4 inches (70 mm) into the test port and seal around it.
- ▶ Press and hold the emissions test button  until it lights up. The display shows the supply temperature alternating with  = **maximum set output in heating mode**.
- ▶ Briefly press the emissions test button . The display shows the supply temperature in alternation with  = **maximum nominal output**.
- ▶ Measure the CO₂ or O₂ level and the CO content of the flue gas (→ "Installation and Service Instructions for Contractors").
- ▶ On the the gas throttle break the seal at the slot and remove the cap.

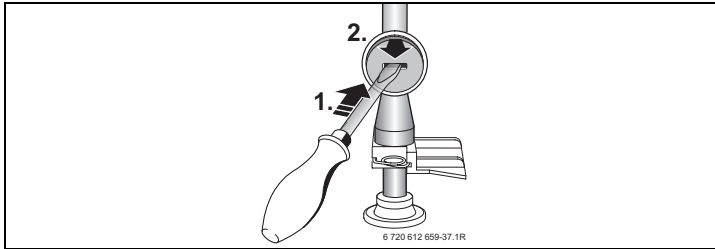

Fig. 4 Remove seal from the gas throttle

- ▶ Adjust the gas flow throttle to set the CO₂ or O₂ level for maximum nominal output according to the following table:

| Gas type | Maximum nominal output | | Minimum nominal output | |
|---------------|------------------------|----------------|------------------------|----------------|
| | CO ₂ | O ₂ | CO ₂ | O ₂ |
| NG | 9.4 % | 4.0 % | 8.6 % | 5.5 % |
| LPG (propane) | 11.0 % | 4.2 % | 10.4% | 5.1 % |

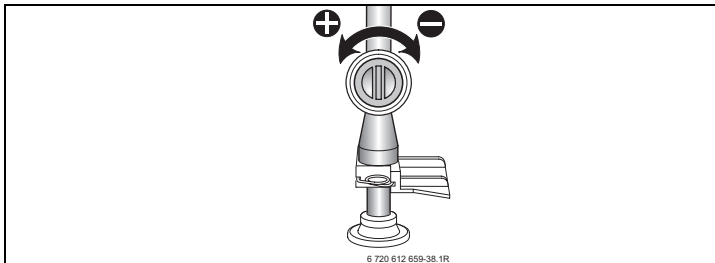



Fig. 5 Set maximum nominal output

- ▶ Briefly press the emissions test button .
- ▶ The display shows the supply temperature in alternation with  = **minimum nominal output**.
- ▶ Measure the CO₂ or O₂ level.
- ▶ Remove the sealed screw (→ Fig. 6, [3]) from gas valve adjustment screw (→ Fig. 6, [2]) and set CO₂ or O₂ level for minimum nominal output.

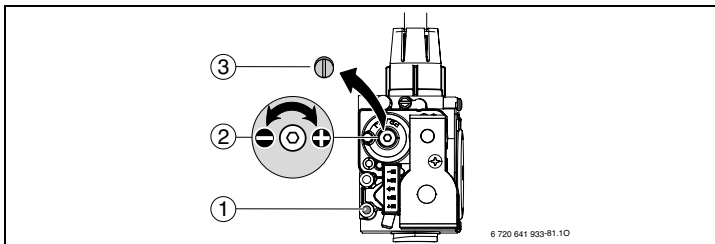



Fig. 6 Set minimum nominal output

- ▶ Re-check settings at maximum and minimum nominal output and re-adjust if necessary.

- ▶ Repeatedly press the emissions test button  until the light goes out. The display returns to the supply temperature.
- ▶ Record the CO₂ or O₂ levels and the CO content of the flue gas in the commissioning log.
- ▶ Reinstall the screw (→ Fig. 6, [3]) to cover the gas valve adjustment screw.
- ▶ Remove flue gas probe and close the flue gas test port properly.

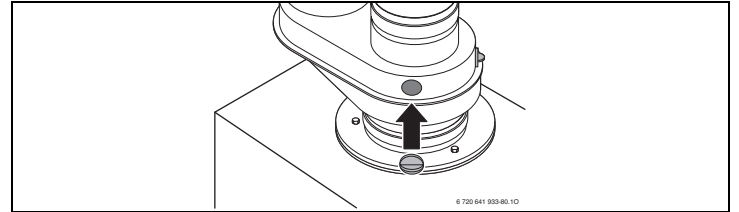

Fig. 7 Close flue gas test ports

Check gas supply dynamic pressure

- ▶ Switch the appliance OFF and close the gas shut-off valve.
- ▶ Loosen the screw in the test port for gas inlet pressure (→ Fig. 6, [1]) and connect a pressure gauge (→ Fig. 8).

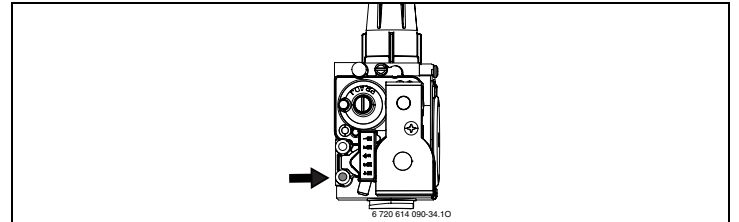







Fig. 8 Check inlet gas pressure

- ▶ Turn on the gas cock and switch the appliance ON.
- ▶ Press and hold the emissions test button  until it lights up. The display shows the supply temperature alternating with  = **maximum set output in heating mode**.
- ▶ Briefly press the emissions test button . The display shows the supply temperature in alternation with  = **maximum nominal output**.
- ▶ Check the required gas inlet pressure according to the following table:

| Gas type | Permissible pressure range for maximum nominal output | |
|---------------|---|---------------------|
| | Nominal pressure " W.C. (mbar) | " W.C. (mbar) |
| NG | 7 (17.4) | 3.5-10.5 (8.7-26.1) |
| LPG (propane) | 11 (27.4) | 8-13 (19.9-32.3) |



Do not operate the appliance if the measured value is below or above these values. Determine the cause and eliminate the fault. If this is not possible, block the appliance on the gas side and notify the gas supplier.

- ▶ Repeatedly press the emissions test button  until the light goes out. The display returns to the supply temperature.
- ▶ Switch the appliance OFF, turn off the gas cock, remove the pressure gauge and tighten the screw in the test port for gas inlet pressure.
- ▶ Reinstall the cover.