



YJ-LTE™ Oil-Less Universal Refrigerant Recovery System



Operation and Maintenance Manual

(English and Spanish. French and German available at www.yellowjacket.com)

IMPORTANT NOTICE TO PURCHASER

Check for damage immediately. Prior to shipment, all YELLOW JACKET *YJ-LTE* Refrigerant Recovery Systems are completely tested and inspected to assure compliance with Ritchie Engineering factory specifications.

If the recovery system carton is damaged, check contents immediately. Note damage on shipper's Bill of Lading and have shipper sign statement. Notify carrier immediately of the damage to arrange inspection of the recovery system and packaging. The CARRIER ALONE is responsible for han-

dling and settling your claim. Ritchie Engineering will cooperate in assessing damage if the recovery system is returned to the factory prepaid.

Carton contents include:

- *YJ-LTE* Refrigerant Recovery System
- Quick Start Guide
- Important Safety Information

To validate warranty, registration online at www.yellowjacket.com/xxxx within 10 days.

Table of Contents

	Page
General Safety Instructions	2-3
Direct Liquid/Vapor Recovery	3-4
Push-Pull Liquid Recovery	4-5
Purging the YJ-LTE	5
Recovery Tips & Techniques	6
Wiring Diagram	6
Technical Data	7
Warranty	8

General Safety Instructions

- 1) Know your equipment.** Read and understand the operation manual and the labels affixed to this unit. Learn the applications and limitations, as well as the specific potential hazards of the *YJ-LTE*.
- 2) Use the correct hoses.** Use only hoses designed for handling of refrigerants. The hose should be the minimum length required for each job and equipped with a shut-off device (such as the compact ball valve) at the end to reduce the likelihood of refrigerant leaks to the atmosphere. For best performance we recommend using 3/8" hoses. *YELLOW JACKET hoses are made for almost every type of refrigerant. See your local distributor for more information.*
- 3) Ground all equipment.** Plug the *YJ-LTE* into a properly grounded receptacle.
- 4) If the power cord is damaged,** it must be replaced by a cord assembly available from the manufacturer or distributor where purchased.
- 6) Do not pressure test with compressed air.** Some mixtures of air and refrigerant have been shown to be combustible at elevated pressures.
- 7) Avoid dangerous environments.** To keep operator exposure to a minimum, use the *YJ-LTE* only in areas with sufficient ventilation.

Recovery should always be performed in well ventilated areas. Use the *YJ-LTE* only in locations where mechanical ventilation which provides at least four air changes per hour is present, or place the unit 18" above the floor during use.

The *YJ-LTE* should not be used near open containers of gasoline or any other flammable

liquid. Do not allow refrigerants to come in contact with open flame. Refrigerant decomposition in flame can result in the formation of hydrofluoric acid or phosgene gas. Always wear safety goggles and gloves. Personal protective equipment should be worn to protect operator from frostbite.

- 8) **Use caution when connecting or disconnecting.** Improper usage may result in refrigerant burns (frostbite). If a major leak occurs, proceed immediately to a well ventilated area.
- 9) **Disconnect recovery machine from power before servicing.** An electrical shock hazard is present when the unit is disassembled.
- 10) **Repair damaged parts.** Do not operate the *YJ-LTE* if there is a defective part. Repair the unit to proper operating conditions before further use.
- 11) **Use recommended accessories.** Follow the instructions that accompany all acces-

sories. Improper use may damage equipment or create a hazard.

- 12) **Use the *YJ-LTE* only with the proper refrigerants.** (See specifications for a complete list of compatible refrigerants.)
- 13) **Operate the *YJ-LTE* within the design parameters only.** The *YJ-LTE* was designed to operate within a temperature range of 40° (4° C) to 120°F (49° C). Do not operate in a wet location.

Caution: All refrigerant hoses, recovery tanks, refrigerant lines, other vessels containing refrigerants and the *YJ-LTE* should be handled as if under high pressure. When opening a tank containing refrigerant, open valves slowly to prevent release of refrigerant, especially if the valves might be damaged.

To prevent the risk of fire DO NOT use an extension cord longer than 50' (15 m) and a minimum of 16 AWG (1.276 mm²), 3 conductor grounded.

Direct Liquid/Vapor Recovery

Refer to the following instructions and the diagram below:

1. Know the type and quantity of refrigerant present before servicing any system.
2. Turn off power to the system being serviced.
3. Connect your manifold to the system being serviced. High side to liquid port and low side to vapor port as shown in diagram.

4. NOTE – For best performance, use minimum length and maximum diameter hose(s) between the *YJ-LTE* recovery machine and the system. The recovery hose at the system vapor port connection must also have a depressor for final system purge. In addition, using a low loss hose for this connection will minimize the amount of air drawn in during the purge process.

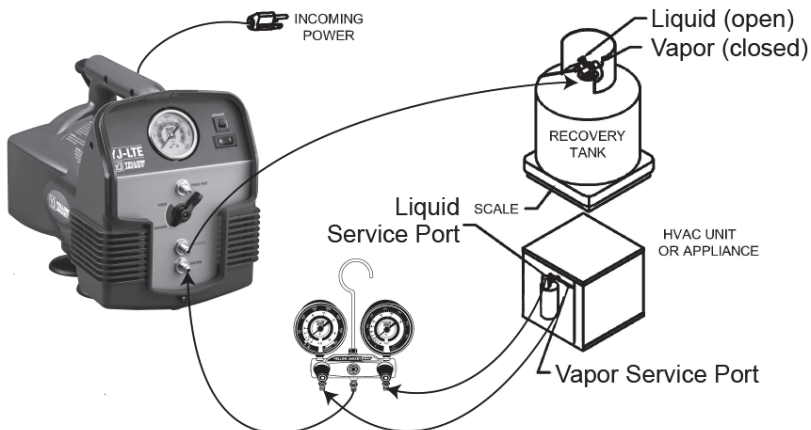

5. Connect the recovery hose from system or utility port of your manifold to the 1/4" SUCTION port of the YJ-LTE.
6. Connect the hose from the recovery cylinder (liquid side) to the 1/4" DISCHARGE port of the YJ-LTE.
7. Purge all hoses of non-condensable gasses before recovering refrigerant into recovery cylinder.
8. Open the liquid valve on the recovery tank.
9. Ensure valve is in recover position. Turn the YJ-LTE on.
10. Open the utility valve and then slowly open the high side first to recover as much liquid as possible, then open low side and on your manifold. If severe vibration, knocking or lugging of the motor is noticed, it is recommended to partially close the service manifold valves briefly.
11. When the manifold pressure gauge indicates the appropriate vacuum level recovery is complete.

YJ-LTE Push-Pull Liquid Recovery

The Push-Pull Liquid Recovery mode is used for transferring large volumes of liquid refrigerant. The YJ-LTE "pulls" vapor from the recovery cylinder and produces high pressure discharge gas that "pushes" liquid out of the HVAC system and into the recovery cylinder. Some HVAC systems will not allow for the push-pull recovery method. If any of the following conditions apply, do not use push-pull method, but follow the Liquid-Vapor Recovery instructions:

- System contains less than 10 pounds of refrigerant.
- System is a heat pump or other unit with a reversing valve.
- System has an accumulator between the service ports used in liquid recovery.

- The refrigerant system does not allow for the formation of a solid column of liquid.

For push-pull recovery, a sight glass is monitored during recovery. When liquid is no longer visible, stop recovery and finish recovering using the Liquid-Vapor Recovery process. For complete recovery, the system must be pulled into a vacuum as required by EPA standards.

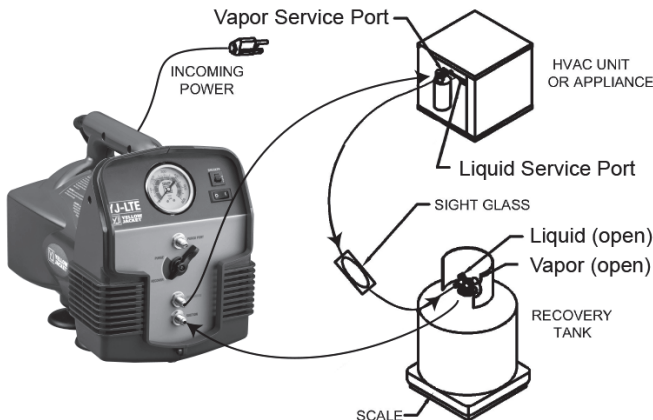

The push-pull process requires the following:

1. Proper hoses for all connections. Hoses with low loss fittings or valves are recommended.
2. A recovery cylinder with adequate capacity.
3. A sight glass (Note: Make sure sight glass is rated for the pressure of the refrigerant being recovered).

Follow these steps:

1. Turn off power to the system being serviced.
2. Hook up YJ-LTE, the system to be recovered, and the recovery tank as shown in the diagram to the left.
3. Purge all hoses of non-condensables before recovering refrigerant into recovery cylinder.
4. Open valves on the recovery tank.
5. Turn the selector valve to PURGE position. Note – This position allows the compressor discharge to bypass the unit condenser. This higher temperature feed gas

will allow a faster liquid recovery.

6. Turn YJ-LTE on. If starting with an evacuated recovery cylinder allow as much liquid as possible to flow before starting recovery unit. Note - Gauge will not reflect system pressure.
7. Monitor the sight glass. When the passing liquid is no longer visible through the sight glass, the push-pull method of recovery is complete.
8. Close the VAPOR valve on the recovery tank and let the recovery continue briefly.
9. Close SYSTEM VALVES and LIQUID valve on recovery tank.
10. Reconnect the hoses per the diagram under “Direct Liquid or Vapor Recovery.”
11. Rotate the selector valve to the RECOVER position, open required system and tank valves and restart unit to recover vapor.
12. Continue recovery until the unit reaches the appropriate level of vacuum.
13. Perform PURGE procedure.

Purging the YJ-LTE

1. Close all system valves.
2. Close valves on system hoses.
3. Connect the system vapor recovery hose or blue manifold hose to the PURGE port on the YJ-LTE. This hose must have a valve depressor for opening the purge port Schrader valve.
4. Turn the YJ-LTE valve to the PURGE

position, open the recovery/blue hose valve, and turn the unit on.

5. When the pressure gauge indicates the appropriate vacuum level, the purge process is complete.
6. Close the valve on recovery discharge hose and the recovery tank. Shut off the YJ-LTE.

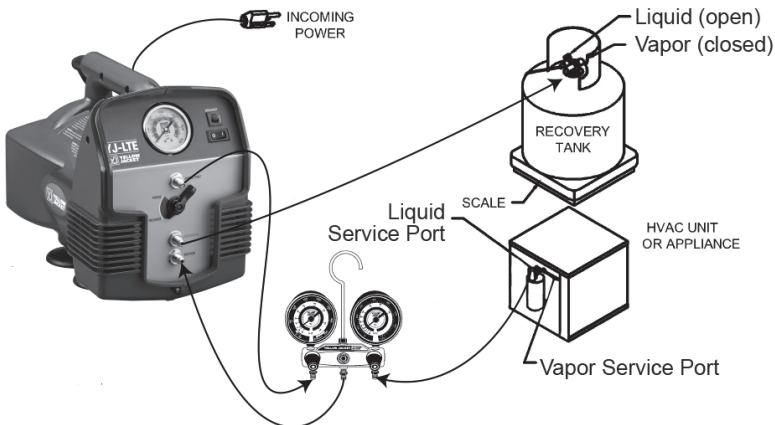

Recovery Tips and Techniques

- 1) To assure the fastest and quickest recovery possible, use the shortest hoses possible and use hoses with Schrader depressors only where necessary.
- 2) Know what kind and the amount of refrigerant that is going to be recovered. This is critical to avoid contamination and know how much refrigerant will be recovered. The first job of the day usually means a fresh, empty tank and no cause for worry about over-filling. However, the last job of the day means there is already liquid in the tank and over-filling can be a concern. Over-filling a recovery cylinder can have disastrous results.
- 3) Refrigerant responds to heat. Therefore, a significant increase in the speed of the recovery process will be obtained if a heat gun is used, specifically to any spots where liquid may have accumulated.
- 4) If recovering large amounts of refrigerant (20 lbs or more), the push-pull method is recommended. **(Note: This process requires the hoses to be switched before recovery of the remaining vapor.)**
- 5) Recovery can often be speeded up by simultaneous recovery from both the high and low side of the system. Attach short hoses to both the high and low side of the system and join them with a BRUTE™ II Manifold or Y connector to the hose going to the Suction Port of the *YJ-LTE*.

Recovery machines are not vacuum pumps. For proper evacuation, use a YELLOW JACKET SuperEvac™ vacuum pump. To speed up the evacuation process, use the SuperEvac vacuum pump and a core removal tool (Part #18975). For more information contact your YELLOW JACKET wholesaler.

Wiring Diagram

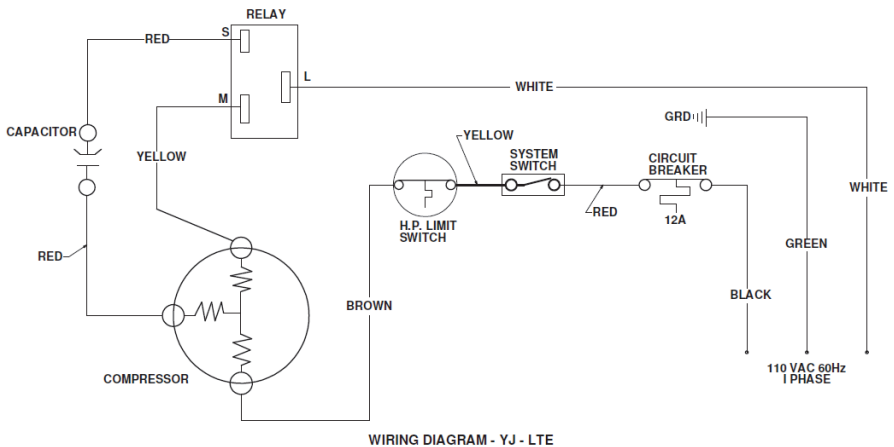

Technical Data

Compressor:	1/2 HP Twin Cylinder Reciprocating Oil-Less	
Power Source:	115V AC 60 Hz 1 Phase	230V AC 50 Hz 1 Phase
Amperage:	8.0	4.0
High Pressure Shut-Off:	517 psi—auto restart	517 psi—auto restart
Vacuum Rating:	13" @ 400 psi discharge	13" @ 400 psi discharge
Size:	Height:	11.5"
	Width:	9.0"
	Depth:	13.5"
	Weight:	24 Lbs.

**UL Certified Rates to ARI Standard 740-98*

YJ-LTE	R-134a	R-22	R-407C	R-410A
Vapor lbs./min				
Liquid lbs./min				
Push-Pull lbs./min				
Vacuum Level				

Other Refrigerants - The **YJ-LTE** is approved for use with the following refrigerants which have not been certified for a particular recovery rate: R-12, R-114, R-401A, R401B, R-401C, R-402A, R-402B, R-404A, R-406A, R-407A, R-407B, R-407D, R-408A, R-409A, R-411A, R-411B, R-412A, R-500, R-502, R-507A and R509A.

Warranty Information

Note: All units must be shipped to an authorized repair center for repair. If at any time after the warranty period you have problems with your YELLOW JACKET recovery

unit, call our technical service department for help in selecting the correct replacement parts, or to arrange for its repair at reasonable costs.

Ritchie Engineering guarantees YELLOW JACKET products to be free of defective material and workmanship which could affect the life of the product when used for the purpose for which it was designed. Warranty does not cover items that have been altered, abused or returned solely in need of field service maintenance.

The YELLOW JACKET YJ-LTE recovery system (UPC 95730) is covered by a one year warranty for parts and labor. The warranty also allows for over-the-counter exchange, when applicable. To receive the over-the-counter exchange, call Ritchie Engineering Customer Service at (800)769-8370 and get the required authorization number.

Failure to get the required authorization number could result in a denial of the over-the-counter exchange.

The following exceptions will not be covered under this warranty: Recovery products that have been altered, misused, or improperly maintained.

The following must be done before returning unit:

- 1) Call our technical service personnel at (800) 769-8370 to assess if the problem can be resolved over the phone.
- 2) Obtain an RGA number from Ritchie Engineering for the return of the product.
- 3) Fax a copy of the original invoice to (800) 322-8684.

YELLOW JACKET Products Division
Ritchie Engineering Co., Inc.
10950 Hampshire Avenue South
Bloomington, MN 55438
e-mail: custserv@yellowjacket.com
Web Site: www.yellowjacket.com
Phone: 800-769-8370
Int'l Phone: 952-943-1333
Fax: 800-322-8684
Int'l Fax: 952-943-1605

