

⚠ WARNING

Replacement parts must be purchased through a local Triangle Tube distributor. When ordering part please provide the model number and description and/or part number of replacement part.

Use only genuine Triangle Tube replacement parts to ensure warranty coverage and to avoid damage to appliance and improper operation of appliance. Contact Triangle Tube at 856-228-8881 or www.triangletube.com for list of distributors nearest you.

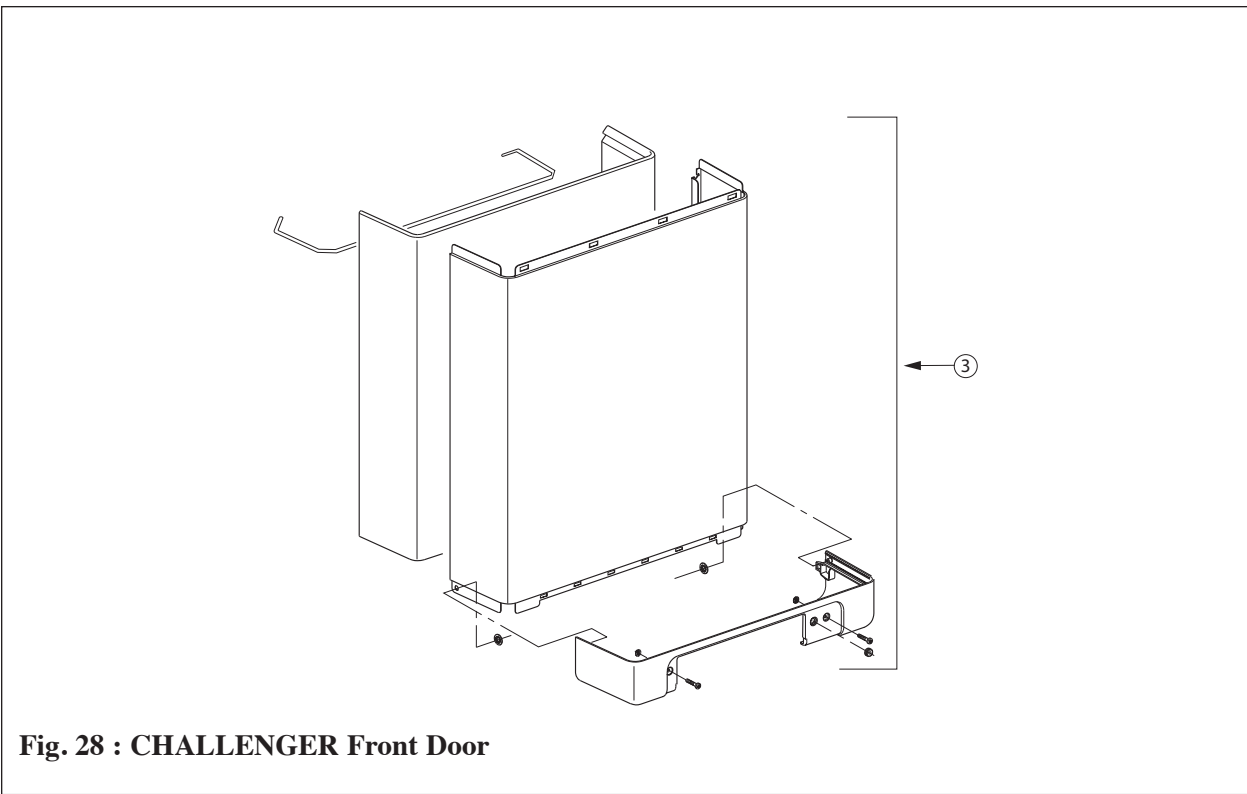

Fig. 28 : CHALLENGER Front Door

Item	Part Number CC85s	Part Number CC105s	Part Number CC125s & CC150s	Description
1		CCRKIT04		Wall Bracket Assembly (Not Shown)
2		CCRKIT05		Pipe Connectors & Brackets Assembly (Not Shown)
2A		CCFTG01		Connector Pipe CH (Not Shown) - 1/Kit
3	CCRKIT06	CCRKIT07	CCRKIT08	Front Door Assembly

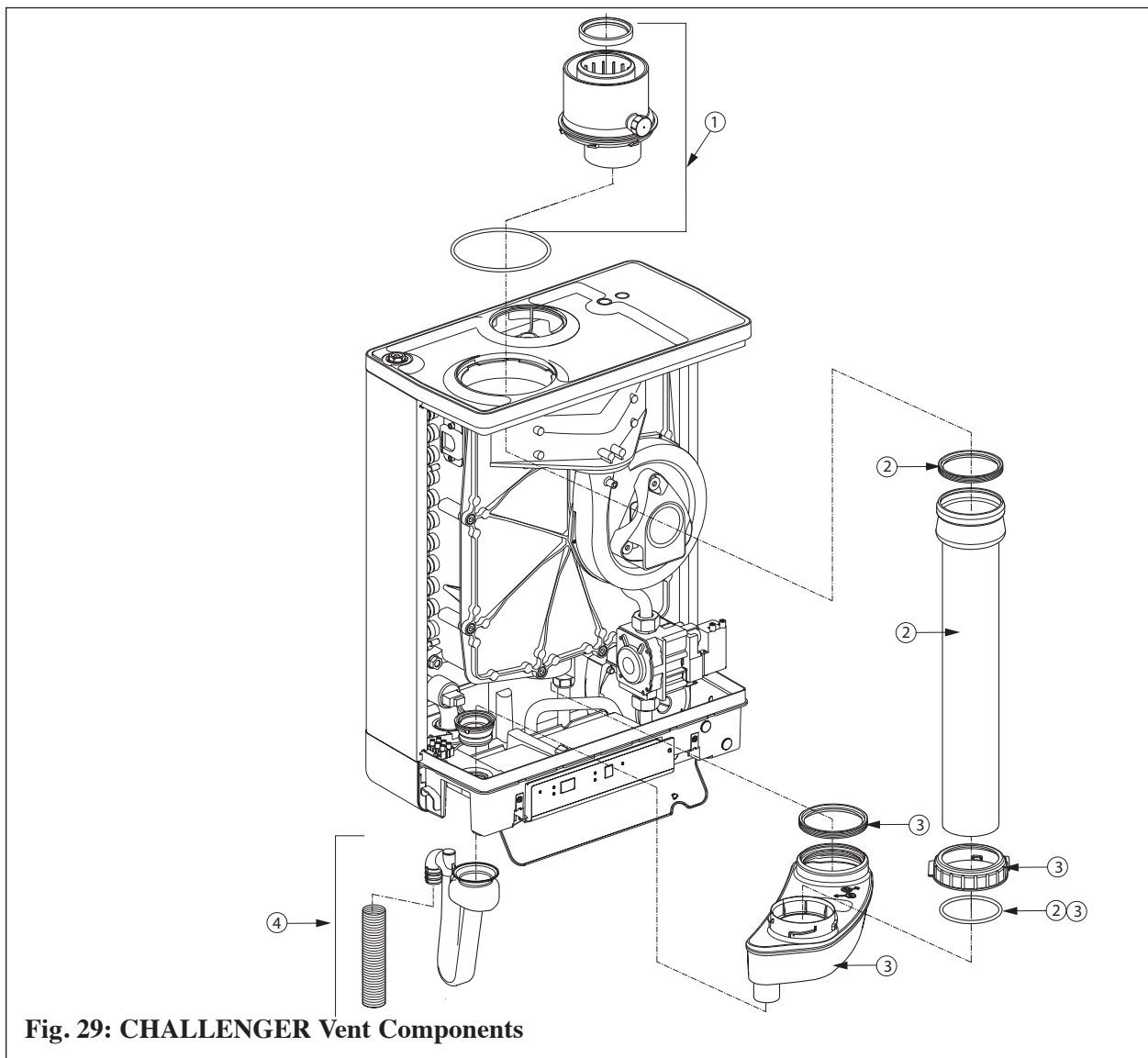
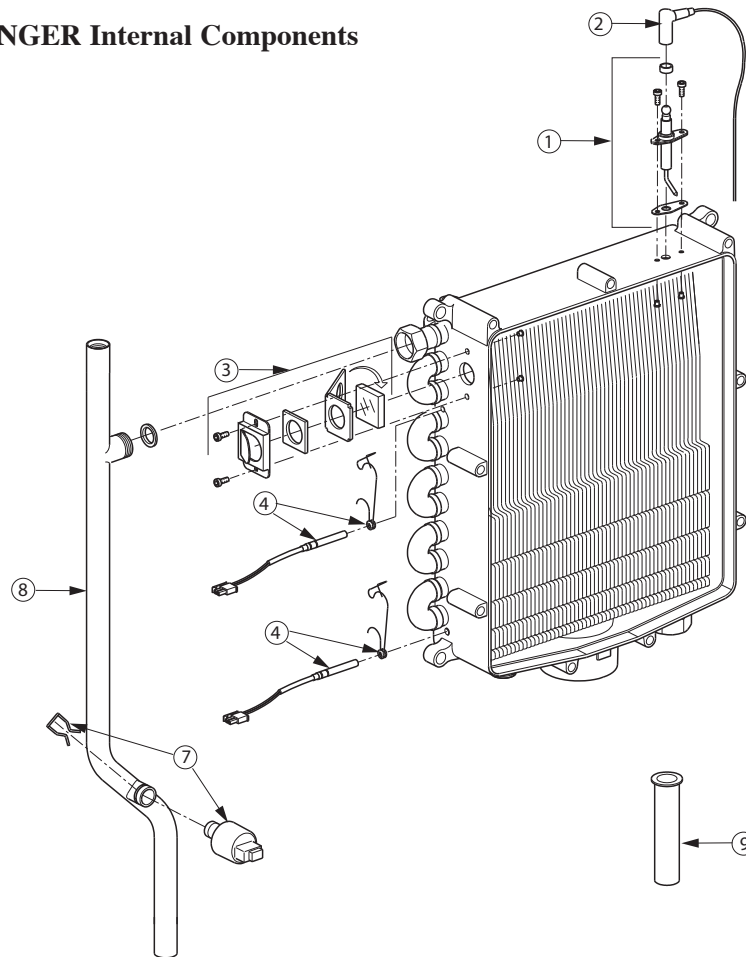

Fig. 29: CHALLENGER Vent Components

Item	Part Number CC85s	Part Number CC105s	Part Number CC125s	Part Number CC150s	Description
1	CCRKIT09				80/125 Concentric Vent /Air Adapter Assembly (optional - shown)
	CCRKIT35				3" Vent/Air Adaptor Assembly (standard -not shown)
2	CCRKIT10	CCRKIT11	CCRKIT12		Vent Assembly
3	CCRKIT13				Condensate Collector Assembly
4	CCRKIT14			CCRKIT36	Condensate Drain Trap Assembly

Fig. 30 : CHALLENGER Internal Components



Item	Part Number CC85s	Part Number CC105s	Part Number CC125s & CC150s	Description
1		CCRKIT15		Igniter Assembly
2		CCCLB01		Ignition Cable
3		CCRKIT16		Sight Glass Assembly
4		CCRKIT17		CH Sensor Assembly - 1 / Kit
7		CCRKIT19		LWCO/CH Pressure Sensor Assembly
8	CCRKIT20	CCRKIT21	CCRKIT22	CH Supply pipe Assembly
9		CCRKIT23		CH Return Pipe Assembly

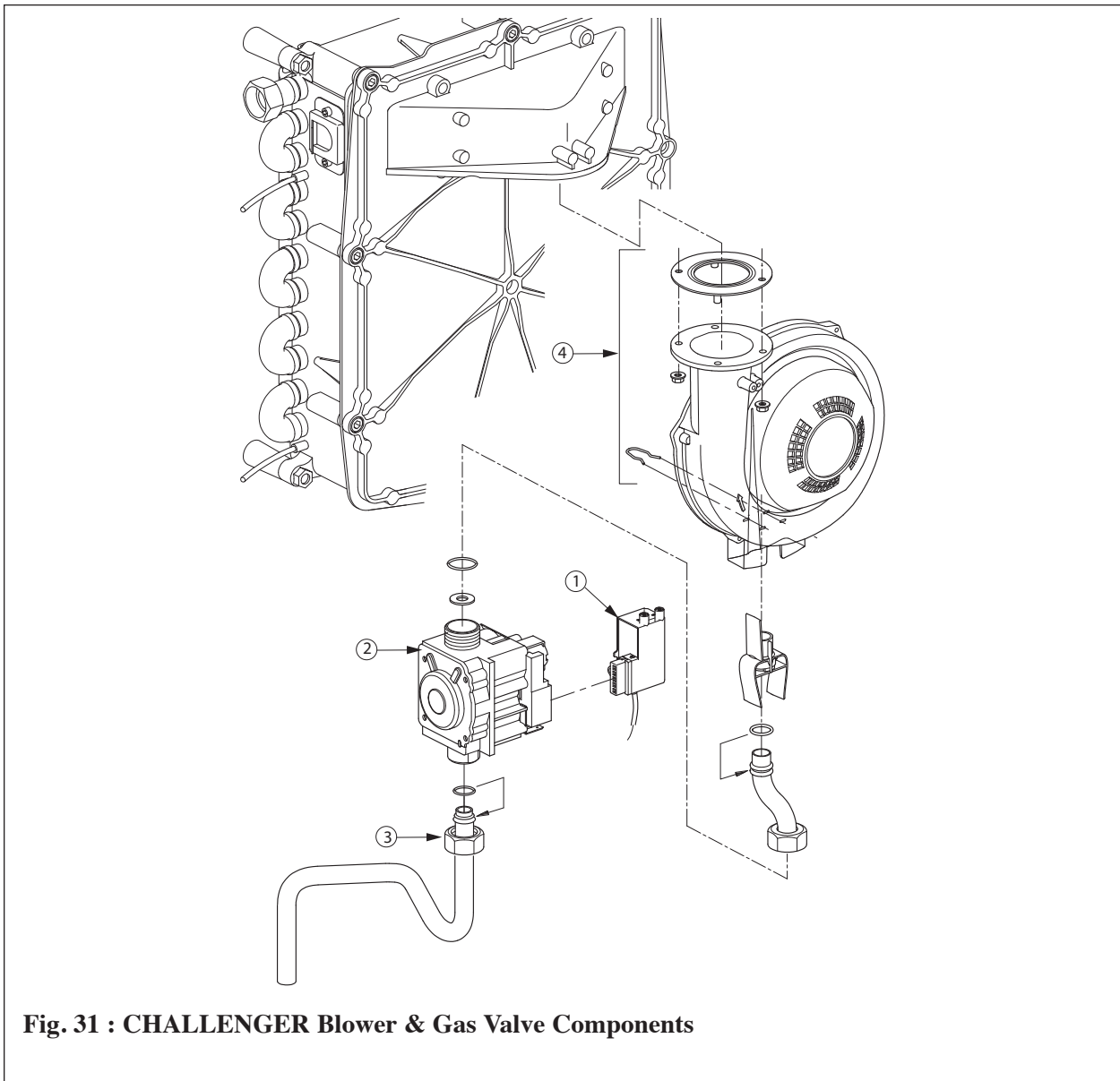

Fig. 31 : CHALLENGER Blower & Gas Valve Components

Item	Part Number CC85s	Part Number CC105s	Part Number CC125s & CC150s	Description
1		CCRKIT28		Ignition Transformer Assembly
2		CCRKIT29		Gas Valve Assembly
3	CCRKIT30	CCRKIT31		Gas Pipe Assembly
4		CCRKIT32		Blower Assembly

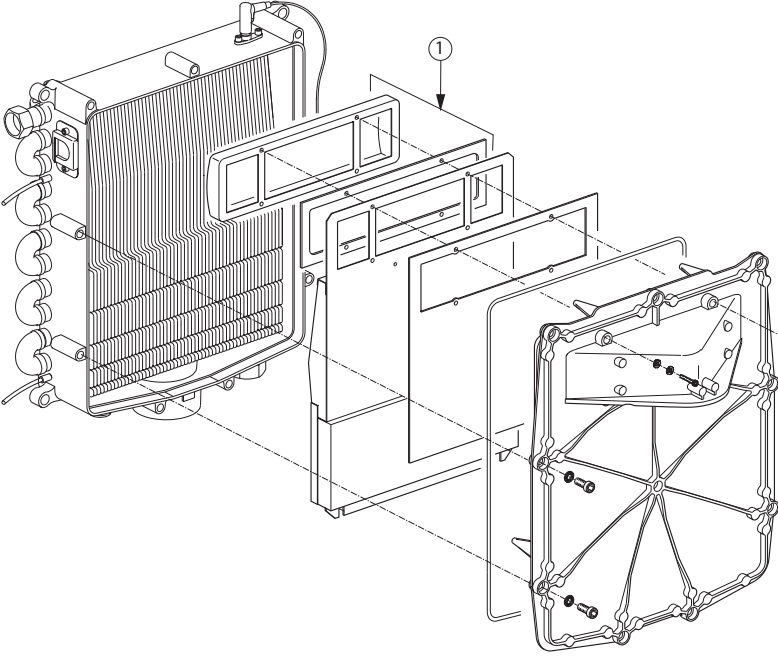

Fig. 32 : CHALLENGER Burner Components

Item	Part Number CC85s	Part Number CC105s	Part Number CC125s & CC150s	Description
1	CCRKIT33			Burner Assembly

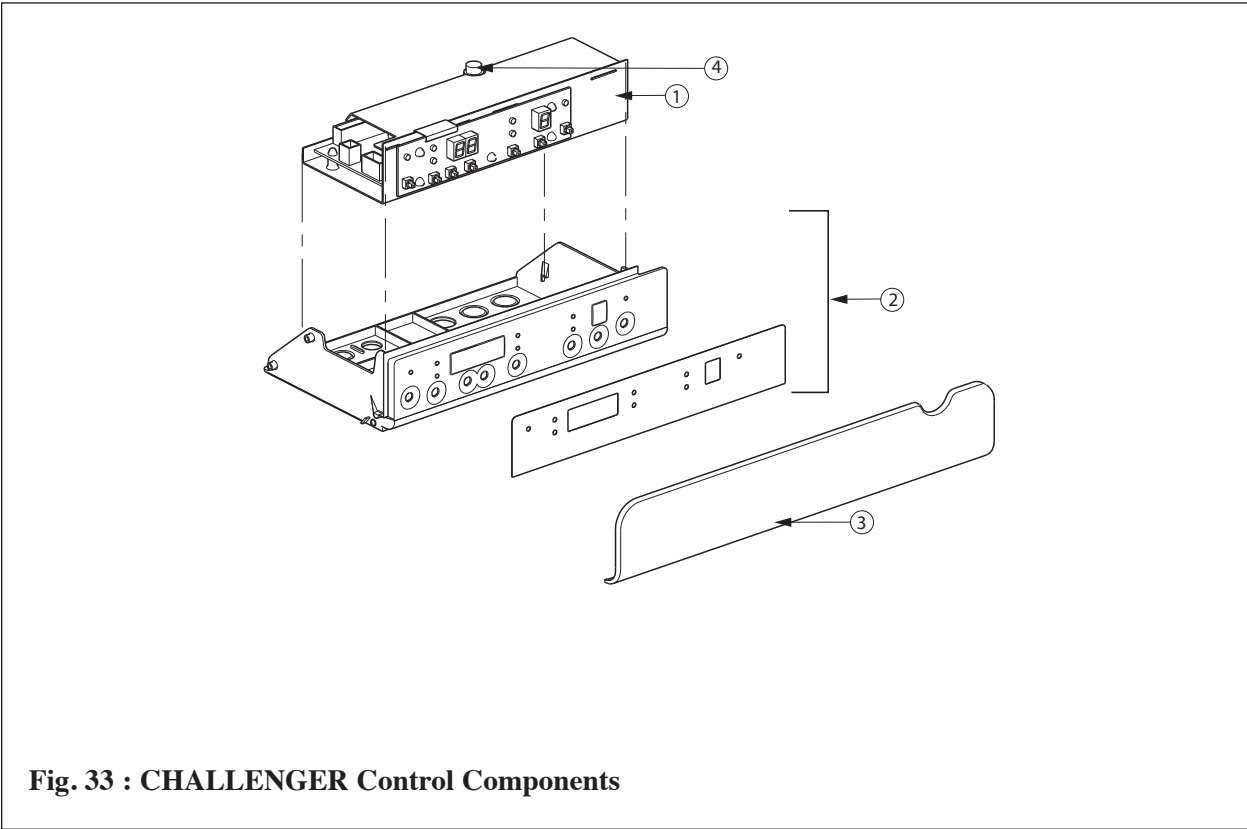

Fig. 33 : CHALLENGER Control Components

Item	Part Number CC85s	Part Number CC105s	Part Number CC125s	Part Number CC150s	Description
1	CCCON01			CCCON02	Control/Display
2	CCCS01				Housing Plastic Control
3	CCRKIT34				Flip Panel
4	CCFUSE01				Fuse - 1/Kit