

**Specification Submittal Data / Panasonic Ventilation Fan**

**Description:**

Ventilation fan/light shall be low some ceiling or wall mount rated for continuous run. Fan shall be ENERGY STAR® rated and certified by the Home Ventilation Institute (HVI). Fan shall include energy efficient compact fluorescent lighting. Evaluated by Underwriters Laboratories and conform to both UL and cUL safety standards.

**Motor/Blower:**

- Four-pole totally enclosed condenser motor rated for continuous run.
- Power rating shall be 120 volts and 60 Hz.
- Fan shall be UL and cUL listed for tub/shower enclosure when used with a GFCI protected circuit and used in insulated ceiling (TYPE I.C.).
- Motor equipped with thermal-cut-off fuse.
- Removable, permanently lubricated, plug-in motor.

**Housing:**

- Rust proof paint, galvanized steel body.
- 4" oval diameter duct.
- Optional 24 gauge steel, fire code rated 4" oval to 3" round duct adaptor sold separately (Model # FV-VS43R)
- Expandable extension bracket up to 24".
- Built in backdraft damper.
- Built-in metal flange provides blocking for penetrations through drywall as an Air Barrier, and assists with the decrease in leakage in the Building Envelope during blower door testing.
- Unique L-shaped bracket simplifies installation and provides strong support
- Built-in metal flange creates a vapor barrier.

**Light:**

- Two 13 Watt self-ballasted GU24 base compact fluorescent lamps included.

- FCC Part 18 compliant.

**Grille:**

- Attractive design using PP material.
- Attaches directly to housing with torsion springs.

**Warranty:**

- ALL Parts: 3 Years from original purchase date. CFL: 1 year Night Light: No Warranty.

**Architectural Specifications:**

Ventilation fan and light shall be ceiling or wall mount, ENERGY STAR rated, with no less than 100 CFM and no more than 1.4 sones as certified by the Home Ventilating Institute (HVI) at 0.1 wg with no less than 91 CFM and no more than 1.5 sones at .25 wg. Power consumption shall be no greater than 30.2 Watts at 0.1 wg and 30.3 Watts at 0.25 wg with efficiency of no less than 3.3 CFM/Watt at 0.1 wg and 3.0 CFM/Watt at 0.25 wg. The motor shall be fully enclosed, four pole condenser type engineered to operate continuously for no less than 30,000 hours. Power rating shall be 120v/60Hz. Duct diameter shall be no less than 4" duct. Optional 24 gauge steel, fire code rated 4" oval to 3" round duct adaptor sold separately (Model # FV-VS43R). Fan shall be UL and cUL listed for ceiling or wall mount and tub/shower enclosure when used with a GFCI protected circuit. Fan can be used to comply with ASHRAE 62.2, LEED, ENERGY STAR IAP, EarthCraft, California Title-24 and WA Ventilation Code. Lamps shall be of the compact fluorescent type and utilize no less than two 13 Watt, ESTAR rated, self-ballasted GU24 base compact fluorescent lamps. Night-light feature shall be included.

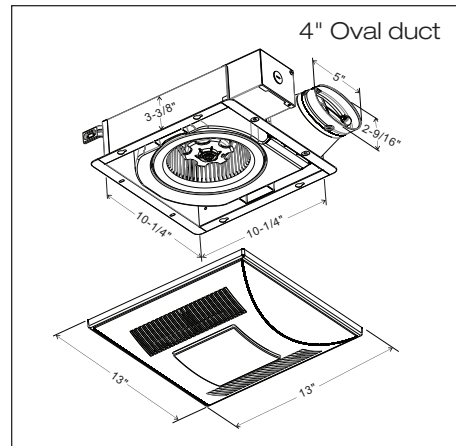

FV-10VSL3

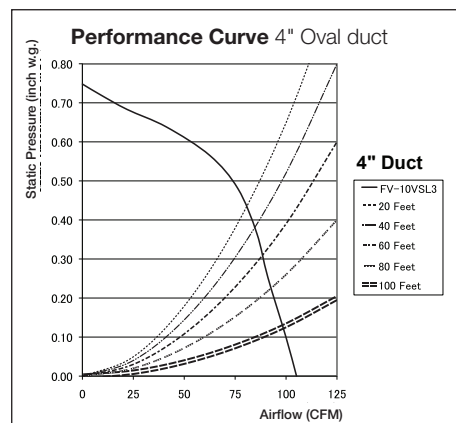

Specifications: <b>WhisperValue</b> FV-10VSL3		4" Oval Duct	
<b>Ventilation Fan Characteristics</b> (HVI Certified Data)	Static Pressure in inches w.g.	0.1	0.25
	Air Volume (CFM)	100	91
	Noise (sones)	1.4	1.5
	Power Consumption (watts)	30.2	30.3
	Energy Efficiency (CFM/Watt)	3.3	3.0
	Speed (RPM)	918	1087
	Current (amps)	0.26	0.26
	Power Rating (V/Hz)	120/60	
	ENERGY STAR rated	YES	



(2) 13W self-ballasted GU24 base CFL lamps included

0.25=Installed Performance

For complete Installation Instructions visit [us.panasonic.com/ventfans](http://us.panasonic.com/ventfans)

Model	Quantity	Comments	Project:
			Location:
			Architect:
			Engineer:
			Contractor:
			Submitted by:
			Date:

**Panasonic Eco Solutions North America**  
**Eco Products Division**  
Two Riverfront Plaza  
Newark, NJ 07102

[us.panasonic.com/ventfans](http://us.panasonic.com/ventfans)

