

1. Gas Test Gauge
2. Water Test Gauge

Description & Features:

- Economical pressure gauge and valve body assembly used for pressure testing
- Bleed port and plated housing on the gas test assembly
- Swivel hose adaptor on the Water Test Gauge
- Black steel case
- Dual scale (PSI/kPa)
- ±3-2-3% accuracy
- CRN registered
- 5 year warranty

Applications:

- Residential & commercial pressure testing of natural gas, air and water lines

Specifications

Dial	2" (50 mm), 2.5" (63 mm) white aluminum with black and red markings
Case	Steel painted black
Lens	Polycarbonate
Ring	Steel, painted black
Bourdon Tube	Phosphor bronze
Movement	Brass
Pointer	Aluminum, black
Connection	Gas Test Gauge: 3/4" FNPT Water Test Gauge: 3/4" female swivel hose connection
Maximum Pointer	Available on Water Test Gauge only
Welding	#50 tin solder
Ambient/Process Temperature	-40°F to 150 °F (-40°C to 65°C)
Gas Test	40°F to 150 °F (-40°C to 65°C)
Water Test	32°F to 150 °F (0°C to 65°C)
Working Pressure	Maximum 75% of full scale value
Accuracy	±3-2-3% ANSI/ASME Grade B
Enclosure Rating	IP52

Order Codes (products in bold are normally in stock)

Product	Gas Test Gauge	Water Test Gauge	Maximum Pointer Water Test Gauge
Dial Size	2" (50mm)	2.5" (63mm)	2.5" (63mm)
Connection	Adapts to 3/4" FNPT	3/4" Female Swivel Hose Connection	3/4" Female Swivel Hose Connection
0/15 psi/kPa	PETG201	-	-
0/30 psi/kPa	PETG202	-	-
0/60 psi/kPa	PETG203	-	-
0/100 psi/kPa	PETG204	-	-
0/160 psi/kPa	-	PETW213	PETM213
0/300 psi/kPa	-	PETW217	PETM217

Other ranges and connection sizes available upon request. For scale change, refer to How to Order Guide for scale codes.

PET Economy Test Gauge

2" Gas Test Gauge

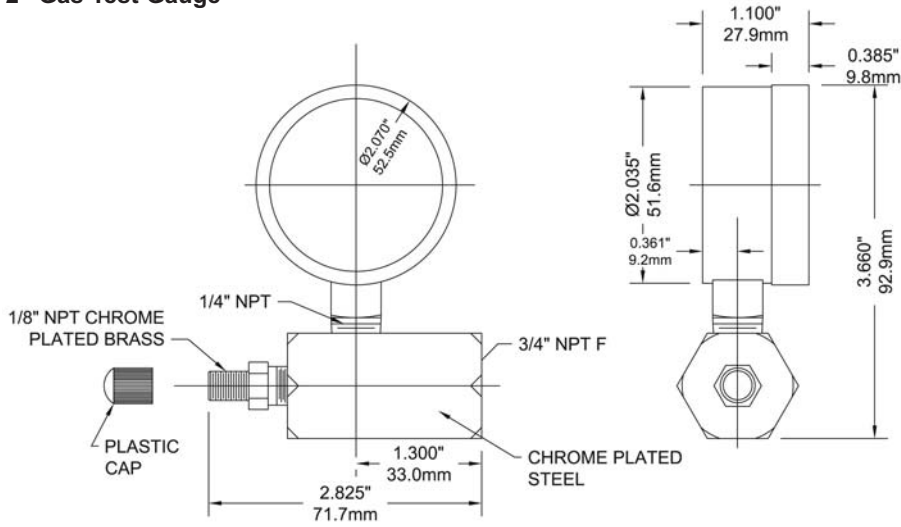

2.5" Water Test Gauge

