



See reverse for
min/max field adjustment

The Macon MTW thermostatic operator will help you balance your heating system. The MTW operator has one of the most accurate sensors for individual radiator temperature control. The problem of over-heating, under-heating and wide temperature swings can now be controlled.

The MTW thermostatic operator by Macon Controls conserves energy by regulating temperature. Fuel costs can be reduced up to 30%!

The MTW is a self-acting adjustable non-electric thermostatic operator. It has anti-freeze position, adjustable max./min. temperature, selected temperature locking feature and can be shutoff completely if required. Each MTW thermostatic operator is individually calibrated and conforms to ASHRAE standardization rules for temperature regulation. The MTW's smooth shape and narrow air gaps gives a nice operation and makes it easy to keep clean. Can be mounted on all Macon NT series valves. Millions are in use throughout the world.



MTW shown with
Macon NT series valve



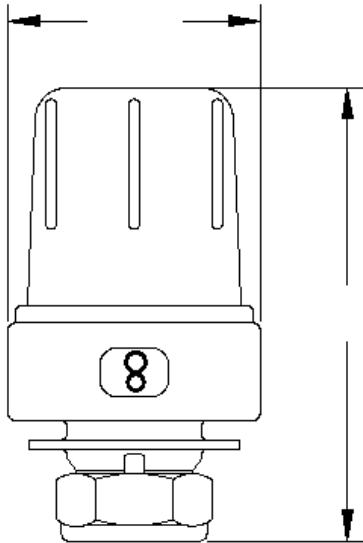

Maximum & Minimum Setting

Maximum setting

1. Turn the wheel to maximum and a red mark will occur in the indicating window (located opposite the dial setting window).
2. Push the mark in while turning the wheel to desired temperature according to below chart.
3. When reached desired temperature let go of the mark and the maximum temperature limit is set.

Minimum setting

1. Turn the wheel to minimum and a blue mark will occur in the indicating window (located opposite the dial setting window).
2. Push the mark in while turning the wheel to desired temperature according to below chart.
3. When reached desired temperature let go of the mark and the minimum temperature limit is set.

DATA

Temp. Range: 46° - 82°F
 Hysteresis: 0.9°F
 Heat Transfer: 1.1°F (Valve Housing Sensor)
 Dead Time: 0.8 Minutes
 Max. Differential Pressure: 20 psi
 Suggested Differential Pressure = 0.5 to 2.9 psi
 Max. Water Temp.: 250°F
 Max. Storage & Ambient Temp.: 122°F
 Max. Steam Pressure: 15 psig
 Max. Movement: 0.125
 Nominal Opening: 0.018 (3.6°F)
 Long Term Test: 5000 cycles (1.3°F)

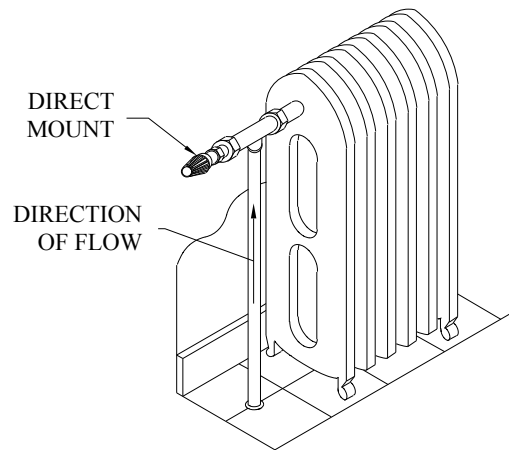

DIAL SETTINGS:

- 0 = Off
- * = 46°F (Frost Protection)
- 1 = 54°F
- 3 = 61°F
- 5 = 68°F
- 6 = 72°F
- 7 = 76°F
- 8 = 80°F
- 9 = 82°F

