

Job Name : \_\_\_\_\_  
 Purchaser : \_\_\_\_\_  
 Engineer : \_\_\_\_\_  
 Submitted To : \_\_\_\_\_  
 Submitted By : \_\_\_\_\_  
 Unit Designation : Schedule No.: \_\_\_\_\_

Location : \_\_\_\_\_  
 P.O. No. : \_\_\_\_\_  
 Architect : \_\_\_\_\_  
 Date : \_\_\_\_\_  
 For :  Reference  Approval  Construction  
 Model No.: \_\_\_\_\_

**Submittal Data : LS360HV** **Standard Single Zone Mini-Split**



**System Model #**

Indoor Model # LSN360HV  
 Outdoor Model # LSU360HV

**Performance :**

Capacity (Cooling)	33,100
(Heating)	35,200
EER	8.2
SEER	16.1
HSPF	9.9
Air Circulation (CFM H/M/L)	740/670/450
Fan Speeds	4/Auto/Chaos
Dehumidification (pts/hr)	10.6
Sound Data - Indoor (±3dB(A))	49/44/39
Sound Data - Outdoor (±3dB(A))	55
Cooling Indoor Air Temp Min/Max (°F DB)	64/90
Heating Indoor Air Temp Min/Max (°F DB)	61/86

**Electrical :**

Rated Voltage Outdoor (V, Hz, Ph)	230/208 , 60, 1
Rated Voltage Indoor (V, Hz, Ph)	230/208 , 60, 1
Minimum Circuit Ampacity (A)	16.8
Maximum Overcurrent Protection (A)	25
Cooling Running Current (Rated) (A)	17.8
Heating Running Current (Rated) (A)	17.8
Compressor Running Current (Rated) (A)	12.5
Fan Motor Running Current (Rated) (A)	0.6

**Dimensions :**

Indoor Dimension (WxHxD, inches)	47 5/8 x 13 5/8 x 8 1/16
Indoor Weight (lbs)	39.7
Outdoor Dimension (WxHxD, inches)	34 5/16 x 31 1/2 x 12 5/8
Outdoor Weight (lbs)	132.3

**Refrigerant Piping :**

Refrigerant Type	R410a
Refrigerant Charge (25ft)(lbs)	4.41
Liquid Side (inches, O.D)	3/8
Suction Side (inches, O.D)	5/8
Additional Refrigerant (oz./ft.)	0.38
Maximum Pipe Length (ft)	98
Piping length (no add'l refrigerant, ft.)	25
Maximum Elevation (ft)	49

**Standard Features :**

- Limited Five Year Compressor Warranty
- Limited Two Year Functional Parts Warranty
- Inverter (Variable Speed Compressor)
- Plasma Air Purifying System
- Chaos Swing Air Circulation
- Jet Cool™
- Temperature display on indoor unit
- Auto Restart
- Gold Fin™ Anti-Corrosion
- Built-in Low Ambient Standard down to 14°F (cooling mode)

**Note :**

**LSN360HV**

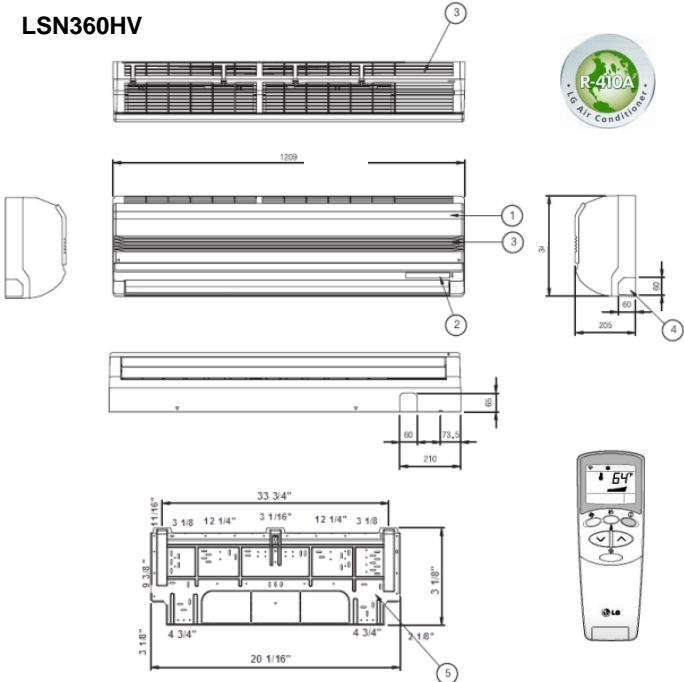

**LSU360HV**

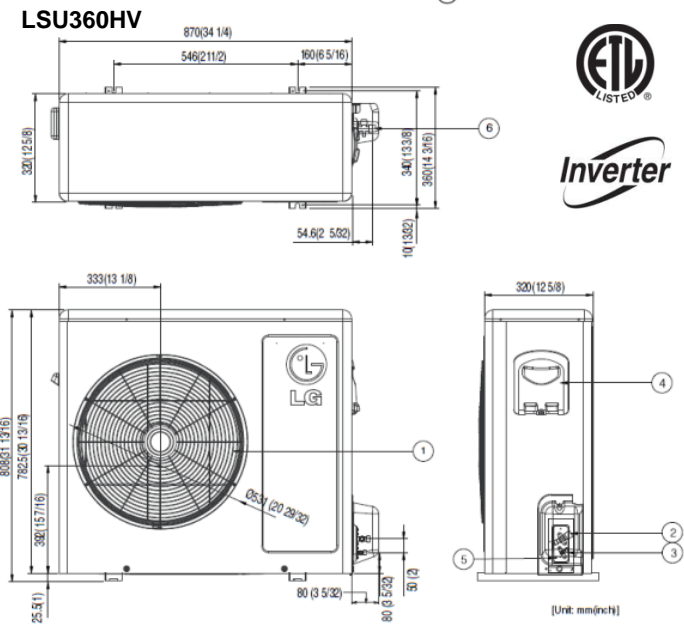

**Operating Range (Outdoor) :**

Cooling (°F)	14-115
Heating (°F)	5-75

**Accessory Option :**

- Wired Wall Thermostat – PQRVSL0(QW)