

Date:

For: File Resubmit
 Approval Other _____

PO No.:

Architect: _____ GC: _____

Engr: _____ Mech: _____

Rep: _____
 (Company) _____ (Project Manager)

LMVN240HV
 Multi F Vertical/Horizontal Air Handling Unit
 24,000 Btu/h Indoor Unit



Performance:

Nominal Capacity (Btu/h)	24,000
Cooling Nominal Test Conditions:	Heating Nominal Test Conditions:
Indoor: 80°F DB/67°F WB	Indoor: 70°F DB/60°F WB
Outdoor: 95°F DB/75°F WB	Outdoor: 47°F DB/43°F WB

Electrical:

Power Supply (V ¹ /Hz/Ø)	208-230/60/1
Rated Amps (A)	0.59

Piping:

Liquid Line (in, OD)	1/4
Vapor Line (in, OD)	1/2
Drain OD, ID (in)	3/4 FPT
Temperature Sensor	Thermistor

Features:

- ESP control
- Hot start
- Auto restart
- Child lock
- Inverter (variable speed fan)
- Group control
- Sleep mode
- Timer (on/off)

Optional Accessories (sold separately)

- LG Programmable Controller - PREMTB10U
- Wireless Handheld Remote Controller² - PQWRHDF0
- AC Smart II - PQCSW320A1E
- ACP without Digital I/O - PQCPA11A03
- ACP with Digital I/O - PQCPB11A0E
- LonWorks Gateway - PQNFB16A1
- BACnet Gateway - PQNFB17B0
- AC Ez - PQCSZ250S0
- Dry Contact Unit Dry Contact Unit (1 contact, 24 VAC external power) - PQDSB1
- Dry Contact Unit Dry Contact Unit (2 input, power from indoor unit) - PQDSBC
- Dry Contact for third party thermostat - PQDSBNGCM1
- Remote Temperature Sensor - PQRSTA0
- 5 kW Electric Heater - ANEH053B1
- 10 kW Electric Heater - ANEH103B2

Operating Range:

Cooling Max (°F WB)	76
Heating Min (°F DB)	59

Unit Data:

Refrigerant Type	R410A
Refrigerant Control	EEV
Sound Pressure ³ H/M/L (±3 dB(A))	43/42/41
Net Unit Weight (lbs)	117
Shipping Weight (lbs)	130

Fan:

Type	Sirocco
Quantity	1
Motor/Drive	Brushless Digitally Controlled/Direct
Airflow Rate H/M/L (CFM)	710/640/480
External Static Pressure ⁴ (in wg)	0.5

Standard Features:

- Access Panel for Field Supplied Air Filter
 - (16 x 20 x 1 inch)

Notes:

1. Acceptable operating voltage: 187V-253V.
2. Requires an LG Programmable Thermostat.
3. Sound Pressure levels are tested in an anechoic chamber under ISO Standard 1996.
4. Adjust fan speed to correct for static pressure increases when using field supplied air filter or heat kit.
5. See Engineering Manual for sensible and latent capacities.
6. All power/communication cable to be minimum 18 AWG, 4-conductor, stranded, shielded and must comply with applicable local and national code.
7. Power wiring cable size must comply with the applicable local and national codes.
8. This unit comes with a dry helium charge.
9. Corresponding refrigerant piping length is in accordance with standard length of each outdoor unit and the level difference is 0 ft. All capacities are net with a combination ratio between 95 – 105%.
10. Must follow installation instructions in the applicable LG installation manual.



Job Name/Location:

LMVN240HV
 Multi F Vertical/Horizontal Air Handling Unit
 24,000 Btu/h Indoor Unit



Tag #: _____
 Date: _____
 PO No.: _____

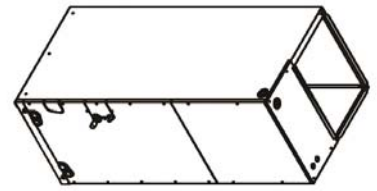
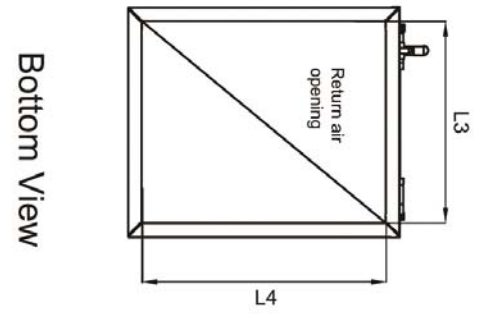
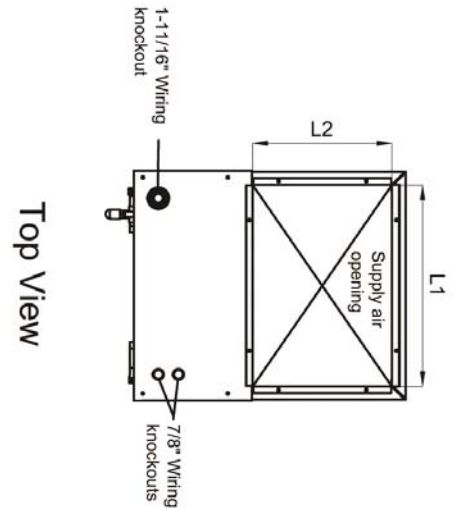
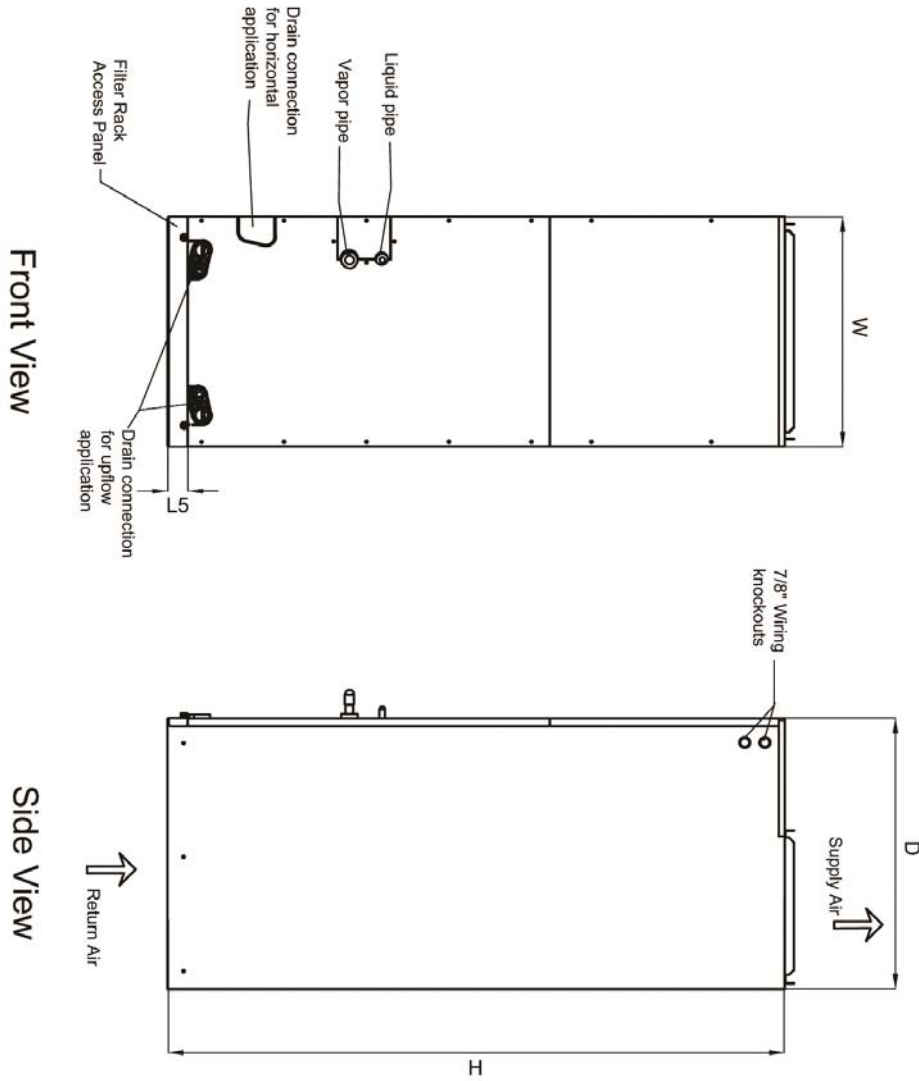

W	18"
D	21 1/4"
H	48 5/8"
L1	17"
L2	12 1/8"
L3	17 1/2"
L4	20"
L5	1 9/16"