



F261 Series Flow Switches

Installation Instructions

Part No. 24-7664-2969, Rev. D
Issued March 2016

Refer to the [QuickLIT website](#) for the most up-to-date version of this document.

Applications

IMPORTANT: Do not install or use this F261 Series Flow Switch in or near environments where corrosive substances or vapors could be present. Exposure of the F261 Series Flow Switch to corrosive environments may damage the device's internal components and will void the warranty.

IMPORTANT: Do not use F261 Series Flow Switches where the fluid in the pipes drops below the fluid's freezing point, causing an internal freeze-up.

IMPORTANT: Use this F261 Series Flow Switch only as an operating control. Where failure or malfunction of the flow switch could lead to personal injury or property damage to the controlled equipment or other property, additional precautions must be designed into the control system. Incorporate and maintain other devices, such as supervisory or alarm systems or safety or limit controls, intended to warn of or protect against failure or malfunction of the flow switch.

IMPORTANT : Utiliser ce F261 Series Flow Switch uniquement en tant que dispositif de régulation. Lorsqu'une défaillance ou un dysfonctionnement du flow switch risque de provoquer des blessures ou d'endommager l'équipement contrôlé ou un autre équipement, la conception du système de contrôle doit intégrer des dispositifs de protection supplémentaires. Veiller dans ce cas à intégrer de façon permanente d'autres dispositifs, tels que des systèmes de supervision ou d'alarme, ou des dispositifs de sécurité ou de limitation, ayant une fonction d'avertissement ou de protection en cas de défaillance ou de dysfonctionnement du flow switch.

The F261 Series Flow Switches respond to fluid flow in lines carrying water, ethylene glycol, or other nonhazardous fluids. These models also work in applications with swimming pool water and lubricating oils.

F261 Series Standard Flow Switches use a variety of paddle sizes to respond to fluid flow rates in applications with 1 inch trade size (or greater) pipe.

F261 Series Low Flow Switches respond to low fluid flow rates in applications with 1 inch trade size (or less) pipe.

A low-energy model with gold-plated contacts provides improved electrical performance in low-voltage, low-current circuits to operate small relays, solenoid valves, and electronic control circuits.

Installation

F261 Series Standard Flow Switches are packaged with 1 in., 2 in., 3 in., and 6 in. stainless steel flow paddles along with a paddle screw and lock washer. See Table 2 for replacement parts.

Dimensions

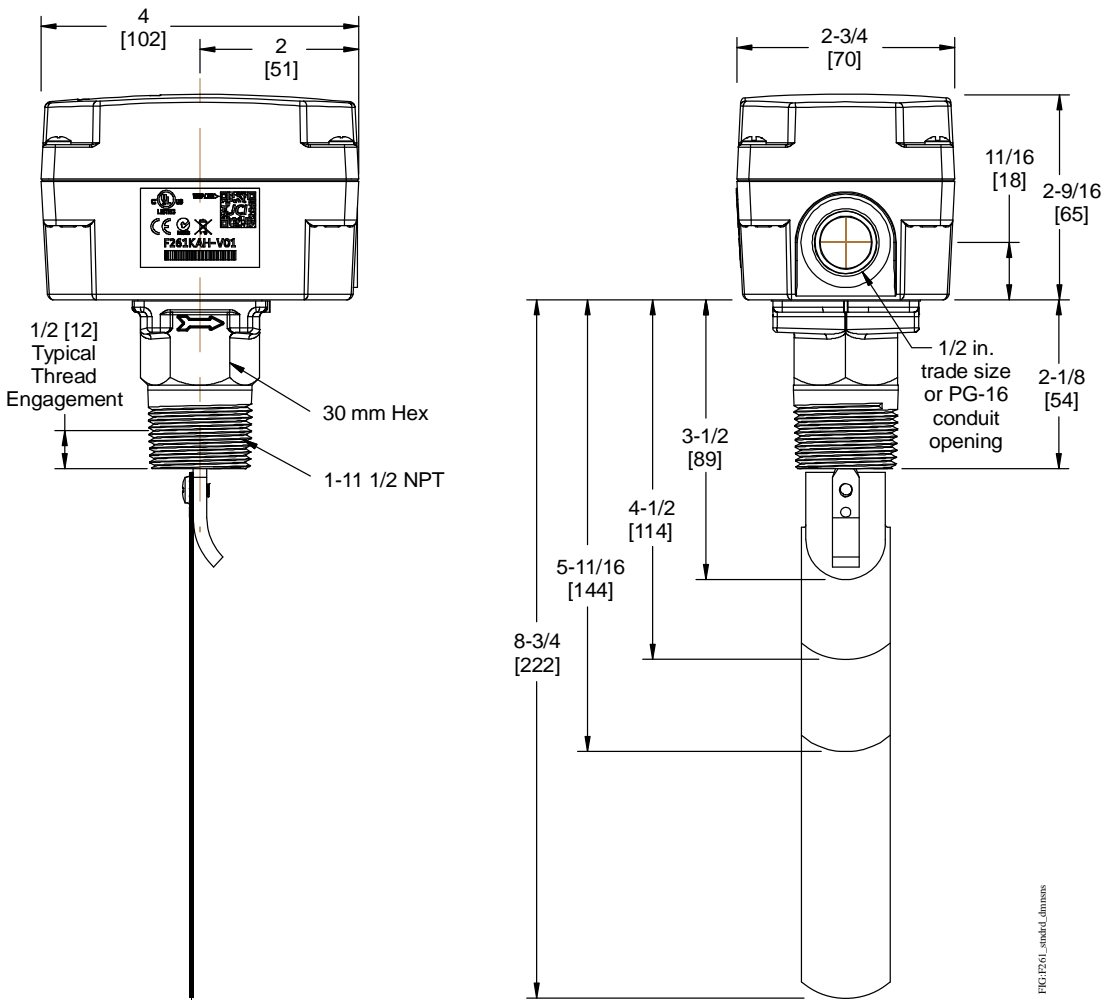

Figure 1: Dimensions for F261 Standard Flow Switch, in. [mm]

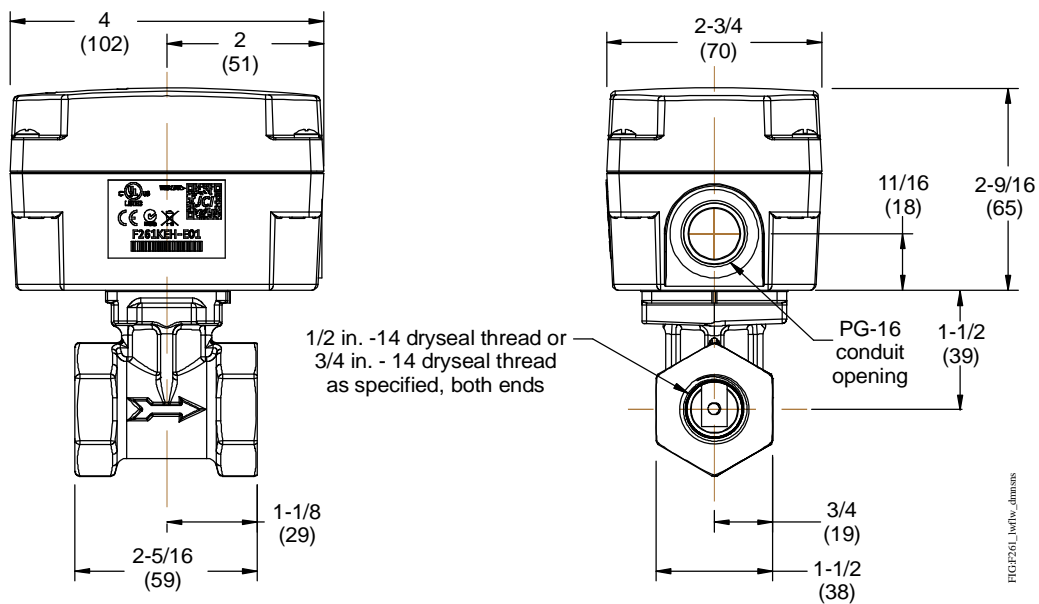

Figure 2: Dimensions for F261 Low-Flow Switch, in. [mm]

Installing the Flow Paddles



WARNING: Risk of Personal Injury.

Shut off the liquid supply and relieve pressure in the line before servicing the valve. Contents of liquid lines could be under pressure and the release of liquid under pressure may cause severe personal injury.

AVERTISSEMENT : Risque de blessure.

Couper l'arrivée de liquide et évacuer la pression présente dans la conduite avant toute intervention sur la vanne. Les liquides à l'intérieur des conduites peuvent être sous pression et la libération soudaine de liquide sous pression risque de provoquer des blessures graves.

IMPORTANT: The flow paddle must not touch the pipe or any restrictions in the pipe. If the flow paddle touches the pipe (or restrictions in the pipe), the switch may not be able to properly detect changes in fluid flow.

Adjust the flow paddles to the size of the pipe used. Install the large flow paddle, if needed. Trim the flow paddle at the arc corresponding to the pipe size. See Figure 3, Figure 4, Figure 5, and Table 1.

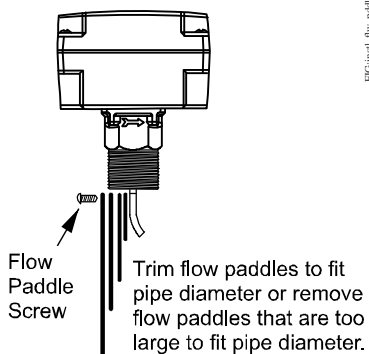

Figure 3: Installing the Flow Paddles

Note: Allow a minimum clearance of 3/16 in. (5 mm) between the end of the flow paddle and the pipe wall.

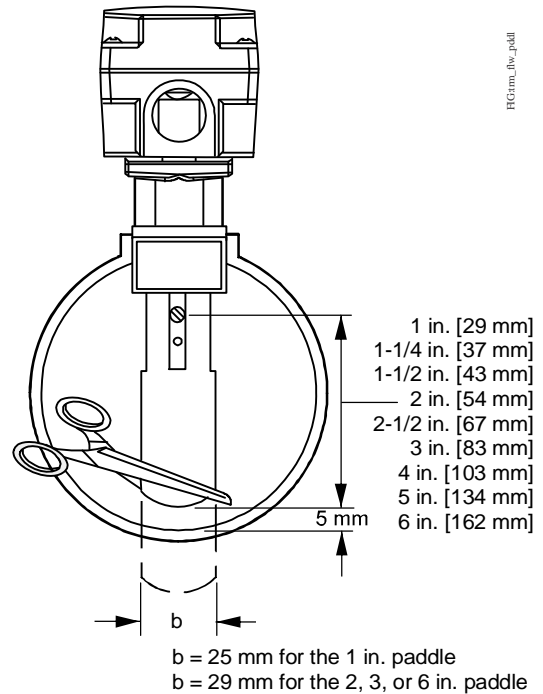

Figure 4: Trimming the Flow Paddles

Table 1: Trimming the Flow Paddles

Paddle Size	Use or Trim This Paddle to Fit
1 in.	1 in.
1-1/4 in.	2 in.
1-1/2 in.	2 in.
2 in.	2 in.
2-1/2 in.	3 in.
3 in.	3 in.
4 in.	6 in.
5 in.	6 in.
6 in.	6 in.

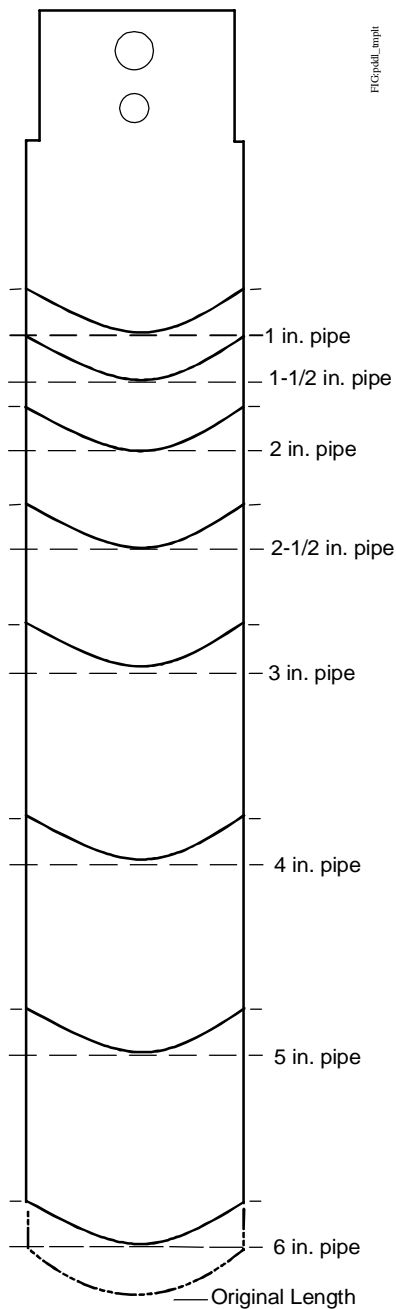

Figure 5: Trimming Diagram for the Large Flow Paddle

Accessories

Table 2: Replacement Paddle Parts

Product Code Number	Description
KIT21A-600	Stainless steel 3-piece paddle (3 in., 2 in., and 1 in. segments)
KIT21A-601	Stainless steel 6 in. paddle
PLT52A-600R	Stainless steel 3-piece paddle (3 in., 2 in., and 1 in. segments) and Stainless steel 6 in. paddle

Mounting

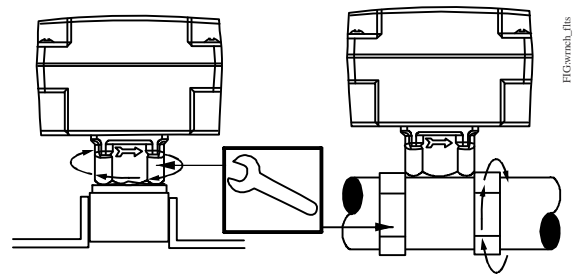

Figure 6: Use Only the Wrench Flats Provided

IMPORTANT: To avoid damaging the switch, do not tighten the switch to the tee by grasping the switch enclosure. Use only the wrench flats provided.

Mount the F261 Series Flow Switches using the following guidelines:

- Install the switch so that the enclosure and interior are accessible.
- Mount the switch so that the flow of the fluid is in the direction of the arrow on the enclosure.
- Use a pipe union on each side of the flow switch to allow for easy removal or replacement.
- Do not allow the pipe to extend too far into the flow switch casing.
- Use pipe thread sealer or teflon tape on the male threads only.
- Do not remove the case-to-cover O-ring on Type 4/IP67 enclosures.

For standard 1 in. x 1 in. pipe installation, mount the F61 flow switch in a standard 1 in. x 1 in. x 1 in. tee. For larger sizes of pipe, use a reducing tee to keep the flow switch close to the pipe and provide adequate paddle length in the flow stream.

Example: Use a 2 in. x 2 in. x 1 in. tee for a 2 in. pipe. If a standard 2 in. x 2 in. x 2 in. tee is used, install a face or hex bushing in the top opening to reduce the top opening to 1 in.

Location Considerations

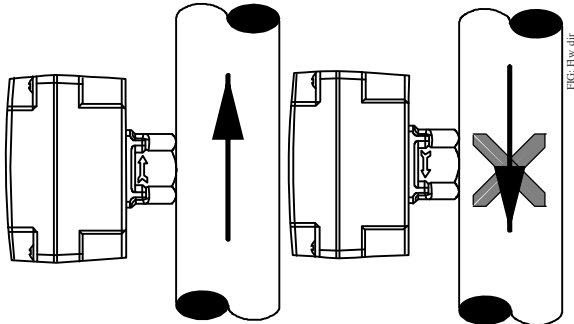

Figure 7: Flow Direction for Vertical Mounting

IMPORTANT: Do not use in a vertical pipeline with a downward flow.

Mount the F261 flow switch in a horizontal pipeline or a vertical pipeline with upward fluid flow. When mounted in a vertical pipe with an upward flow, the switch trips at a slightly higher flow than shown in Table 4 and Table 5, due to the effect of gravity on the switch mechanism.

Mount the F261 flow switch in a section of pipe where there is a straight run of at least five pipe diameters from the nearest elbow, valve, or other pipe restriction. See Figure 8.

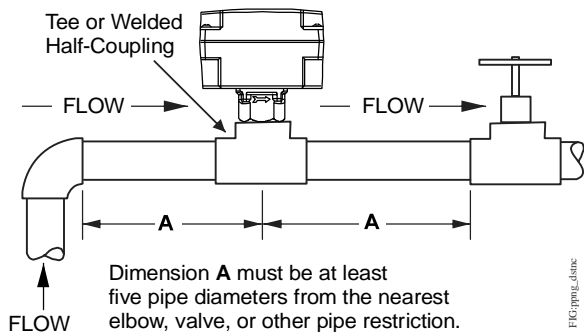

Figure 8: Required Piping Distance

When mounting the flow switch on horizontal pipe, mount the flow switch within 60 degrees of vertical. See Figure 9.

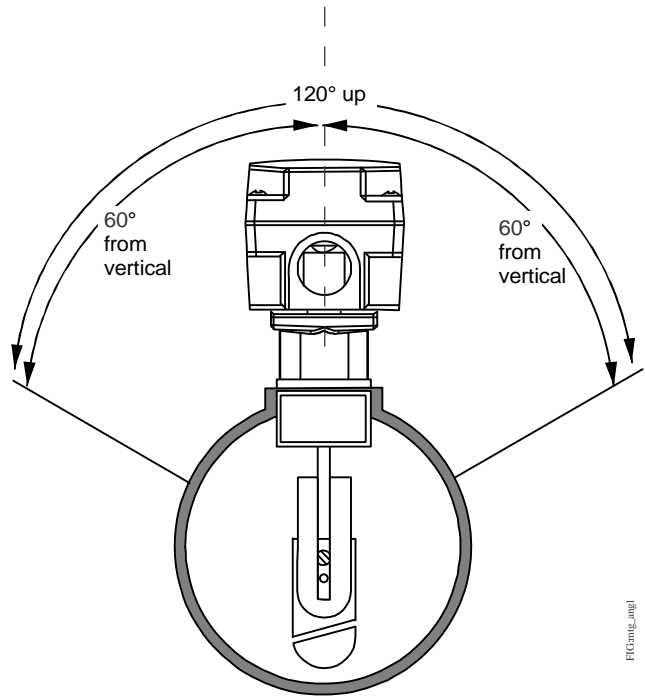

Figure 9: Angle Allowed

Note: Do not subject the flow switches to water hammer. Use a suitable water hammer arrester if a fast-closing valve is located downstream of the switch. See Figure 10.

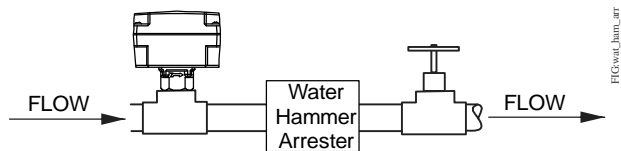

Figure 10: Water Hammer Arrester Location

Wiring



WARNING: Risk of Electric Shock.

Disconnect the power supply before making electrical connections. The printed circuit board and its components are at AC line voltage. Contact with components carrying hazardous voltage can cause electric shock and may result in personal injury or death.

AVERTISSEMENT : Risque de décharge électrique.

Débrancher l'alimentation avant de réaliser tout raccordement électrique. Le circuit imprimé et ses composants présentent une tension CA. Tout contact avec des composants porteurs de tensions dangereuses risque d'entraîner une décharge électrique et de provoquer des blessures graves, voire mortelles.

IMPORTANT: Use the terminal screws provided (M4 x 8 crosshead). Substitution of other screws voids the warranty and agency approvals.

IMPORTANT: To prevent moisture from entering and condensate from forming inside the Type 3R/IP43 enclosure, **do not** block the drain hole provided.

To prevent moisture from entering and condensate from forming inside the Type 4/IP67 enclosure, **do not** remove the case-to-cover O-ring provided on the flow switch.

IMPORTANT: Use copper conductors only. Make all wiring in accordance with local, national, and regional regulations.

IMPORTANT: Do not exceed the control's electrical ratings. Exceeding the control's electrical ratings can result in permanent damage to the control and void any warranty.

The F261 models have three color-coded terminals. Red is common. See Figure 11 and Table 3 for switch action.

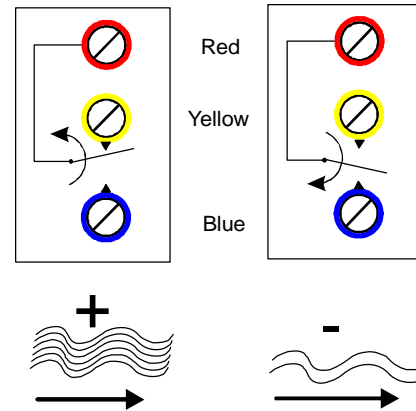

Figure 11: F261 Control Switch Action

Table 3: F261 Control Switch Action

Flow Action	Switch Closure
Increase	Red to Yellow
Decrease	Red to Blue

Setup and Adjustments



CAUTION: Risk of Property Damage.

Do not set the switch lower than the factory setting. The switch is factory set at approximately the minimum flow rate. A lower setting may result in the switch failing to return to a no-flow position which may result in damage to the controlled equipment or other property.

MISE EN GARDE : Risque de dégâts matériels.

Ne pas régler le commutateur sur une valeur inférieure au paramètre d'usine. Le commutateur est réglé en usine sur une valeur correspondant environ au débit minimum. Un réglage sur une valeur inférieure risque d'empêcher le commutateur de revenir sur une position « aucun-débit », ce qui risque d'endommager l'équipement contrôlé ou de provoquer d'autres dégâts matériels.



CAUTION: Risk of Property Damage.

Do not attempt to change sealed settings. Attempted adjustment may damage the control or cause loss of calibration or other property damage.

MISE EN GARDE : Risque de dégâts matériels.

Ne pas essayer de modifier la position des éléments de réglage bloqués. Toute tentative de réglage risque d'endommager le dispositif de contrôle ou de provoquer la perte des valeurs d'étalonnage ou d'autres dégâts matériels.

To adjust the setting of the flow switch:

1. Disconnect the power supply before making any electrical connections.
2. Remove the enclosure cover.
3. Adjust the control's flow rate (Figure 12):
 - Turn the adjustment screw **clockwise** to **raise** the flow rate required to activate the switch.
 - Turn the adjustment screw **counterclockwise** to **lower** the flow rate required to activate the switch.

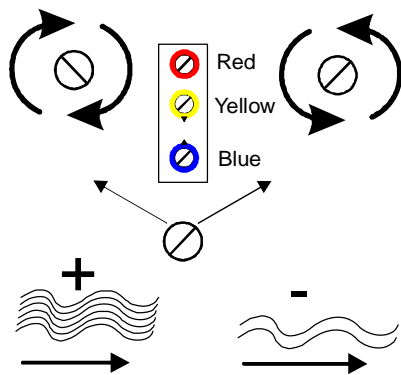

Figure 12: Flow Rate Adjustment

Note: Do not lower the flow rate required to activate the switch, unless the flow rate required to activate the switch was raised from the factory-set flow rate.

4. Replace the enclosure cover and tighten the cover screws with 12 in•lb of torque.

To verify that the flow rate is set above the factory minimum, depress the main lever (see Figure 13) multiple times:

- if the lever clicks every time when returning to the original position, then the control's flow rate may be set at or above the factory-set minimum value.
- if the lever fails to click every time when returning to the original position, then the control's flow rate is set below the factory-set minimum value.

Turn the adjustment screw **clockwise** to **raise** the flow rate required to activate the switch. See Figure 12.

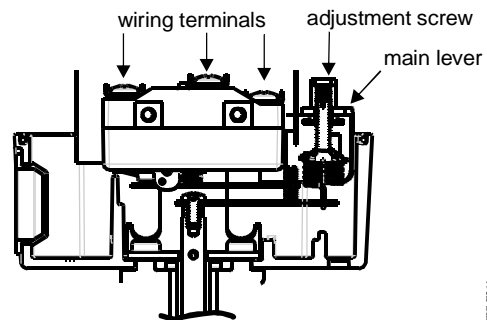

Figure 13: Minimum Adjustment

FIG1261_C001_v1.0

Table 4: Flow Rates for Standard Models, 1-3 in. Paddles, GPM (m³/hr)

		GPM (m ³ /hr) Required to Activate Switch for Pipe Size (in.)									
		1	1-1/4 ¹	1-1/2 ¹	2	2-1/2 ²	3	4 ³	5 ³	6 ³	8 ³
Minimum Adjustment	Flow Increase (Close R to Y)	4.20 (0.95)	5.80 (1.32)	7.50 (1.70)	13.7 (3.11)	18.0 (4.09)	27.5 (6.24)	65.0 (14.8)	125 (28.4)	190 (43.2)	375 (85.2)
	Flow Decrease (Close R to B)	2.50 (0.57)	3.70 (0.84)	5.00 (1.14)	9.50 (2.16)	12.5 (2.84)	19.0 (4.32)	50.0 (11.4)	101 (22.9)	158 (35.9)	320 (72.7)
Maximum Adjustment	Flow Increase (Close R to Y)	8.80 (2.0)	13.3 (3.02)	19.2 (4.36)	29.0 (6.59)	34.5 (7.84)	53.0 (12.0)	128 (29.1)	245 (55.6)	375 (85.2)	760 (173)
	Flow Decrease (Close R to B)	8.50 (1.93)	12.5 (2.84)	18.0 (4.09)	27.0 (6.13)	32.0 (7.27)	50.0 (11.4)	122 (27.7)	235 (53.4)	360 (81.8)	730 (166)

1. Values for 2 in. paddle trimmed to pipe.
2. Values for a 3 in. paddle trimmed to fit pipe.
3. Values calculated for a factory-installed set of 1, 2, and 3 in. paddles.

Table 5: Flow Rates for Standard Models, 6 in. Paddles, GPM (m³/hr)

		GPM (m ³ /hr) Required to Activate Switch for Pipe Size (in.)			
		4	5	6	8
Minimum Adjustment	Flow Increase (Close R to Y)	37.0 (8.40)	57.0 (12.9)	74.0 (16.8)	205 (46.6)
	Flow Decrease (Close R to B)	27.0 (6.13)	41.0 (9.31)	54.0 (12.3)	170 (38.6)
Maximum Adjustment	Flow Increase (Close R to Y)	81.0 (18.4)	118 (26.8)	144 (32.7)	415 (94.3)
	Flow Decrease (Close R to B)	76.0 (1.93)	111 (25.2)	135 (30.7)	400 (90.8)

Table 6: GPM (L/Min) Required to Actuate F261 Series Low Flow Switches

		Pipe Size		
		1/2 x 1/2 in. Female NPTF ¹	3/4 x 3/4 in. Female NPTF ²	3/4 x 3/4 in. Female NPTF ³
Minimum Adjustment	Flow Increase (R to Y Closes)	1.30 (4.92)	2.00 (7.57)	10.90 (41.26)
	Flow Decrease (R to B Closes)	0.60 (2.27)	0.60 (2.27)	7.20 (27.25)
Maximum Adjustment	Flow Increase (R to Y Closes)	2.60 (9.84)	3.60 (13.63)	17.00 (64.35)
	Flow Decrease (R to B Closes)	1.25 (4.73)	1.30 (4.92)	14.20 (53.75)

1. F261KEH-V01C, F261MEH-V01C
2. F261KFH-V01C, F261MFH-V01C
3. F261KFH-V02C (designed for steam applications)

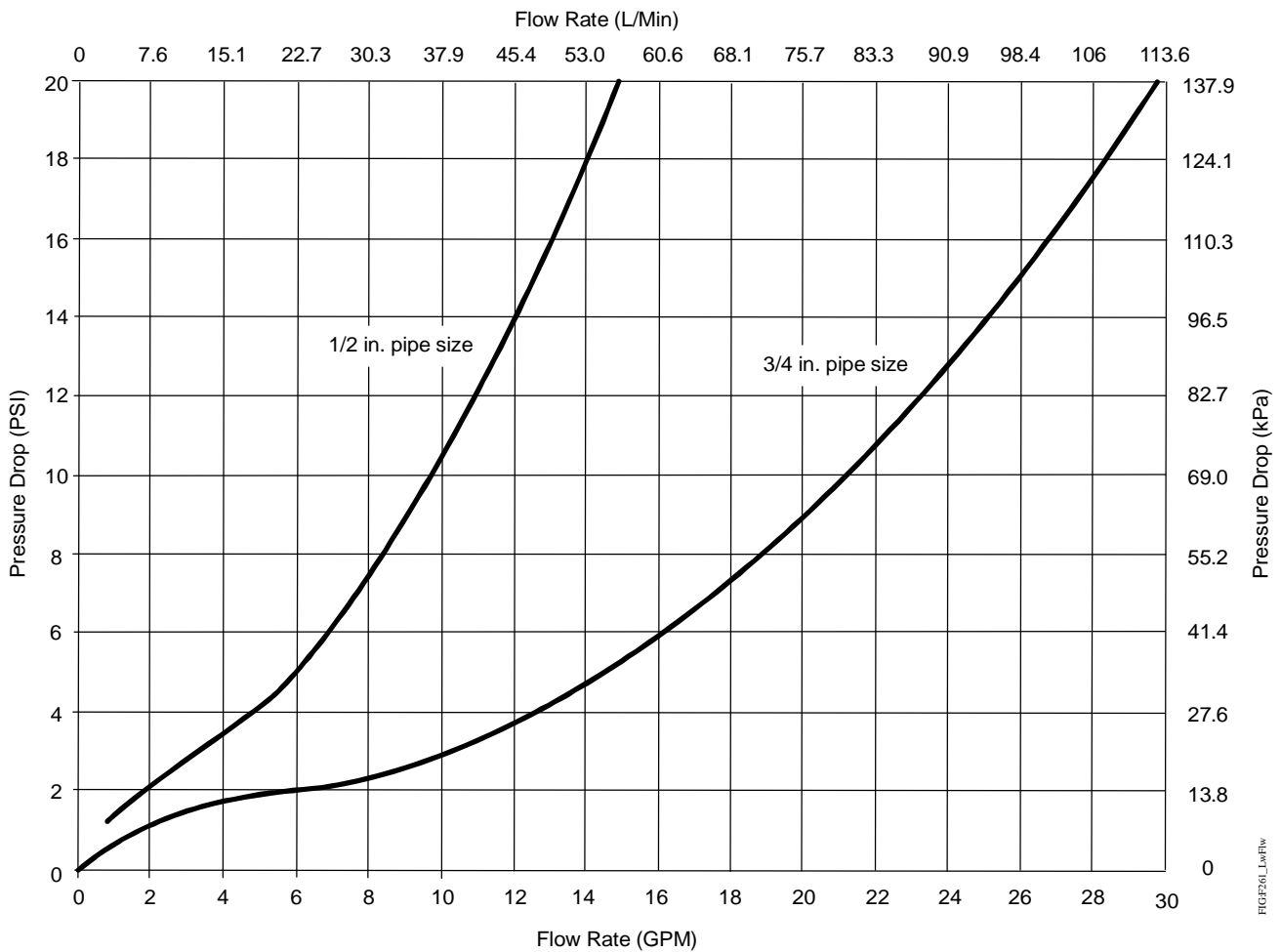

Figure 14: Pressure Drop versus Flow Rate, F261 Series Low-Flow Switches (F261KEH-V01C, F261MEH-V01C, F261KFH-V01C, F261MFH-V01C)

Operation

The flow switch responds to pressure exerted on the fluid paddle by the flowing fluid. A range adjustment screw adjusts the rate of the flow required to activate the switch. For flow rates, see Table 4 through Table 6. For pressure drop versus flow rate, see Figure 14.

The red terminal is the Common. Red to Yellow closes on flow increase. Red to Blue closes on flow decrease.

Table 7: F261 Control Switch Action

Flow Action	Switch Closure
Increase	Red to Yellow
Decrease	Red to Blue

Checkout Procedure

Ensure that installation, wiring, and control settings are according to the application requirements. Refer to the controlled system's manufacturer specifications for the proper settings when adjusting these controls.

Apply power to the control and controlled equipment. Cycle the controlled system at least three times at normal operating conditions.

Repair Information

Do not make field repairs, except for replacement of the flow paddle. For a replacement control or paddle kit, contact the nearest Johnson Controls/PENN distributor. For more information, contact Johnson Controls/PENN application engineering at 1-800-275-5676.

Troubleshooting

Table 8: Troubleshooting

Symptom	Solution
Water (condensate) appears within the enclosure.	If the control has a Type 3R/IP43 enclosure, inspect the grommet in the field-installed cable gland or conduit fitting, and replace the grommet if it is defective. If the control has a Type 4/IP67 enclosure, inspect the case-to-cover O-ring provided on the flow switch. Ensure that the O-ring is in place and undamaged. Ensure the control uses a correct cable gland or conduit fitting for Type 4/IP67 applications.
Fluid from the tank leaks into the enclosure due to a rod seal failure.	Replace the flow switch.
Switch does not activate due to debris in switch mechanism.	Clear any debris from within the switch mechanism. Test the operation of the switch several times for proper operation.
Control switch action is reversed.	Ensure connections follow wiring diagrams.
Control does not switch.	Check the electrical connections.
Switch fails to return to the no-flow position.	The switch may be set lower than the factory setting. Increase the setting. On vertical pipes, ensure that the direction of flow is up. The arrow on the switch enclosure must point in the direction of the flow.
Control does not switch on flow increase.	Check for a cracked or broken paddle. Replace the paddle, if necessary.

Technical Specifications

Table 9: F261xxH Series Standard Controls Electrical Ratings

Volts 50/60 Hz	UL60730/UL1059				EN60730	
	24	120	208	240	24	230
Horsepower	–	1	1	1	–	–
Full Load Amperes	–	16	10	10	–	8
Locked Rotor Amperes	–	96	60	60	–	48
Resistive Amperes	16	16	10	10	16	16
Pilot Duty VA	125	720	720	720	77	720

Table 10: F261xxL Series Low Energy Controls Electrical Ratings, AC Current

Volts AC, 50/60 Hz	UL60730/UL1059/EN60730		
	4 VAC	24 VAC	120 VAC
Resistive Amperes ¹	10	10	10
Pilot Duty VA ²	12	72	360

1. **Maximum Dry Circuit Rating:** Resistive only, 400 mW at 28 VAC/VDC.
Once a relay has been used at the General Rating level, the Dry Circuit Rating is no longer valid.
2. Meets UL 100,000 cycle UL endurance test requirement at switch with T_{min} greater than or equal to 32°F (0°C).

Table 11: F261xxL Series Low Energy Controls Electrical Ratings, DC Current

Volts DC	UL60730/UL1059/EN60730		
	4 VDC	24 VDC	48 VDC
Resistive Amperes ¹	1	1	1

1. **Maximum Dry Circuit Rating:** Resistive only, 400 mW at 28 VAC/VDC.
Once a relay has been used at the General Rating level, the Dry Circuit Rating is no longer valid.

Table 12: UL Conformity Declaration Information

Information	Description
Purpose of Control	F261 Fluid Flow Switch
Construction of Control	Electronic independently mounted control
Number of Cycles	100,000 cycles
Method of Mounting Control	Mounting to sensed media vessel/orientation
Type 1 or Type 2 Action	Type 1.C (Microinterruption)
External Pollution Situation	Pollution degree 4
Internal Pollution Situation	Pollution degree 2
Rated Impulse Voltage	4,000 VAC
Ball Pressure Temperature	Enclosure: 266°F (130°C) Switch Component: 252°F (122°C)
Control Adjustment Instruction	-
Field Wiring Rating	Wire/Cord Temperature Ratings: <ul style="list-style-type: none"> • 140°F (60°C) only permitted when ambient air and media are less than 113°F (45°C) • 167°F (75°C) only permitted when ambient air and media are less than 140°F (60°C) • 194°F (90°C) only permitted when ambient air is less than 140°F (60°C) and media is less than 167°F (75°C) • 302°F (150°C) permitted when ambient air is less than 140°F (60°C) and media is less than 249°F (121°C)
Vessel Pressure	F261 Fluid Flow Switch: 290 psi (20 Bar)

F261 Series Fluid Flow Switches

Switch	SPDT
Enclosure	UL: Type 3R or Type 4 CE: IP43 (IP23 with drain hole plug removed) or IP67
Wiring Connections	Three color-coded screw terminals and one ground terminal
Conduit Connection	One 7/8 in. (22 mm) hole for 1/2 in. trade size (or PG16) conduit
Pipe Connector	Standard: 1 in. 11-1/2 NPT Threads Low-Flow: 1/2 in. x 1/2 in. Female NPTF 3/4 in. x 3/4 in. Female NPTF
Maximum Fluid Pressure	290 psi (20 bar)
Minimum Fluid Temperature¹	-20°F (-29°C)
Maximum Fluid Temperature²	250°F (121°C)
Ambient Conditions	-40 to 140°F (-40 to 60°C)
Compliance	 <p>North America: cULus Listed; UL 60730, File E6688; FCC Compliant to CFR47, Part 15, Subpart B, Class B Industry Canada (IC) Compliant to Canadian ICES-003, Class B limits</p> <p>Europe: CE Mark – Johnson Controls, Inc. declares that this product is in compliance with the essential requirements and other relevant provisions of the EMC Directive and the Low Voltage Directive.</p> <p>Australia/New Zealand Mark: RCM Compliant</p>

1. Ensure that the low liquid temperature combined with the low ambient temperature does not lead to freezing the liquid inside the body (or bellows, where appropriate). Please observe the liquid freezing point.
2. At higher ambient temperatures, the maximum allowed liquid temperature becomes lower. The temperature of the electrical switch inside should not exceed 158°F (70°C).

The performance specifications are nominal and conform to acceptable industry standards. For application at conditions beyond these specifications, consult Johnson Controls/PENN Refrigeration Application Engineering at 1-800-275-5676. Johnson Controls, Inc. shall not be liable for damages resulting from misapplication or misuse of its products.

United States Emissions Compliance

This equipment has been tested and found to comply with the limits for a Class B digital device, pursuant to Part 15 of the FCC Rules. These limits are designed to provide reasonable protection against harmful interference in a residential installation. This equipment generates, uses and can radiate radio frequency energy and, if not installed and used in accordance with the instructions, may cause harmful interference to radio communications. However, there is no guarantee that interference will not occur in a particular installation. If this equipment does cause harmful interference to radio or television reception, which can be determined by turning the equipment off and on, the user is encouraged to try to correct the interference by one or more of the following measures:

- Reorient or relocate the receiving antenna.
- Increase the separation between the equipment and receiver.
- Connect the equipment into an outlet on a circuit different from that to which the receiver is connected.
- Consult the dealer or an experienced radio/TV technician for help.

Canadian Emissions Compliance

This Class (B) digital apparatus meets all the requirements of the Canadian Interference-Causing Equipment Regulations. Cet appareil numérique de la Classe (B) respecte toutes les exigences du Règlement sur le matériel brouilleur du Canada.

European Single Point of Contact:

JOHNSON CONTROLS
WESTENDHOF 3
45143 ESSEN
GERMANY

NA/SA Single Point of Contact:

JOHNSON CONTROLS
507 E MICHIGAN ST
MILWAUKEE WI 53202
USA

APAC Single Point of Contact:

JOHNSON CONTROLS
C/O CONTROLS PRODUCT MANAGEMENT
NO. 22 BLOCK D NEW DISTRICT
WUXI JIANGSU PROVINCE 214142
CHINA



Building Efficiency

507 E. Michigan Street, Milwaukee, WI 53202

© Johnson Controls and PENN are registered trademarks of Johnson Controls, Inc. in the United States of America and/or other countries. All other trademarks used herein are the property of their respective owners. © Copyright 2016 by Johnson Controls, Inc. All rights reserved.