



**SMARTSERIES™**  
by QMARK

**Outsmarts The Competition**

## Digital Programmable Wall Heater

- ▶ 5/2 DAY PROGRAMMABLE THERMOSTAT
- ▶ LED TOUCH SCREEN OPERATION WITH ADJUSTABLE SOUND
- ▶ AUTOMATIC ADJUSTABLE WATTAGE OUTPUT
- ▶ FAN ONLY MODE
- ▶ CONVENIENT REMOTE CONTROL INCLUDED
- ▶ 5 YEAR ELEMENT WARRANTY



### HEATER REMOTE

An easy to use remote control is included to provide convenient heat and power adjustment from up to 12 feet away. Heater must be in direct line of sight to operate correctly. Unit can be controlled with or without remote control.



### ▶ APPLICATIONS INCLUDE:

- DENS
- BASEMENTS
- BATHROOMS
- BEDROOMS
- OFFICES
- ... AND MUCH MORE



**OUTSMART** THE COMPETITION



**SMARTSERIES™**  
www.smartseriesheat.com

# OUTSMART THE COMPETITION

## SELECTION CHART

CATALOG NUMBER	VOLTS	AMPS	WATTS	BTUHR	WIRE SIZE
HT2024SS	240	1.0 - 8.3	250 - 2000	853 - 6826	14 AWG
HT1502SS	120	1.6 - 12.5	200 - 1500	682 - 5120	12 AWG

## THERMOSTAT DISPLAY

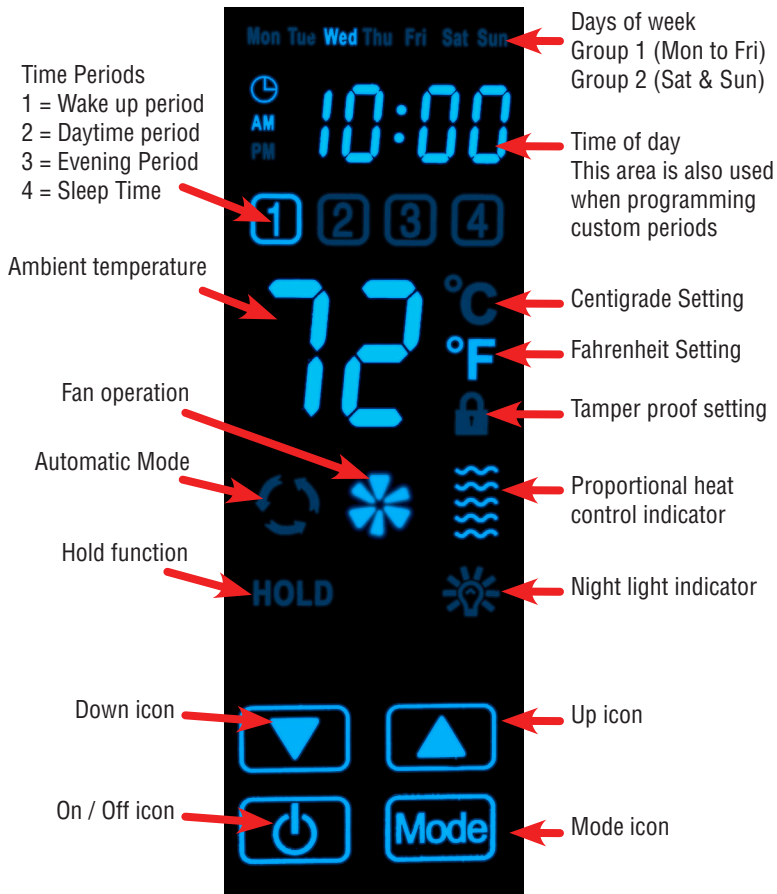

## FEATURES

- ▶ Heater automatically adjusts wattage output and blower speed resulting in whisper quiet operation for optimum comfort.
- ▶ Heating element is heavy duty non-glowing steel fins brazed to steel sheathed tubular elements in a grid pattern that covers the entire discharge area.
- ▶ Built-in fan delay operates when unit is turned off after heating to prolong element life.
- ▶ 5/2 day electronic programmable built-in thermostat adaptable to fit any life style while providing energy savings and precise temperature performance.
- ▶ Easy to use LED touch screen operation.
- ▶ Convenient remote control included.
- ▶ Contemporary, clean design with night light feature complements any decor.
- ▶ Designed for easy installation. Heater is mounted prior to wiring. Both hands are free to make field connections in roomy compartment.
- ▶ This heater is designed for installation in 2 x 4 frames or larger wall sections using the wall box provided.
- ▶ The heater may be wired with standard building wire (60°C). Refer to specification chart for correct supply voltage and wire size.

## DIMENSIONS

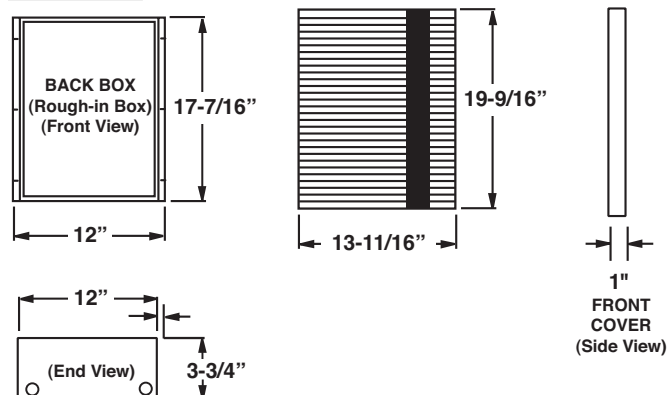

## MOUNTING LIMITATIONS

Do not install heater closer than 12" to the floor, 12" to an adjacent wall, 36" to the ceiling.

Do not install heater behind towel rack or door, upside down or sideways, in the floor, ceiling, or in closets.