

OIL-FIRED WATER HEATER

A Spanish language version of these instructions is available by contacting the manufacturer listed on the rating plate.

La version Espanola de estas instrucciones se puede obtener al escribirle a la fábrica cuyo nombre aparece in la placa de especificaciones.

INSTALLATION & OPERATING INSTRUCTION MANUAL

THE WARRANTY ON THIS WATER HEATER IS IN EFFECT ONLY WHEN THE WATER HEATER IS INSTALLED AND OPERATED IN ACCORDANCE WITH LOCAL CODES AND THESE INSTRUCTIONS. THE MANUFACTURER OF THIS HEATER WILL NOT BE LIABLE FOR ANY DAMAGE RESULTING FROM FAILURE TO COMPLY WITH THESE INSTRUCTIONS. READ THESE INSTRUCTIONS THOROUGHLY BEFORE STARTING.

For your family's comfort, safety and convenience, we recommend this water heater be installed and serviced by a plumbing professional.

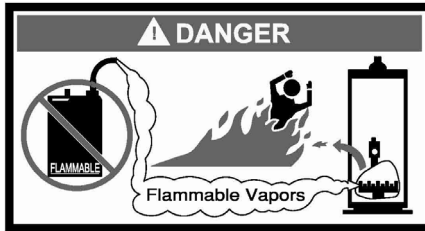

TABLE OF CONTENTS

General Information	3
Installation	3
Locating the water heater	3
Minimum clearances	4
Combustion air supply	6
Electrical connections.....	6
Venting.....	7
Water connections.....	8
Installation for potable water and space heating	11
Oil tanks and piping.....	12
Operation	15
Burner and thermostat information	16
Maintenance.....	23

CONGRATULATIONS!

You have just purchased one of the finest water heaters on the market today!

This installation, operation and instruction manual will explain in detail the installation and maintenance of your new Oil-Fired Water Heater. We strongly recommend that you contact a plumbing professional for the installation of this water heater.

We require that you carefully read this manual, as well as the enclosed warranty, and refer to it when questions arise. If you have any specific questions concerning your warranty, please consult the plumbing professional from whom your water heater was purchased. For your records we recommend that you write the model, serial number and installation date of your water heater in the maintenance section in the back of this manual.

This manual should be kept with the water heater.

GENERAL INFORMATION

Note: It is recommended that the installation and service of this water heater be performed by a plumbing professional.

This water heater must be installed in accordance with local codes. In the absence of local codes, it must be installed in compliance with the National Fire Protection Standard For Oil Burning Equipment NFPA No. 31 (latest edition). In Canada the installation of this water heater shall be in accordance with the regulation of authorities having jurisdiction and CSA STANDARD B139.

The warranty of this water heater is in effect only when the water heater is installed, adjusted, and operated in accordance with these installation and operating instructions.

DO NOT use this appliance if any part has been submerged in water. You should contact the plumbing professional who installed the water heater to inspect the appliance and to replace any part of the control system and any component which has been submerged in water.

A sacrificial anode is used to extend tank life. The removal of this anode, for any reason, will nullify the warranty. In areas where water is unusually reactive, an odor may occur at the hot water faucet due to a reaction between the sacrificial anode and the impurities in the water. If this should happen, an alternative anode may be purchased from the supplier that sold you this water heater. This will minimize the odor while protecting the tank. Additionally, the water heater should be flushed with appropriate dissolvers to eliminate any bacteria.

CAUTION

THESE UNITS ARE DESIGNED FOR FUELS NOT HEAVIER THAN NO. 2 FUEL OIL (FURNACE FUEL). DO NOT USE GASOLINE, CRANKCASE DRAINING'S, OR ANY OIL CONTAINING GASOLINE.

INSTALLATION

Locating the water heater

The location of this water heater is of the utmost importance. Before installing the water heater, you should select a location where the floor is level and is easily accessible to water supply lines as well as to a chimney or vent. **DO NOT** locate the water heater where water lines could be subjected to freezing temperatures.

This water heater MUST be installed indoors out of the wind and weather.

To comply with NSF requirements this water heater is to be:

- a) Sealed to the floor with sealant, in a smooth and easily cleanable way, or
- b) Installed with an optional adjustable water heater stand or leg kit that provides a minimum clearance of 6" beneath the water heater.

Note: For California installation this water heater must be braced, anchored, or strapped to avoid falling or moving during an earthquake. See instructions for correct installation procedures. Instructions may be obtained from the DSA Headquarters, 1102 Q Street Suite 5100, Sacramento, CA 95811.

MINIMUM CLEARANCES

This water heater shall be installed on NON-COMBUSTIBLE flooring only. This water heater may be installed in an alcove. Refer to the marking on the front of the water heater for clearances to combustible materials.

The installation should allow access to the front of the water heater and adequate clearance should be provided for servicing and operating the water heater. It is recommended that a minimum clearance of 3" be provided on the side of the water heater for servicing and maintenance of the temperature and pressure relief valve. **If the rating plate or the label on the front of the water heater specifies minimum clearances less than those listed in the below table, the water heater should be installed in accordance with the minimum clearances listed on the rating plate or the label on the front of the water heater.**

MINIMUM CLEARANCES TO COMBUSTIBLE MATERIALS					
MODEL	REAR	SIDES	FRONT	VENT PIPE	ABOVE
CF-32	6" (15.2cm)	6" (15.2cm)	24" (60.9cm)	9" (22.8cm)	18" (45.7cm)
CF-50					
CF-70					
CF-38					
CF-80					
CF-100					
CDW170L					
RF-30	18" (45.7cm)	6" (15.2cm)	24" (60.9cm)	9" (22.8cm)	6" (15.2cm)
RF-30SX					
RF-50					
RF-70					

This water heater must be located in an area where leakage of the tank or water line connections will not result in damage to the area adjacent to the water heater or to lower floors of the structure. When such locations cannot be avoided, a suitable drain pan must be installed under the water heater. The drain pan must have a minimum length and width of at least 4 in. (10.2 cm) greater than the diameter of the water heater and must not restrict proper combustion air flow to the water heater. The drain pan, as described above, can be purchased from your plumbing professional. The piping must be at least 3/4" in diameter and pitched for proper drainage. The pan must not restrict the combustion airflow.

WARNING

Water heaters are heat-producing appliances. To avoid damage or injury, there shall be no materials stored against the water heater. Proper care shall be taken to avoid unnecessary contact (especially by children) with the water heater. **UNDER NO CIRCUMSTANCES SHALL FLAMMABLE MATERIALS, SUCH AS GASOLINE OR PAINT THINNER, BE USED OR STORED IN THE VICINITY OF THIS WATER HEATER OR IN ANY LOCATION FROM WHICH FUMES COULD REACH THE WATER HEATER.**

NOTE: THE FAILURE TO ADHERE TO THESE INSTRUCTIONS MAY CREATE A HAZARD TO LIFE AND PROPERTY AND WILL NULLIFY THE WARRANTY.

Water heater corrosion and component failure can be caused by heating and breakdown of airborne chemical vapors. Examples of typical compounds that are potentially corrosive are: spray can propellants, cleaning solvents, refrigeration and air conditioning refrigerants, swimming pool chemicals, calcium and sodium chloride, waxes and process chemicals. These materials are corrosive at very low concentration levels with little or no odor to reveal their presence.

NOTE: DAMAGE TO THE WATER HEATER CAUSED BY EXPOSURE TO CORROSIVE VAPORS IS NOT COVERED BY WARRANTY.

CAUTION

THE FLOW OF COMBUSTION AND VENTILATING AIR MUST NOT BE OBSTRUCTED.

COMBUSTION AIR SUPPLY

Installation of this water heater requires that provisions be made to supply adequate air for combustion and ventilation. If the building is unusually tight or if this water heater is installed in a small room, provisions for additional makeup air must be provided. This air must be supplied through two permanent openings located so that the lower edge of the lower opening is 6 inches below the top of the enclosure.

The minimum free air area for such openings shall not be less than one square inch per 1000 BTU/HR of the total input rating of all appliances in that enclosure of 100 square inches, whichever is greater. For outside air, in the absence of local codes, refer to the National Fire Protection Standard for Oil Burning Equipment NFPA No. 31 (latest edition), or CSA B139 (latest edition).

ELECTRICAL CONNECTIONS

This water heater is normally wired for 120Volts / 15amp / 60Hz and shall be electrically grounded in accordance with local codes, or in the absence of local codes, with the National Electrical Code, ANSI/NFPA No. 70 (latest edition), or Canadian Electrical Code, Part 1 (latest edition).

If any of the original wiring must be replaced, replacement shall be with 105°C (221°F) wire or equivalent.

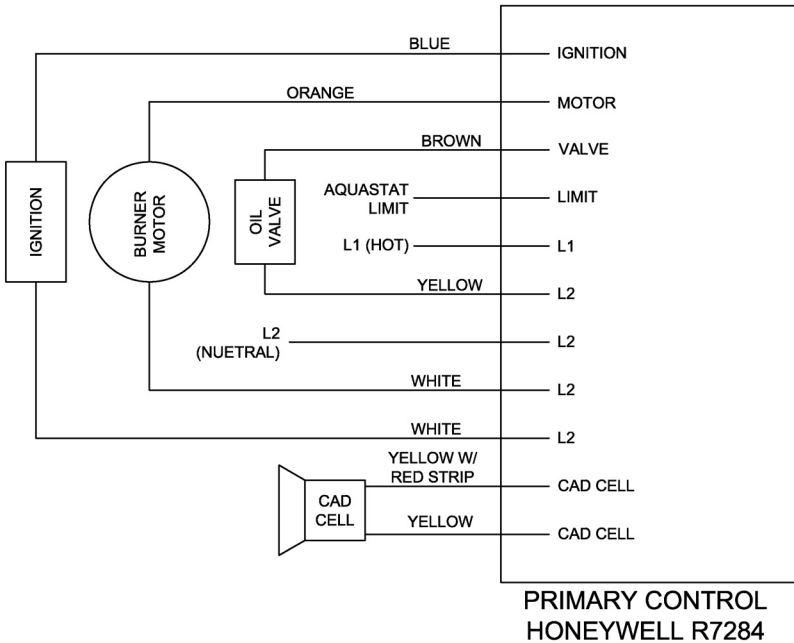

Figure 1

VENTING

The connection from the water heater vent to the stack must be made as direct as possible and of the same diameter as the vent outlet. The recommended slope of any horizontal breaching is at least 1/2" rise per linear foot. A certified draft regulator (barometric damper) shall be installed in the venting with a location at least 18" downstream from the water heater. This water heater is designed for use with type "L" venting.

CAUTION

The stack must extend at least (3) feet above the highest point of the roof to insure proper venting. The stack should be provided with a weather cap of approved design.

Note: Provisions shall be made to prevent contact of the vent pipe with combustible materials in accordance with all codes and regulations.

A separate vent and barometric damper for each appliance is strongly recommended, consult the National Fire Protection Standard For Oil Burning Equipment NFPA No. 31 (latest edition) or CSA B139 (latest edition), for vent sizing and installation information.

WARNING

Draft reading in the stack should be $-.02$ " W.C. to $-.05$ " W.C. High draft may be caused by over firing, or too much excess air. If there is back draft caused by down draft, **DO NOT** operate the burner until this situation is corrected. Back pressure (back draft or down draft) may also be caused by the chimney termination being lower in elevation than surrounding objects, such as buildings, hills, trees, rooftops, etc. Back pressure may also be caused by an exhaust fan in the building.

WATER CONNECTIONS

Note: *BEFORE PROCEEDING WITH THE INSTALLATION, CLOSE THE MAIN WATER SUPPLY VALVE.*

After shutting off the main water supply, open a faucet to relieve the water line pressure to prevent any water from leaking out of the pipes while making the water connections to the water heater. After the pressure has been relieved, close the faucet. The COLD water inlet and HOT water outlet are identified on the top of the water heater. The fittings at the cold water inlet and hot water outlet are dielectric waterway fittings. Make the proper plumbing connections between the water heater and the plumbing system to the house. Install a shut-off valve in the cold water supply line.

CAUTION

If sweat fittings are to be used, **DO NOT** apply heat to the nipples on top of the water heater. Sweat the tubing to the adapter before fitting the adapter to the water connections. It is imperative that heat is not applied to the nipples containing a plastic liner.

If this water heater is installed in a closed water supply system, such as the one having a back-flow preventer in the cold water supply, provisions shall be made to control thermal expansion. **DO NOT** operate this water heater in a closed system without provisions for controlling thermal expansion. Your water supplier or local plumbing inspector should be contacted on how to control this situation.

After installation of the water lines, open the main water supply valve and fill the water heater. While the water heater is filling, open several hot water faucets to allow air to escape from the water system. When a steady stream of water flows through the faucets, close them and check all water connections for possible leaks. **NEVER OPERATE THE WATER HEATER WITHOUT FIRST BEING CERTAIN IT IS FILLED WITH WATER.**

WARNING

FAILURE TO INSTALL AND MAINTAIN AN APPROPRIATE, LISTED TEMPERATURE AND PRESSURE RELIEF VALVE WILL RELEASE THE MANUFACTURER FROM ANY CLAIM, WHICH MIGHT RESULT FROM EXCESSIVE TEMPERATURE AND PRESSURES.

▲ WARNING

For protection against excessive temperatures and pressure, install temperature and pressure protective equipment required by local codes, but not less than a combination temperature and pressure relief valve certified by a nationally recognized testing laboratory that maintains periodic inspection of production of listed equipment or materials as meeting the requirements of the Standard for Relief Valves and Automatic Gas Shutoff Devices for Hot Water Supply Systems, ANSI Z21.22 or the Standard CAN1-4.4, Temperature and Pressure and the Standard CAN1-4.4, Temperature, Pressure, Temperature and Pressure Relief Valves and Vacuum Relief Valves. The combination temperature and pressure relief valve shall be marked with a maximum set pressure not to exceed the maximum working pressure of the water heater. The combination temperature and pressure relief valve shall also have an hourly rated temperature steam BTU discharge capacity not less than the hourly rating of the water heater.

Install the combination temperature and pressure relief valve into the opening provided and marked for this purpose on the water heater.

Note: Some models may already be equipped or supplied with a combination temperature and pressure relief valve. Verify that the combination temperature and pressure relief valve complies with local codes. If the combination temperature and pressure relief valve does not comply with local codes, replace it with one that does. Follow the installation instructions above on this page.

Install a discharge line so that water discharged from the combination temperature and pressure relief valve will exit within 6 inches (15.2 cm) above, or any distance below the structural floor and cannot contact any live electrical part. The discharge line is to be installed to allow for complete drainage of both the combination temperature and pressure relief valve and the discharge line. The discharge opening must not be subjected to blockage or freezing. DO NOT thread, plug or cap the discharge line. It is recommended that a minimum clearance of 4 inches (10.2 cm) be provided on the side of the water heater for servicing and maintenance of the combination temperature and pressure relief valve.

Do not place a valve between the combination temperature and pressure relief valve and the tank.

Installation (Water Connections) continued-

⚠ WARNING

Hydrogen gas can be produced in an operating water heater that has not had water drawn from the tank for a long period of time (generally two weeks or more). Hydrogen gas is extremely flammable. To prevent the possibility of injury under these conditions, we recommend the hot water faucet to be open for several minutes at the kitchen sink before you use any electrical appliance, which is connected to the hot water system. If hydrogen is present, there will be an unusual sound such as air escaping through the pipes as hot water begins to flow. Do not smoke or have open flame near the faucet at the time it is open.

This water heater can deliver scalding temperature water at any faucet in the system. Be careful whenever using hot water to avoid scalding injury. Certain appliances such as dishwashers and automatic clothes washers may require increased temperature water. By setting the thermostat on this water heater to obtain the increased temperature water required by these appliances, the potential for scald injury increases. To protect against injury, you should install an ASSE approved mixing valve in the water system. This valve will reduce point of discharge temperature by mixing cold and hot water in branch supply lines. Such valves are available from the manufacturer of this water heater or a local plumbing supplier. Please consult with a plumbing professional.

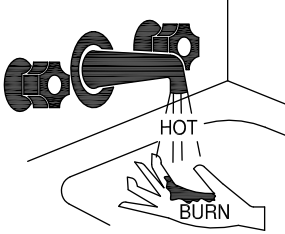
<p>⚠ DANGER</p> 	<p>Water temperature over 125°F (52°C) can cause severe burns instantly or death from scalds.</p> <p>Children, disabled and elderly are at highest risk of being scalded.</p> <p>Review this instruction manual before setting temperature at water heater.</p> <p>Feel water before bathing or showering.</p> <p>Temperature limiting valves are available.</p>
---	--

APPROXIMATE TIME/TEMPERATURE RELATIONSHIPS IN SCALDS	
120°F (49°C)	More than 5 minutes
125°F (52°C)	1½ to 2 minutes
130°F (54°C)	About 30 seconds
135°F (57°C)	About 10 seconds
140°F (60°C)	Less than 5 seconds
145°F (63°C)	Less than 3 seconds
150°F (66°C)	About 1½ seconds
155°F (68°C)	About 1 second

THE FOLLOWING INSTRUCTIONS ARE FOR INSTALLATION OF:
**GAS WATER HEATERS SUITABLE FOR WATER (POTABLE)
HEATING AND SPACE HEATING**

⚠ CAUTION

If your water heater is equipped with an internal double wall coil, refer to the supplemental instructions supplied with this water heater for proper installation.

1. All water heaters are to be installed in accordance with local codes or, in the absence of such, with CAN/CSA-B214 Installation code for hydronic heating (latest edition).
2. All piping components connected to this water heater for space heating applications must be suitable for use with potable water. In Massachusetts, space heating piping length **must not** exceed 50 feet.
3. Toxic chemicals, such as those used for boiler treatment, **must not** be introduced into potable water used for space heating.
4. This water heater **must not** be connected to an existing heating system or component(s) previously used with a non-potable water heating appliance.
5. When the system requires water for space heating at temperatures higher than required for other means, such as an ASSE approved mixing valve shall be installed to temper the water for those uses in order to reduce the scald hazard potential.

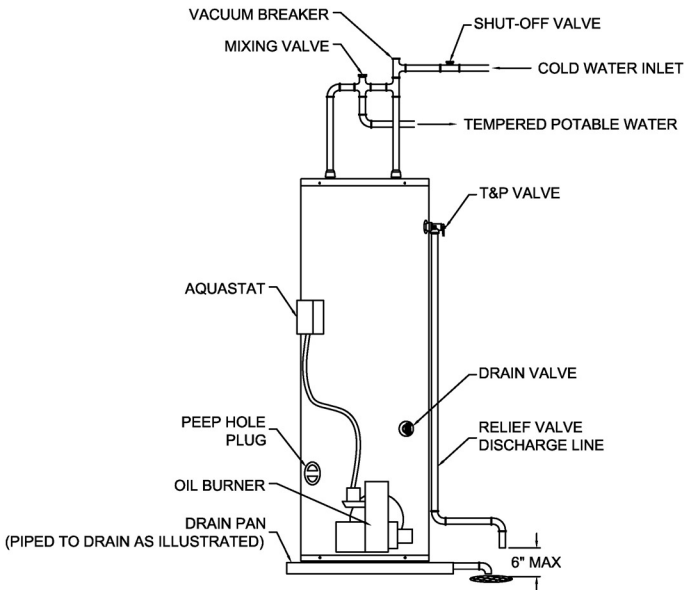

Figure 2 – Suggested piping arrangement

OIL TANKS AND PIPING

CAUTION

The instructions in this section are general guidelines. The instructions for the specific pump installed on the burner that you have purchased should take precedence over the instructions given below. Read all of the instructions provided with the burner before continuing with the installation.

WARNING

To prevent an oil leak and/or fire hazard, install the oil tank following applicable standards in the U.S. by referring to the latest edition of NFPA 31 or CSA-B139 & CSA-B140 in Canada, and all authorities having jurisdiction.

CAUTION

DO NOT use thread sealing tape. Damage to the pump could cause impaired burner operation, oil leakage and appliance soot-up. Never use thread sealing tape on fuel oil fittings. Tape fragments can lodge in fuel line components and fuel unit, damaging the equipment and preventing proper operation. Use oil-resistant pipe sealant compounds.

IMPORTANT

To determine the proper fuel line size, refer to the fuel pump manufacturer's instructions provided with the burner. Refer to Figure 3 or Figure 4 for typical installation layouts.

CAUTION

If the residence is unattended in severely cold weather, burner primary control safety lockout, heating system component failures, power outages or other electrical system failures could result in frozen plumbing and water damage in a matter of hours. For protection, take preventive actions such as having a security system installed that operates during power outages, senses low temperature and initiates an effective action. Consult with your heating contractor or a home security agency.

**Oil tanks and Piping Continued-
Fuel Line Valves and Filter**

Install (2) high quality, oil duty rated, fusible handle design shutoff valves in accessible locations on the oil supply line. Locate one close to the tank and the other close to the burner, upstream of the filter for service access.

Install a generous capacity filter inside the building between the fuel tank shutoff valve and the burner, locating both the filter and the valve close to the burner for ease of servicing. Filter should be rated for 50 microns or less.

To further protect the fuel supply system and reduce nozzle orifice plugging with firing rates below 0.75 gph, a dual filtration system can be installed. This typically consists of a 50 micron primary filter, located near the fuel tank and a secondary filter rated for at least 10 microns located near the burner.

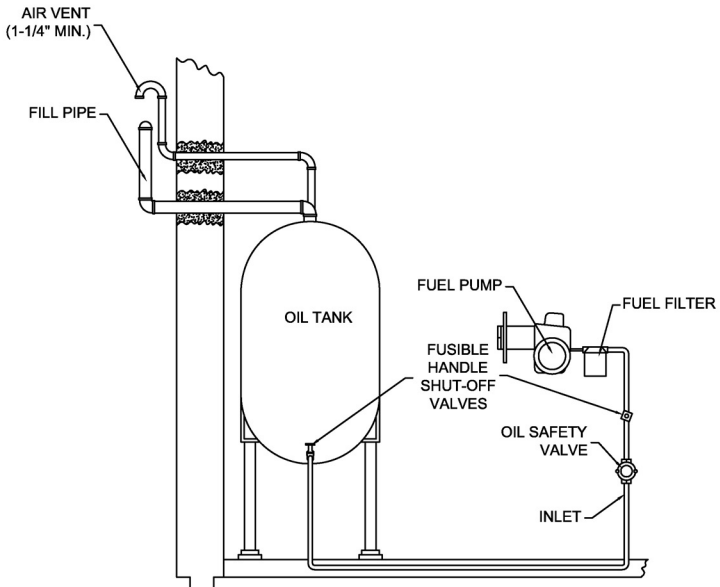

Figure 3

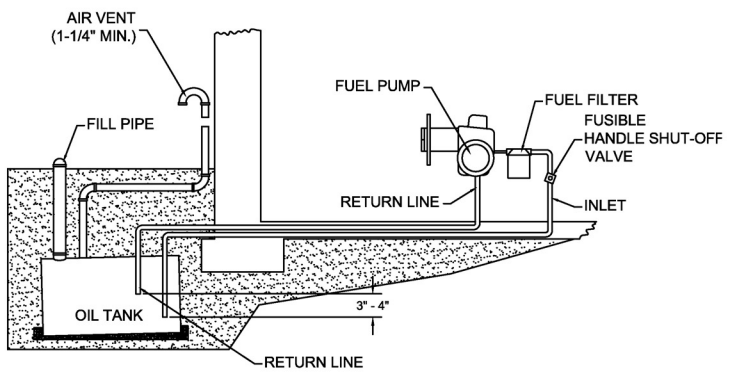

Figure 4

Fuel supply LEVEL with or ABOVE burner

⚠ WARNING

DO NOT install by-pass plug with 1-pipe system. Failure to comply could cause immediate pump seal failure, pressurized oil leakage and the potential for a fire and injury hazard. The burner is shipped without the by-pass plug installed. Install the by-pass plug in 2-pipe oil supply systems **ONLY**.

⚠ CAUTION

Oil supply pressure control is required. Damage to the filter or pump seals could cause oil leakage and a fire hazard. The oil supply inlet pressure to the burner **CANNOT** exceed 3 psi. Insure that a pressure limiting device is installed in accordance with the latest edition of NFPA 31.
DO NOT install valves in the return line (refer to NFPA 31).
For gravity feed systems, always install an anti-siphon valve in the oil supply line or a solenoid valve in the pump/nozzle discharge tubing to provide backup oil flow cut-off protection.

The burner may be equipped with a single-stage fuel unit for these installations. Connect the fuel supply to the burner with a single supply line if you want a 1-pipe system (making sure the bypass plug is **NOT** installed in the fuel unit). Manual bleeding of the fuel unit is required on initial start-up. If connecting a 2-pipe fuel supply, install the fuel unit bypass plug.

Fuel supply BELOW the level of the burner

When the fuel supply is more than (8) feet below the level of the burner, a 2-pipe fuel supply system is required. Depending on the fuel line diameter and horizontal and vertical length, the installation may also require a 2-stage pump. Consult the fuel unit manufacturer's literature, included with the burner, for lift and vacuum capability.

Fuel line installation

Continuous lengths of heavy wall copper tubing are recommended. Always use flare fittings. Never use compression fittings. Always install fittings in accessible locations. Proper routing of fuel lines is required to prevent air cavitation and vibration.

OPERATION

TO FILL THE WATER HEATER

1. Close the water heater drain valve by turning the handle clockwise.
2. Open the cold water shut-off valve.
3. Open several hot water faucets to allow air to escape from the system.
4. When a steady stream of water flows at the hot water faucets, the water heater is filled. Close the faucets and check for water leaks at the temperature-pressure relief valve and the hot and cold water connections.

TO DRAIN THE WATER HEATER

Should it become necessary to completely drain the water heater, make sure you follow the steps below:

1. Shut off the oil supply to the water heater.
2. Turn off/disconnect all electric power to the water heater.
3. Close the cold water supply shut-off valve.
4. Open a hot water faucet to allow air to enter the system.
5. Open the drain valve. This is threaded to receive a standard hose coupling.



To put the water heater back into operation, refer to "To Fill the Water Heater".

BURNER AND THERMOSTAT INFORMATION

It is recommended that this water heater be installed with the following burners and thermostat:

Table 1

MODEL SIZE	BURNER	NOZZLE FIRING RANGE	THERMOSTAT
CF-32	Beckett AFG Burner (BW501)	0.65 - 0.75 X 80° B @ 100 PSI	Honeywell Electronic Aquastat (L7103) Max. temp. 160°F (71°C)
	Riello (F3)	0.55 X 60° W @ 140 PSI	
		0.60 X 45° B @ 155 PSI	
	Carlin EZ-1 (96845C32)	0.65 X 70° A @ 100 PSI	
0.75 X 70° A @ 100 PSI			
CF-50	Beckett AFG Burner (BW502)	0.75 - 0.85 X 80° B @ 100 PSI	Honeywell Electronic Aquastat (L7103) Max. temp. 160°F (71°C)
	Riello (F3)	0.75 X 45° AB @ 155 PSI	
		0.65 X 45° B @ 170 PSI	
	Carlin EZ-1 (96845C50)	0.75 X 60° A @ 100 PSI	
0.85 X 60° A @ 100 PSI			
CF-70 CDW170L	Beckett AFG Burner (BW506)	0.85 X 80° B @ 100 PSI	Honeywell Electronic Aquastat (L7103) Max. temp. 160°F (71°C)
	Riello (F5)	0.65 X 45° B @ 170 PSI	
	Carlin EZ-1 (96845C50)	0.85 X 60° A @ 100 PSI	
CF-38	Beckett AFG Burner (BW509)	1.75 - 2.50 X 80° B @ 100 PSI	Honeywell Electronic Aquastat (L7103) Max. temp. 160°F (71°C)
	Riello (F10)	1.50 X 45° B @ 135 PSI	
		1.65 X 45° B @ 150 PSI	
		1.75 X 45° B @ 165 PSI	
		2.00 X 45° B @ 155 PSI	
	Carlin EZ-66 (50648C38)	1.75 X 60° B @ 100 PSI	
		2.00 X 60° W @ 100 PSI	
		2.25 X 60° W @ 100 PSI	
2.50 X 60° W @ 100 PSI			
CF-80	Beckett SF Burner (BW703)	3.50 - 5.00 X 80° B @ 100 PSI	Honeywell Mechanical Aquastat (L8100) Max. temp. 180°F (83°C)
	Riello (F15)	3.00 X 45° AB @ 135 PSI	
		3.50 X 45° S @ 130 PSI	
		3.75 X 80° B @ 145 PSI	
		4.00 X 60° SS @ 155 PSI	
	Carlin 301CRD (50650C80)	3.50 X 80° B @ 100 PSI	
		4.00 X 80° B @ 100 PSI	
		4.50 X 80° B @ 100 PSI	
5.00 X 80° B @ 100 PSI			
CF-100	Beckett SF Burner (BW701)	2.50 - 3.00 X 80° B @ 100 PSI	Honeywell Mechanical Aquastat (L8100) Max. temp. 180°F (83°C)
	Riello (F15)	2.00 X 45° W @ 155 PSI	
		2.50 X 45° W @ 144 PSI	
	Carlin 102CRD-3 (50649C10)	2.50 X 70° A @ 100 PSI	
3.00 X 60° W @ 100 PSI			

Table 1 cont.

MODEL SIZE	BURNER	NOZZLE FIRING RANGE	THERMOSTAT
RF-30SX	Beckett AFG Burner (BW503)	0.85 X 80° B @ 100 PSI	Honeywell Electronic Aquastat (L7103) Max. temp. 160°F (71°C)
	Riello (F3)	0.65 X 60° AS @ 145 PSI	
	Carlin EZ-1 (96845C50)	0.85 X 60° A @ 100 PSI	
RF-50	Beckett AFG Burner (BW504)	1.25 - 1.35 X 80° B @ 100 PSI	Honeywell Electronic Aquastat (L7103) Max. temp. 160°F (71°C)
	Riello (F5)	1.0 X 60° B 2.0 @ 155 PSI	
	Carlin EZ-1 (96845R50)	1.25 X 60° B @ 100 PSI	
		1.35 X 60° B @ 100 PSI	
RF-70	Beckett AFG Burner (BW507)	1.50 - 1.75 X 80° B @ 100 PSI	Honeywell Electronic Aquastat (L7103) Max. temp. 160°F (71°C)
	Riello (F5)	1.10 X 60° B @ 150 PSI	
	Carlin EZ-2 (50647R70)	1.50 X 60° A @ 100 PSI	
		1.75 X 60° A @ 100 PSI	

T'stat information Continued-

The correct burners and thermostat may be purchased from the same supplier that provided the water heater to you.

Installing the Burner: It is recommended that the burner be installed so that the face of the burner head is between 1/8" to 5/8" from the sides of the inside wall of the combustion chamber (see Figure 5). Note the top and bottom distances may vary slightly due to the curvature of the combustion chamber. The recommended burners are designed so the burner head will be at its optimal distance to the combustion chamber. The position of the burner head can be checked by viewing it through the peep hole using a mirror. The burner is secured to the water heater by three 5/16" nuts.

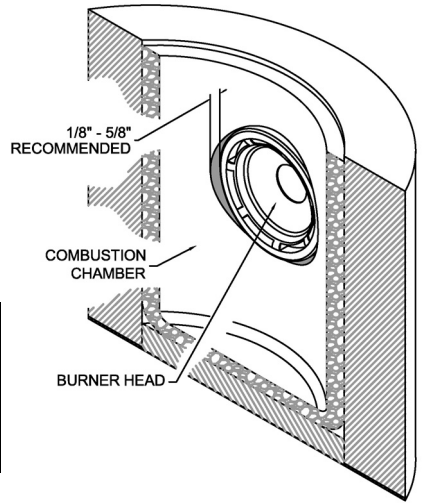

Figure 5

Installing the Thermostat: This water heater comes with the thermostat well installed in the tank. A Honeywell Aquastat needs to be installed. Refer to Table 1 for appropriate thermostat information.

Adjusting the Thermostat: When adjusting the thermostat it should be remembered that lower temperature settings are more energy efficient. It is suggested that the starting setting not exceed 120°F as displayed in Figure 6. Thermostat adjustment instructions are as follows:

Honeywell Mechanical (L8100) thermostat: turn the dial clockwise to decrease the temperature and counter-clockwise to increase the temperature.

Honeywell Electronic (L7103) thermostat: enter the adjustment mode by pressing the "UP", "DOWN", and "I" buttons (see Figure 4) simultaneously for three seconds. Press the "I" button until the feature requiring adjustment is displayed (SET=Setpoint; °F-°C). Then press the "UP" or "DOWN" buttons to move the setpoint to the desired value. After 60 seconds, without any button inputs, the control will automatically return to the READ mode.

T'stat information Continued-

This water heater can deliver scalding temperature water at any faucet in the system. Be careful whenever using hot water to avoid scalding injury. Certain appliances such as dishwashers and automatic clothes washers may require increased temperature water. By setting the thermostat on this water heater to obtain the increased temperature water required by these appliances, the potential for scald injury increases. To protect against injury, you should install an ASSE approved mixing valve in the water system. This valve will reduce point of discharge temperature by mixing cold and hot water in branch supply lines. Such valves are available from the manufacturer of this water heater or a local plumbing supplier. Please consult with a plumbing professional.

⚠ CAUTION

Hotter water increases the risk of scald injury. Scalding may occur within five (5) seconds at a temperature setting of 140°F. To protect against hot water scald injury, install an anti-scald tempering valve in the water system. This valve will reduce point of discharge temperature by mixing cold and hot water in branch water lines. A qualified plumber should be consulted.

⚠ DANGER

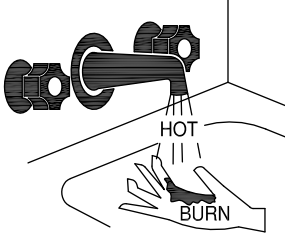

Water temperature over 125°F (52°C) can cause severe burns instantly or death from scalds.

Children, disabled and elderly are at highest risk of being scalded.

Review this instruction manual before setting temperature at water heater.

Feel water before bathing or showering.

Temperature limiting valves are available.

APPROXIMATE TIME/TEMPERATURE RELATIONSHIPS IN SCALDS	
120°F (49°C)	More than 5 minutes
125°F (52°C)	1½ to 2 minutes
130°F (54°C)	About 30 seconds
135°F (57°C)	About 10 seconds
140°F (60°C)	Less than 5 seconds
145°F (63°C)	Less than 3 seconds
150°F (66°C)	About 1½ seconds
155°F (68°C)	About 1 second

T'stat information Continued-

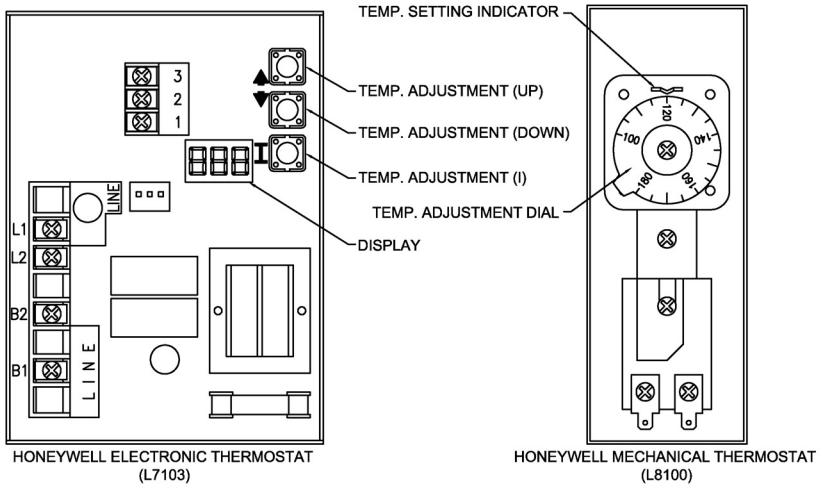

Figure 6 – Thermostats with cover removed

⚠ WARNING

Escaping flue gases can be lethal. Make sure that the flue and venting system is checked at least once a year by a plumbing professional or the oil supplier's service technicians.

Motor Lubrication: Oil motor with one or two drops of non-detergent motor oil.

Priming The Fuel Units: Locate the air bleed valve on the fuel unit (pump). Place a container underneath the air bleed valve. Open the air bleed valve by turning it one quarter of a turn in the counter-clockwise direction. Turn the thermostat on the water heater to a setting that is high enough to allow the burner to operate. Turn on the power supply to the burner. After the air is pumped out of the fuel unit, let at least one pint of oil flow into the container. While running under these conditions, the pressure valve in the pump will not open; hence, there will be no flame. When a pint of oil has flowed into the container, close the air bleed valve. The burner should start burning when the air bleed valve is closed.

The above is not necessary when a two-pipe system is used. Install the pressure gauge and turn burner on. The system will vent itself through the return line and flame will appear as soon as the air has been eliminated. In the event a lot of air is present and flame is not sighted within 45 seconds, the cad cell will cause the relay to cut off for protection. It may then be necessary to push the reset button on the burner on the burner module.

⚠ WARNING

DO NOT ATTEMPT TO START THE BURNER WHEN EXCESS OIL HAS ACCUMULATED, WHEN THE UNIT IS FULL OF VAPOR, OR WHEN THE COMBUSTION CHAMBER IS HOT.

TUNE-UP PROCEDURE

- A. To Put The Burner in Operation:** Remove the temporary oil connection previously used and install a pressure gauge. Set all the controls to the normal starting position. Close the main cut out switch. The burner should start, ignite and burn. After you have obtained a flame, the oil pressure should be checked and adjusted to a pressure of 100 psi. This is the normal operating pressure. The air inlet can then be adjusted so that the flame is a clean yellow with slightly smoky tips. The burner flame can be observed through the peep site hole. It may be necessary to readjust the air inlet after the burner is running twenty minutes or more in order to obtain the proper fire with a hot combustion chamber. After final adjustment, tighten lock screws on air inlet, let unit cool and restart burner to be sure burner operates on a cold start. Remove the pressure gauge and install pipe plug.
- B. Using Instruments To Set Fire:** It is strongly suggested that the installer use combustion test instruments when adjusting a flame. We suggest 9 1/2% to 11% CO₂ with a smoke reading no darker than 1 on the Bachrach Scale. Adjust the air inlet on the burner for the minimum amount of air for clean combustion while the combustion chamber is hot. Adjust the draft regulator so that there is -.01" to -.04" draft over the fire, maximum. Take readings and adjust air so that a minimum of 9 1/2% CO₂ is obtained with a smoke reading between 0 and 1. When using instruments in setting a fire, do not lean towards getting a greater percentage of CO₂ than a clean fire will give. It is more important to keep the inside of the combustion system clean than to receive a higher CO₂.
- C. Nozzle (Oil Input) Variations:** Oil service personnel will carry several nozzles of different manufacture, angles and types of spray in order to obtain the most suitable for the particular application. Fuel oils vary greatly. Because of this, nozzles will not always deliver the gallons per hour or angle of spray that is indicated on the nozzle. In addition, it has been found that, in certain areas, due to local conditions, nozzles other than those furnished as original equipment, give better performance due to the type of oil being delivered.

⚠ WARNING

Draft reading in the stack should be $-.02''$ W.C. to $-.05''$ W.C. High draft may be caused by over firing, or too much excess air. If there is back draft caused by down draft, DO NOT operate the burner until this situation is corrected. Back pressure (back draft or down draft) may also be caused by the chimney termination being lower in elevation than surrounding objects, such as buildings, hills, trees, rooftops, etc. Back pressure may also be caused by an exhaust fan in the building.

IMPORTANT REMINDERS

1. Install all electrical work in strict accordance with local codes and ordinances.
2. All unions must be of the ground seat type.
3. A check valve shall be installed in the suction line when the oil storage tank is below the burner to prevent the return of the oil to the oil storage tank when the fuel unit is not in operation.
4. Lubricate oil burner motor.
5. Set the draft to a range of $-.02''$ W.C. to $-.05''$ W.C.
6. See that the smoke pipe enters into the chimney far enough to be tight and not so far as to reduce flue area. Its end should be flush with the inside of the chimney.
7. Be sure that there is at least $-.01''$ W.C. draft over the fire.
8. Be sure that there is no backpressure such as down draft or back draft.
9. Be sure that there is sufficient air in heater room for proper combustion at all times.
10. Explain the operation of the burner to the owner -show where to oil -how to operate controls and main cutout switch.
11. Hang burner-operating instructions as supplied with burner in prominent place near installation.

⚠ CAUTION

Hydrogen gas can be produced in a hot water system served by this water heater that has not been used for a long period of time (generally two weeks or more). Hydrogen gas is extremely flammable. To reduce the risk of injury under these conditions, it is recommended that the hot water faucet be opened for several minutes at a convenient sink before using any electrical appliance connected to the hot water system. If hydrogen is present, there will probably be an unusual sound such as air escaping through the pipe as the water begins to flow. There shall be no smoking or open flame near the faucet at the time it is open.

MAINTENANCE

In addition, the following steps should be performed at six-month intervals unless otherwise specified:

1. Make sure you clear the combustion air openings of any dust, lint or other restrictions. Flow of combustion air **MUST NOT** be restricted.
2. Check the burner flame periodically. If it becomes out of shape or smoky, call your service technician.
3. When cleaning your heater room or utility room, always turn off the burner to reduce the amount of dust and lint drawn into the burner.
4. The electric ignition system and all controls should be checked periodically for reliability of operation and adjusted if necessary.
5. Lightly oil the burner motor with "Medium" detergent-free automobile engine oil twice per year.
6. Clean Strainer or Filter as follows:
 - a) Oil valves between oil storage tank and burner should be shut.
 - b) Remove Strainer cover.
 - c) Remove Strainer baskets and wash in kerosene.
 - d) Reassemble.
7. Drain off at least one gallon of water each month to remove the silt and sediment from the water heater.

CAUTION: THIS WATER MAY BE HOT.

8. Check the temperature-pressure relief valve to insure that the valve has not become inoperable. Lift the lever at the top of the valve several times until the valve seats properly without leaking and operates freely.

CAUTION: THIS WATER MAY BE HOT.

WARNING

When lifting the lever of the temperature and pressure relief valve, hot water will be released under pressure. Be certain that any released water does not result in bodily injury or property damage.

If the temperature and pressure relief valve on the water heater discharges periodically, this may be due to thermal expansion in a closed water supply system. Please contact your water supplier or plumbing professional on how to correct this situation. Do not plug the temperature and pressure relief valve.

Either a plug type, combination anode/nipple or both have been installed in this water heater to extend tank life. The anode(s) should be inspected periodically (every 2 years) and replaced if necessary. Contact the installing professional plumber or the manufacturer listed on the rating plate for replacement anode information. The use of a water softener may increase the speed of anode consumption. More frequent inspection of the anode is needed when using softened (or phosphate treated) water. You should contact your supplier or a plumbing professional for replacement parts. Make sure that you give the Part name, model number and serial number of the water heater when ordering the parts.

Maintenance Continued-

Contact your supplier or plumbing professional for replacement parts or contact the company at the address given on the rating plate of the water heater.

Provide the part name, model and serial numbers of the water heater when ordering parts.

READ THE WARRANTY FOR A FULL EXPLANATION OF THE LENGTH OF TIME THAT PARTS AND THE WATER HEATER ARE WARRANTED.

Manufactured under one or more of the following U.S. Patents: RE.34,534; B1 5,341,770; 4,416,222; 4,628,184; 4,669,448; 4,672,919; 4,808,356; 4,829,983; 4,861,968; 4,904,428; 5,000,893; 5,023,031; 5,052,346; 5,081,696; 5,092,519; 5,115,767; 5,199,385; 5,277,171; 5,372,185; 5,485,879; 5,574,822; 5,596,952; 5,660,165; 5,682,666; 5,761,379; 5,943,984; 5,954,492; 5,988,117; 6,142,216; 6,395,280; 6,684,821; 7,063,132; 7,007,748
Other U.S. and Foreign patent applications pending. Current Canadian Patents: 1,272,914; 1,280,043; 1,289,832; 2,045,862; 2,092,105; 2,107,012; 2,108,186; 2,112,515

Complete the following information and retain for future reference:

Model No: _____

Serial No: _____

Installation Date: _____

Service Phone No.

Days: _____ Nights: _____

Address: _____

Supplier: _____

Supplier's Phone No: _____