

# GB162-100 Condensing Gas Boiler

Engineering  
Submittal  
Sheet

# Buderus

## Boiler Overview

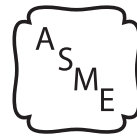

H

## Engineering Specifications

There shall be provided and installed a quantity of \_\_\_\_ Buderus GB162/100 wall-hung condensing hot water boiler(s), suitable for induced draft firing with natural gas or propane. Boiler(s) shall have a minimum AHRI combustion efficiency rating of 96% at part load.

Boiler(s) shall utilize ALUplus heat exchanger with high quality condensing heating surface with plasma polymerization for a longer service life and lower maintenance.

Boiler(s) shall be constructed, tested and labeled in accordance with ASME Section IV and shall bear the ASME stamp. Boilers shall be CSA approved and have an applicable Canadian Registration number.

Heat exchanger shall be labeled for 58psi (4Bar) maximum working pressure rating. An integrated pressure sensor shall ensure minimum and maximum water pressures are not exceeded.

Boiler shall be capable of modulating firing from 100% to 20% of capacity continuously based upon (i) supply and return water temperatures, and/or (ii) outdoor reset computerized control. Gross stack temperatures at full firing rate shall not exceed 180°F (82°C).

Standard equipment shall include a pump group assembly; Grundfos UP26-99 circulator, integral flow check, supply and return shut-off valves, pressure gauge, 30psi (2.6Bar) pressure relief valve and gas supply shut-off valve.

Minimal clearances shall be integral to the boiler cabinet design; a hinged door with locking feature shall be used to access heat exchanger, burner components, gas valve and sensors.

Integrated controller shall monitor and control all combustion process functions, control of the boiler water temperature to a value required by the connected components and shall display current water temperatures or fault conditions with changes in operation status. Additional control functions shall include an on/off button, rotary temperature knobs, LED for burner operation and button for fault condition reset.

Independent outdoor temperature reset may be accomplished with the optional AM10 controller; a mounting enclosure shall be included with the provided resistance dependent sensor.

GB162-100  
Condensing Gas Boiler

**Buderus**

Performance Data			
	Unit	Natural Gas	LP Gas
Gas input	MBH (kW)	333 (98)	315 (92.3)
Gross rated output	MBH (kW)	302 (88.5)	282 (82.6)
IBR Rating	MBH (kW)	263 (77.1)	245 (71.8)
Boiler horsepower	H.P.	9.0	9.0
AHRI thermal efficiency	%	90.8	90.8

General Data		
	Unit	Value
Boiler category	–	Condensing
Heat exchanger construction	–	Aluminum
Maximum allowable working pressure	PSI (bar)	58 (4)
Water content	Gallons (l)	1.3 (5.0)
Weight - shipping (approx.)	Lbs (kg)	189 (85.73)
Weight - operating (approx.)	Lbs (kg)	200 (90.72)
Standard relief valve size (inlet x outlet)	Inch	3/4 x 3/4 M x F NPT
Standard relief valve pressure rating (other capacities available upon request)	PSI (bar)	30 (2.6)
Venting category	–	IV

Operational Data		
	Unit	Value
Maximum supply water temperature	°F (°C)	180 (82)
Minimum return water temperature	°F (°C)	< 40° F (4.44°C) Supply

Electrical Data		
	Unit	Value
Electrical voltage mains	V AC	120
Power consumption max load (with pump group)	Watts	401
Power consumption partial load (with pump group)	Watts	274
Max. permissible fuse rating	Amps	15

Burner Data		
	Unit	Value
Allowable fuels	–	Natural gas, LP
Min Static Inlet Gas Pressure - NG	Inch W.C. (mbar)	5.0 (12.4)
Max Static Inlet Gas Pressure - NG	Inch W.C. (mbar)	10.5 (26.1)
Min Static Inlet Gas Pressure - LP	Inch W.C. (mbar)	8.0 (19.9)
Max Static Inlet Gas Pressure - LP	Inch W.C. (mbar)	13.0 (32.3)

Approval Data	
Approval description	Approval number
Massachusetts Approval #	G3-0809-45
CRN #	7990.7C

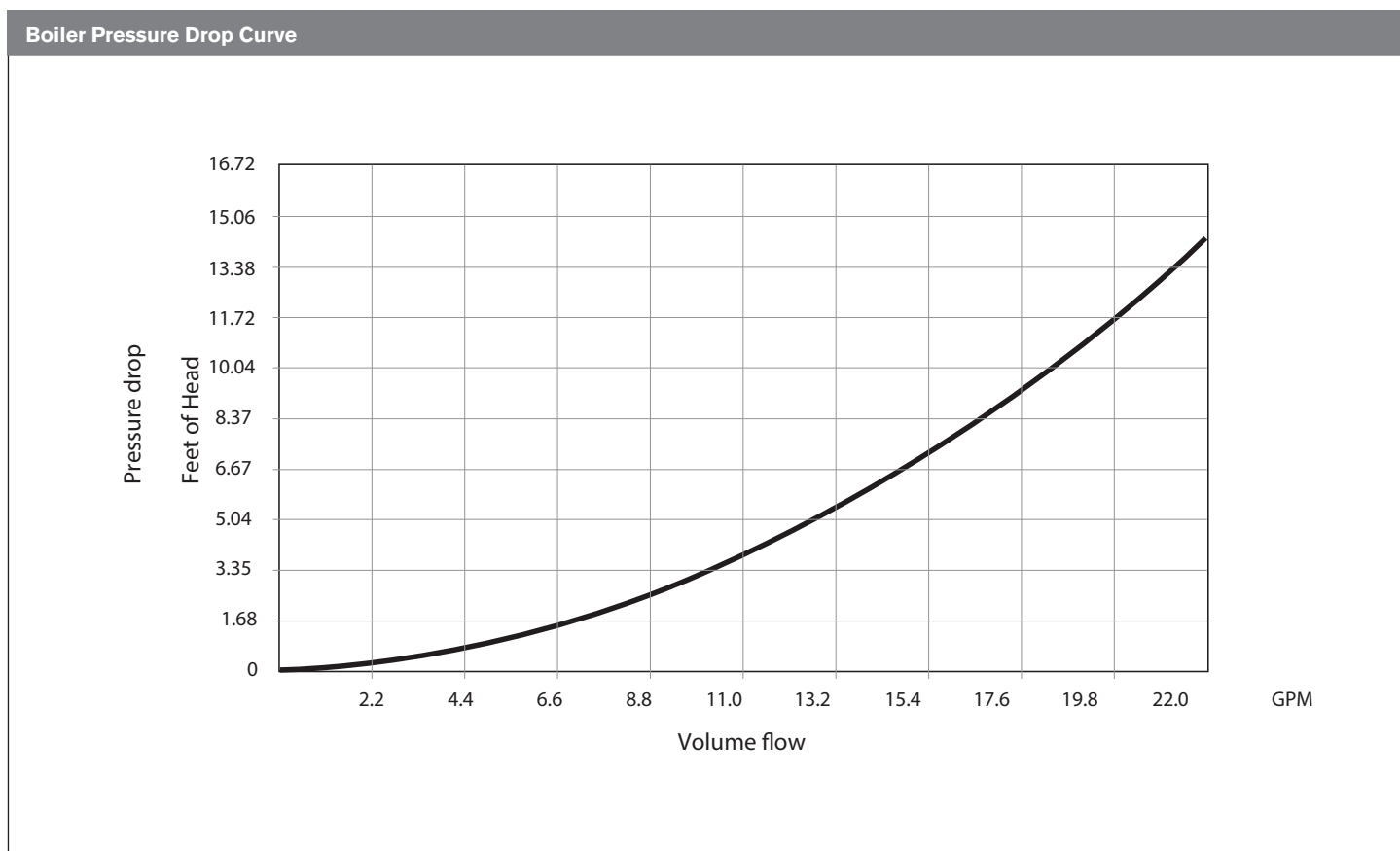

**Boiler Dimensions and Connections with pump group**

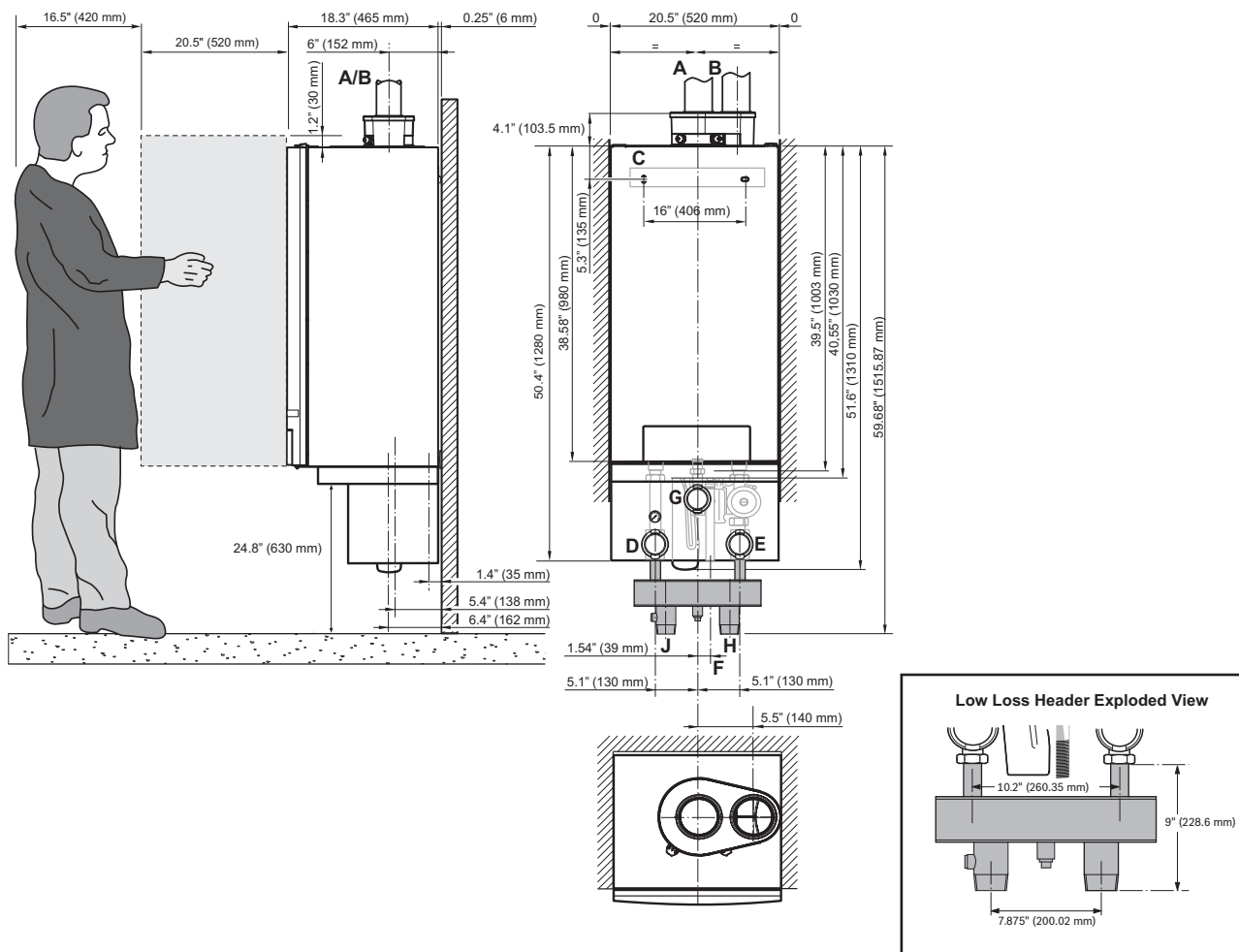

**Boiler Dimensions / Connections Data**

Item	Description	Unit	Value
A	Flue gas connection (inside diameter)	Inch (mm)	4 (100)
B	Air intake (inside diameter)	Inch (mm)	4 (100)
C	Wall bracket	—	—
D	Boiler Supply Isolation Valve	Inch (mm)	—
E	Boiler Return Isolation Valve	Inch (mm)	—
F	Siphon (Condensate Trap)	Inch (mm)	—
G	Boiler Gas Shut-off Valve	Inch (mm)	1 (25.4) FPT
H	Low Loss Header Return Connection	Inch (mm)	2 (51) MPT
J	Low Loss Header Supply Connection	Inch (mm)	2 (51) MPT

Bosch Thermotechnology Corporation  
Londonderry, NH • Ft. Lauderdale, FL • Irvine, CA

**Pump Group / Low Loss Header Overview**

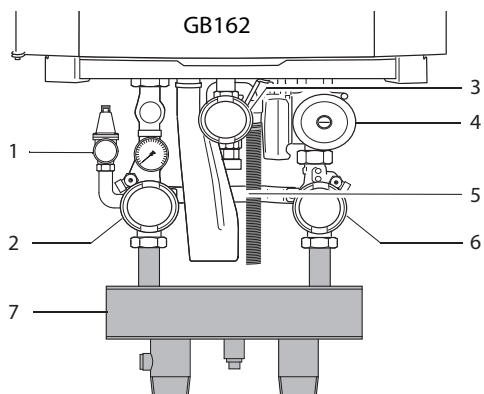

Ref	Description
1	Pressure relief valve
2	Boiler supply isolation valve
3	Manual gas shutoff valve
4	Circulator pump
5	Siphon (Condensate Trap)
6	Boiler return isolation valve
7	Low loss header

\* Pump group cover not shown

\*\* Low Loss Header is used on single boiler installations only

**Grundfos UP 26-99 F Pressure Drop Curve**

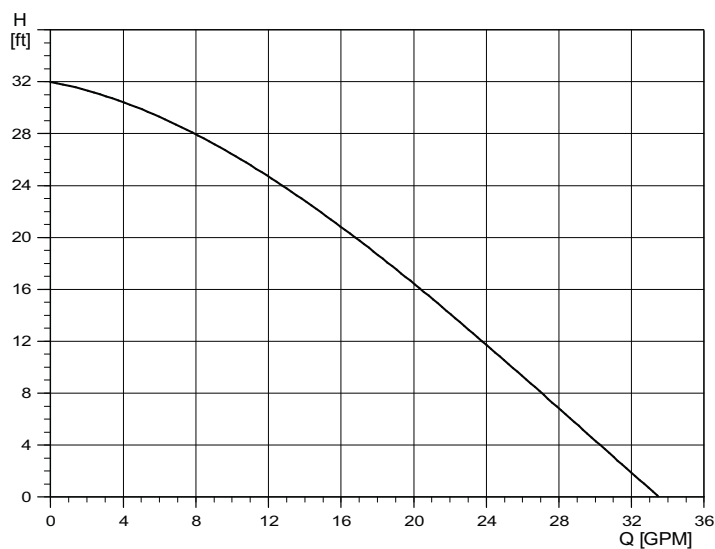

**Boiler Clearances**

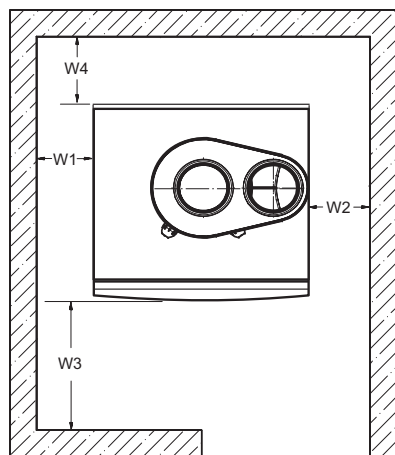

Top View

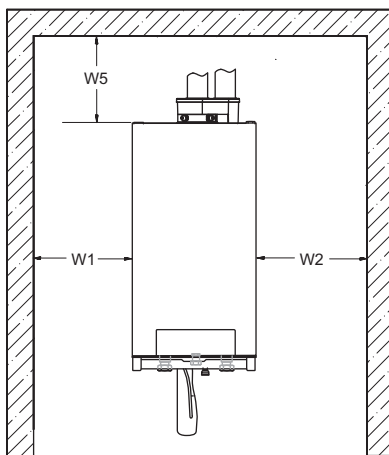

Front View

Description	Unit	Minimum clearance
Wall clearance W1	Inch (mm)	0
Wall clearance W2	Inch (mm)	0
Wall clearance W3	Inch (mm)	37 (940)
Wall clearance W4	Inch (mm)	0
Top clearance W5	Inch (mm)	6 (152)

**DISCLAIMER**

Bosch Thermotechnology Corp. makes no warranty or representation, expressed or implied, with respect to the accuracy, completeness, or usefulness of this information, nor assumes any liability with respect to the use of any information contained within this document.