

## Residential Manufactured Home Direct Vent Energy Saver Gas Water Heater



Photo is of  
RG2DVMH30T6X

### The Manufactured Home Models feature:

- **Housing and Urban Development**—This water heater is designed in accordance with H.U.D. and is certified for installation in a manufactured home (mobile home) only and must be installed in an enclosure that will completely separate the water heater combustion and venting system from the dwelling interior.
- **Sealed Combustion Roof Jack Kit**—Ordered separately and includes an adjustable air intake tube, roof jack and hardware. Must specify roof jack size when ordering. Available in 12", 18"/32", 32"/60" or 48"/95" lengths.
- **Flue Baffle**—Designed to maximize the amount of heat absorbed in the lower portion of tank. Minimizes air movement in the heater during standby periods to decrease heat loss up the flue.
- **Heat Traps**—Installed on hot water outlet to minimize heat loss through piping.
- **Vitraglas<sup>®</sup> Lining**—Bradford White tanks are lined with an exclusively engineered enamel formula that provides superior tank protection from the highly corrosive effects of hot water. This formula (Vitraglas<sup>®</sup>) is fused to the steel surface by firing at a temperature of over 1600°F (871°C).
- **Fully Automatic Controls**—Fast acting surface-mount thermostats for automatic temperature control. Factory-installed sensitive manual reset energy cutoff for safety to prevent overheating.
- **2" Non-CFC Foam Insulation**—Covers the sides and top of tank, reducing the amount of heat loss. This results in less energy consumption, improved operation efficiencies, and jacket rigidity.
- **Water Connections**—3/4" NPT factory-installed true dielectric fittings extend water heater life and ease installation.
- **Protective Magnesium Anode Rod**—Provides added protection against corrosion for long trouble-free service.
- **T&P Relief Valve**—Installed.
- **Low Restriction Brass Drain Valve**—Durable tamper-proof design.
- **Convertible Gas Control**—Easily convertible control for use with either Propane or Natural Gas.



### 6 or 10-Year Limited Tank Warranties / 6 or 10-Year Limited Warranty on Component Parts.

For more information on warranty, please visit [www.bradfordwhite.com](http://www.bradfordwhite.com)

For products installed in USA, Canada and Puerto Rico. Some states do not allow limitations on warranties. See complete copy of the warranty included with the heater.

MANUFACTURED UNDER ONE OR MORE OF THE FOLLOWING U.S. PATENTS: 5,682,666; 7,634,976; 5,660,165; 5,954,492; 6,056,542; 6,935,280; 5,372,185; 5,485,879; 5,574,822; 7,971,560; 7,992,526; 6,684,821; 6,442,178; 7,334,419; 7,866,168; 7,270,087; 7,007,748; 5,596,952; 6,142,216; 7,699,026; 5,341,770; 7,337,517; 7,665,211; 7,665,210; 7,063,132; 7,063,133; 7,559,293; 7,900,589; 5,943,984; 8,082,888; 5,988,117; 7,621,238; 7,650,859; 5,761,379; 7,409,925; 5,277,171; 8,146,772; 7,458,341; 2,262,174. OTHER U.S. AND FOREIGN PATENT APPLICATIONS PENDING. CURRENT CANADIAN PATENTS: 2,314,845; 2,504,824; 2,108,186; 2,143,031; 2,409,271; 2,548,958; 2,112,515; 2,476,685; 2,239,007; 2,092,105; 2,107,012. Vitraglas<sup>®</sup> is a registered trademark of Bradford White<sup>®</sup> Corporation.

# Residential Direct Vent Gas Water Heater

## Manufactured Home Energy Saver Models

NATURAL GAS AND LIQUID PROPANE GAS

Meet or exceed ASHRAE 90.1b (current standard) C.E.C. Listed  
76% Recovery Efficiency

Model Number	Capacity						Recovery* 90°F Rise				A Floor to Top of Heater	B Jacket Dia.	C Vent Size	D Floor to T&P Conn.	E Floor to Gas Conn.	F Floor to Cold Water Conn.	G Floor to Hot Water Conn.	Approx. Shipping Weight
	U.S. Gal.	Imp. Gal.	Nat. BTU/Hr. Input	LP BTU/Hr. Input	1st Hour Rating* (Gal.)	Energy Factor	Nat. U.S. GPH	Nat. U.S. GPH	LP U.S. GPH	LP U.S. GPH	in.	in.	in.	in.	in.	in.	in.	in.
RG2DVMH30T6X	30	27	30,000	30,000	52	0.63	32	27	32	27	57 9/16	18	3	50 1/4	13 3/4	22 1/2	57 1/2	115
RG2DVMH40T6X	40	33	30,000	30,000	59	0.62	32	27	32	27	57 1/4	20	3	50 1/2	13 3/4	22 1/2	58	133

Model Number	Capacity						Recovery* 50°C Rise				A Floor to Top of Heater	B Jacket Dia.	C Vent Size	D Floor to T&P Conn.	E Floor to Gas Conn.	F Floor to Cold Water Conn.	G Floor to Hot Water Conn.	Approx. Shipping Weight
	Liters	Liters	Nat. kW Input	LP kW Input	1st Hour Rating* (Liters)	Energy Factor	Nat. Liters/Hour	Nat. Liters/Hour	LP Liters/Hour	LP Liters/Hour	mm.	mm.	mm.	mm.	mm.	mm.	mm.	mm.
RG2DVMH30T6X	114	114	8.8	8.8	197	0.63	121	121	121	121	1462	457	76	1276	349	572	1461	52
RG2DVMH40T6X	151	151	8.8	8.8	223	0.62	121	121	121	121	1454	508	76	1283	349	572	1473	60

To order Natural Gas heaters change "X" to "N". For 10 year models, change suffix from "6" to "10".

\* Based on manufacturer's rated recovery efficiency.

Energy Factor and First Hour Rating is based on the latest AHRI directory listings.

Optional Roof Jack Kits			
Part Number	A	B	Through The Roof Clearance
239-37022-01	15"	16"-33"	12"
239-37022-02	33 1/2"	33 1/2"-66"	18" / 32"
239-37022-03	32 1/2"-62 1/2"	37 1/2"-74"	32" / 60"
239-37022-04	50"-98 1/2"	54 1/2"-109 1/2"	48" / 90"

(Includes: roof jack, hardware, air intake, instructions).

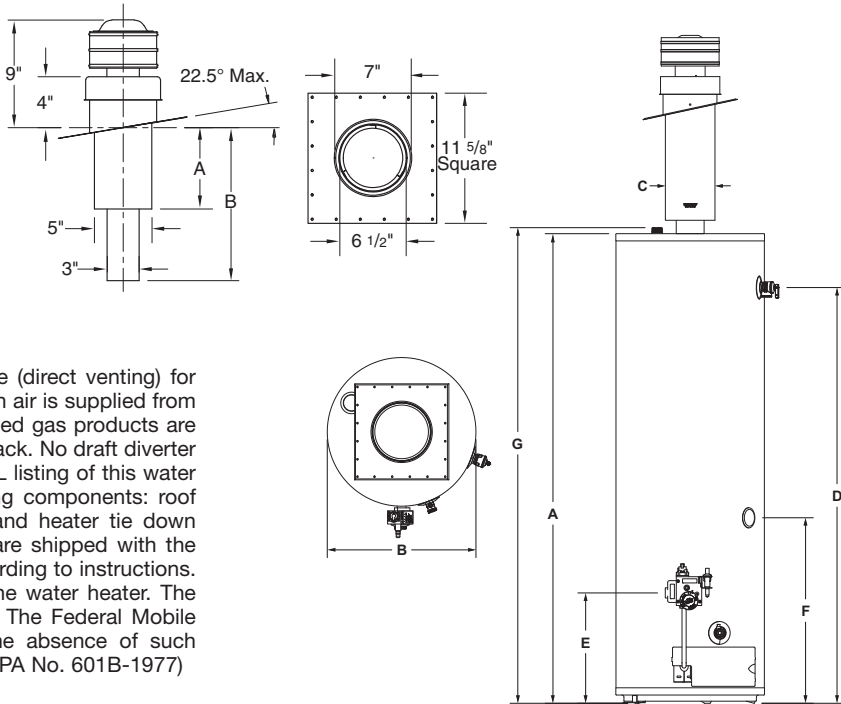

This water heater is of the closed combustion type (direct venting) for mobile home applications only, where all combustion air is supplied from the outdoors through the air intake and all combusted gas products are vented directly to the outside by means of the roof jack. No draft diverter (vent hood) is required for this water heater. The ETL listing of this water heater includes the field installation of the following components: roof jack, roof jack clamp, air intake, air intake seal, and heater tie down materials. These components for field installation are shipped with the heater in a separate box and must be installed according to instructions. No other components are approved for use with the water heater. The water heater must be installed in accordance with The Federal Mobile Home Construction and Safety Standard or in the absence of such standard, The Standard for Mobile Homes (ANSI/NFPA No. 601B-1977)

### General:

All gas water heaters are certified at 300 PSI (2068 kPa) test pressure and 150 PSI (1034 kPa) working pressure.

All water connections are 3/4" NPT (19mm), all gas connections are 1/2" (13mm).

All models design-certified by CSA International (formerly AGA/CGA), ANSI Z-21.10.1 and peak performance rated.

Designed in accordance with the H.U.D. Manufactured Home Construction and Safety Standard, Title 24 CFR, Part 3280.707 (d)(2) for energy efficiency.

**Dimensions and specifications subject to change without notice in accordance with our policy of continuous product improvement.**

### Suitable for Water (Potable) Heating and Space Heating.

Toxic chemicals, such as those used for boiler treatment, shall NEVER be introduced into this system. This unit may NEVER be connected to any existing heating system or component(s) previously used with a non-potable water heating appliance.



Ambler, PA

For U.S. and Canada field service, contact your professional installer or local Bradford White sales representative.

Sales 800-523-2931 • Fax 215-641-1670 / Technical Support 800-334-3393 • Fax 269-795-1089 • Warranty 800-531-2111 • Fax 269-795-1089

International: Telephone 215-641-9400 • Telefax 215-641-9750 / [www.bradfordwhite.com](http://www.bradfordwhite.com)

**BRADFORD WHITE-CANADA** INC. Sales / Technical Support 866-690-0961 / 905-238-0100 • Fax 905-238-0105 / [www.bradfordwhite.com](http://www.bradfordwhite.com)

**Built to be the Best™**

©2015, Bradford White Corporation. All rights reserved.