

**SPECIFICATION SUBMITTAL SHEET**



**FEATURES**

Sizes:  3/4"  1"  1 1/4"  1 1/2"  2"

Maximum working water pressure 175 PSI  
 Maximum working water temperature 180°F  
 Hydrostatic test pressure 350 PSI  
 End connections Threaded ANSI B1.20.1

**OPTIONS**

(Suffixes can be combined)

- L - less ball valves
- FT - with "Fast Test" test cocks
- U - with union ball valves
- S - with bronze "Y" type strainer

**ACCESSORIES**

- Repair kit (rubber only)
- Thermal expansion tank (Model WXTP)
- Bronze wye strainer
- Stainless steel ball valve handles
- QT-SET Quick Test Fitting Set
- Test Cock Lock (Model TCL24)

**APPLICATION**

Designed for installation on potable water lines to protect against both backsiphonage and backpressure of polluted water into the potable water supply. A tethered test cock cap is provided to protect against fouling caused by insects, dirt and debris. Assembly shall provide protection where a potential non-health hazard exists.

**STANDARDS COMPLIANCE**

(Unless otherwise noted, applies to 3/4" thru 2" Horizontal)

- ASSE® Listed 1015 (Vertical flow-up: 1 1/4" thru 2")
- IAPMO® Listed
- AWWA Compliant C510
- CSA® Certified (Vertical flow-up: 1 1/2" & 2")
- NYC MEA 426-89-M VOL 3
- Approved by the Foundation for Cross Connection Control and Hydraulic Research at the University of Southern California

**MATERIALS**

Main valve body Cast Bronze ASTM B 584  
 Access covers Cast Bronze ASTM B 584  
 Fasteners Stainless Steel, 300 Series  
 Elastomers Silicone (FDA approved)  
 Buna Nitrile (FDA approved)  
 Polymers Noryl™, NSF Listed  
 Springs Stainless steel, 300 series  
 Test cock cover Plastic

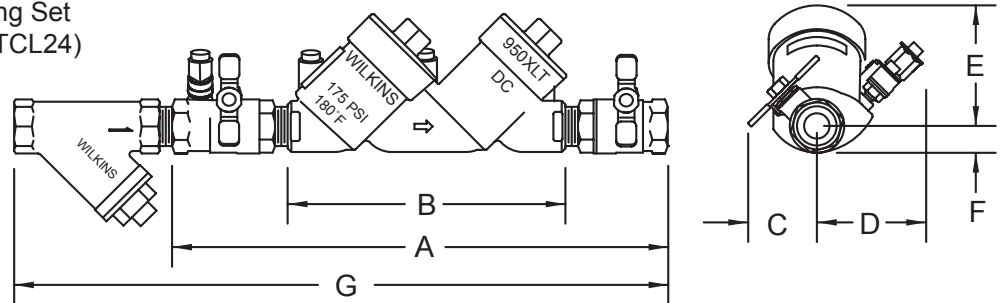

**DIMENSIONS & WEIGHTS (do not include pkg.)**

MODEL SIZE	DIMENSIONS (approximate)																WEIGHT				
	A		A UNION BALL VALVES		B LESS BALL VALVES		C		D		E		F		G		LESS BALL VALVES		WITH BALL VALVES		
	in.	mm	in.	mm	in.	mm	in.	mm	in.	mm	in.	mm	in.	mm	in.	mm	lbs.	kg	lbs.	kg	
3/4	20	13	330	14 5/16	364	8 3/4	222	2 3/8	60	2 5/16	59	3 5/16	84	3/4	19	17 5/8	448	4	1.8	6	2.7
1	25	14	356	15 3/4	400	8 3/4	222	2 1/2	64	2 5/16	59	3 5/16	84	3/4	19	19 3/4	502	8	3.6	12	5.4
1 1/4	32	19 5/8	499	21 5/8	549	13 3/4	349	4	102	3 5/8	92	4 3/8	111	1 5/16	33	24 3/4	629	16	7.3	22	10
1 1/2	40	20 5/16	516	22 5/16	567	13 3/4	349	5 3/8	137	3 5/8	92	4 3/8	111	1 5/16	33	25 15/16	659	16	7.3	22	10
2	50	21 3/8	543	23 1/4	591	13 3/4	349	5 13/16	148	3 5/8	92	4 3/8	111	1 5/16	33	28 5/16	719	17	7.7	29	13.2

## FLOW CHARACTERISTICS

### MODEL 950XLT 3/4", 1", 1 1/4", 1 1/2" & 2" (STANDARD & METRIC)

FLOW RATES (l/s)

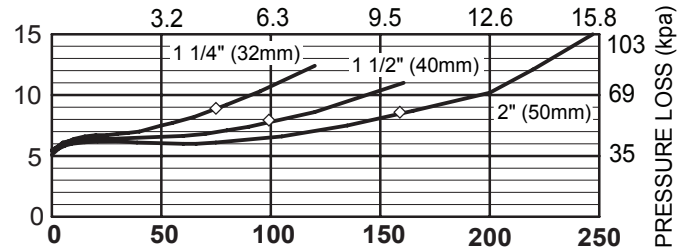
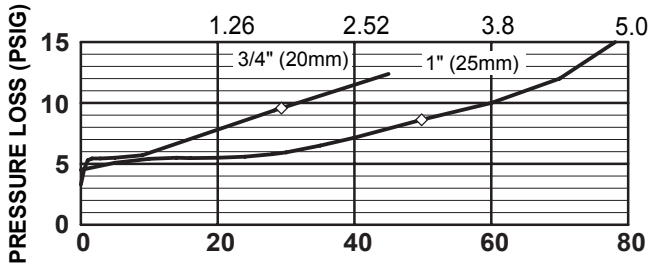

FLOW RATES (GPM)

◇ Rated Flow (Established by approval agencies)

### TYPICAL INSTALLATION

Local codes shall govern installation requirements. To be installed in accordance with the manufacturer's instructions and the latest edition of the Uniform Plumbing Code. Unless otherwise specified, the assembly shall be mounted at a minimum of 12" (305mm) and a maximum of 30" (762mm) above adequate drains with sufficient side clearance for testing and maintenance. If installed below grade, be certain adequate drainage is provided to prevent the device from being submerged.

Capacity thru Schedule 40 Pipe				
Pipe size	5 ft/sec	7.5 ft/sec	10 ft/sec	15 ft/sec
1/8"	1	1	2	3
1/4"	2	2	3	5
3/8"	3	4	6	9
1/2"	5	7	9	14
3/4"	8	12	17	25
1"	13	20	27	40
1 1/4"	23	35	47	70
1 1/2"	32	48	63	95
2"	52	78	105	167

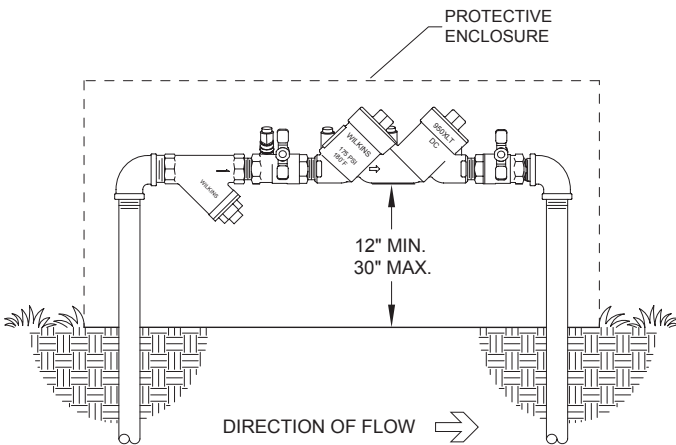

OUTDOOR INSTALLATION

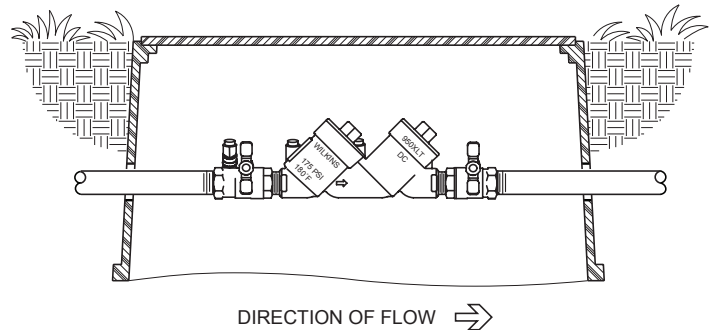

PIT INSTALLATION

### SPECIFICATIONS

The Double Check Type Backflow Preventer shall be ASSE Listed 1015, rated to 180°F and supplied with full port ball valves. The main body and access covers shall be bronze (ASTM B 584), the seat ring and all internal polymers shall be NSF® Listed Noryl™ and the seat disc elastomers shall be SILICONE. The first and second check shall be located at a 45° angle and accessible for maintenance from the top of the device, without removing the device from the line. Each check shall have separate access covers and test cocks shall be accessible from the top of the device. Test cocks shall be protected from debris by a tethered cap. The Double Check Type Backflow Preventer shall be a WILKINS Model 950XLT.