

320725-756
320725-757
320725-758

Fixed Speed Inducer Assembly Kit

Installation Instructions

NOTE: Read the entire instruction manual before starting the installation.

SAFETY CONSIDERATIONS

Improper installation, adjustment, alteration, service, maintenance, or use can cause explosion, fire, electrical shock, or other conditions which may cause death, personal injury, or property damage. Consult a qualified installer, service agency, or your distributor or branch for information or assistance. The qualified installer or agency must use factory-authorized kits or accessories when modifying this product. Refer to the individual instructions packaged with the kits or accessories when installing.

Follow all safety codes. Wear safety glasses, protective clothing, and work gloves. Have a fire extinguisher available. Read these instructions thoroughly and follow all warnings or cautions include in literature and attached to the unit. Consult local building codes, the current editions of the National Fuel Gas Code (NFGC) NFPA 54/ANSI Z223.1 and the National Electrical Code (NEC) NFPA 70.

In Canada, refer to the current editions of the National Standards of Canada CAN/CGA-B149.1 and .2 Natural Gas and Propane Installation Codes, and Canadian Electrical Code CSA C22.1

Recognize safety information. This is the safety-alert symbol . When you see this symbol on the unit and in instructions or manuals, be alert to the potential for personal injury.

Understand the signal words **DANGER**, **WARNING**, and **CAUTION**. These words are used with the safety-alert symbol. **DANGER** identifies the most serious hazards which **will** result in severe personal injury or death. **WARNING** signifies hazards which **could** result in personal injury or death. **CAUTION** is used to identify unsafe practices which **may** result in minor personal injury or product and property damage. **NOTE** is used to highlight suggestions which **will** result in enhanced installation, reliability, or operation.

WARNING

FIRE, EXPLOSION, ELECTRICAL SHOCK HAZARD

Failure to follow this warning could result in personal injury, death and/or property damage.

Before installing or servicing unit, always turn off main electrical and gas to unit. Lockout and tag with appropriate warning label. There may be more than one disconnect switch.

CAUTION

CUT HAZARD

Failure to follow this caution may result in personal injury.

Sheet metal parts may have sharp edges or burrs. Use care and wear appropriate protective clothing, safety glasses and gloves when handling parts and servicing furnaces.

CAUTION

UNIT DAMAGE HAZARD

Failure to follow this caution may result in improper and dangerous operation.

Label all wires prior to disconnection when servicing controls.

INTRODUCTION

This instruction covers installation of the high output permanent split capacitor (PSC) inducer motor kit on models 340MAV, 340AAV, 345MAV, 350MAV, 350AAV, 351DAS, 353AAV, 490AAV, 58MCA, 58MCB, 58MEB, 58MSA, 58MXA, 58MXB, PG9MAA and PG9MAB Condensing Gas Furnaces. See Table 1 for kit applicability.

DESCRIPTION AND USAGE

Use this PSC inducer motor kit to replace a failed inducer motor assembly.

This kit contains the following items:

Inducer assembly	1
Installation Instructions	1

NOTE: Inducer assembly consists of motor and fan, capacitor, wheel, motor mount, inducer cover, inducer housing, vent cap, and vent clamp.

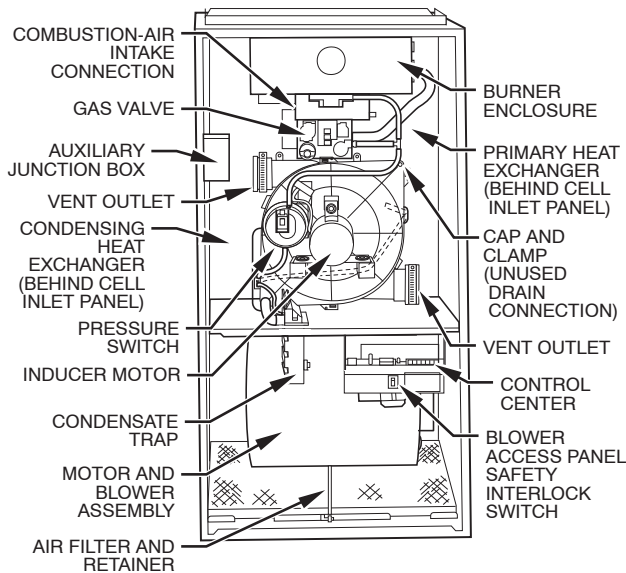

A98401

Fig. 1 - Inducer Motor Assembly in Upflow Furnace Orientation

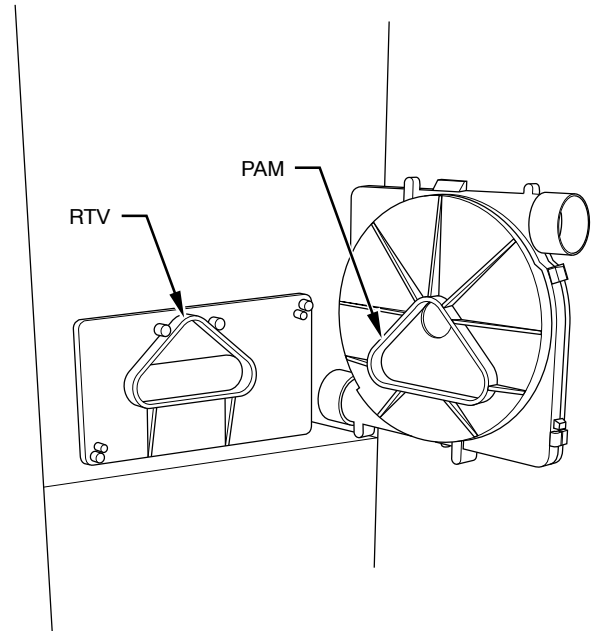

A93081

Fig. 2 - Inducer Housing to Collector Box Gasket

INSTALLATION

Step 1 — Remove Old Motor Assembly

1. Turn off gas and electrical supplies to unit.
2. Remove main furnace door.
3. Remove drain tube from inducer motor mounting cover plate.
4. Remove pressure switch tubes. (See Fig. 1.)
 - a. Remove tube attached to pressure switch from collector box.
 - b. Remove tube attached to pressure switch from burner enclosure and gas valve.
5. Remove screw securing pressure switch and capacitor to inducer housing.
6. Disconnect motor lead connector at quick-connect.
7. Disconnect vent pipe from inducer housing by loosening coupling clamp on inducer outlet. If coupling has 2 clamps, loosen clamp on vent pipe side. Move pipe out of furnace casing.
8. Using backup wrench, disconnect gas supply pipe from gas valve.
9. Remove wires from gas valve. Note location for reassembly.
10. Remove burner enclosure cover.
11. Remove screws securing manifold to burner enclosure.
12. Remove manifold, orifices, and gas valve as 1 assembly.
13. Remove 4 bolts attaching inducer housing assembly to heat exchanger cell panel.

Step 2 — Install New Motor Assembly

1. Inspect seal on collector box. (See Fig. 2.)

NOTE: If collector box seal is damaged in any way, it must be repaired. To repair, apply sealant releasing agent such as PAM cooking spray or equivalent (must not contain corn or canola oil,

halogenated hydrocarbons or aromatic contents to prevent inadequate sealing) to inducer housing. Apply a small bead of G.E. RTV 162, G.E. 6702, or Dow-Corning RTV 738 sealant to groove in collector box. G.E. 162 (P771-9003) is available through RCD in 3-oz. tubes.

2. Remove 4 bolts and spacers from old inducer housing assembly.
3. Install spacers in new inducer housing.
4. Insert bolts through inducer housing.

NOTE: Inserting bolts at this time will add to the ease of their installation later.

5. Install new inducer housing assembly to heat exchanger cell panel by aligning guide pins in collector box.

NOTE: Do not pinch collector box pressure tube when assembling inducer housing to collector box.

6. Tighten 4 bolts securing inducer housing assembly to heat exchanger cell panel.
7. Remove screw securing capacitor and reuse to secure pressure switch and capacitor to inducer motor mounting cover plate.
8. Reconnect pressure switch tubes. See tubing label on furnace for proper connections.
 - a. Connect tube from burner enclosure and gas valve to pressure switch.
 - b. Connect tube from collector box to pressure switch.
9. Reconnect motor leads to quick-connect.
10. Reconnect drain tube to inducer motor mounting cover plate.
11. Remove cap and clamp from unused drain connection on old inducer motor mounting cover plate and install on new inducer motor mounting cover plate.
12. Connect vent pipe by inserting pipe through elastomeric (rubber) coupling and then fully into inducer housing outlet. Tighten coupling clamp screw(s) to 15 in.-lb of torque.

⚠ WARNING

CARBON MONOXIDE POISONING AND PROPERTY DAMAGE HAZARD

Failure to follow this warning could result in personal injury, death and/or property damage.

After completing installation, vent pipe must be installed and fully seated against inducer housing internal stop. Coupling clamp screw(s) must be tightened to 15 in.-lb of torque to prevent disassembly of vent from furnace, and to prevent vent gas and condensate leakage.

13. Reinstall manifold assembly with gas valve to burner box. Replace mounting screws.
14. Replace burner box cover.
15. Using a back-up wrench to prevent rotation and improper orientation, reconnect gas supply pipe to gas valve.

16. Reconnect wires to gas valve. Refer to furnace wiring diagram for proper wire location.
17. Turn on gas and electrical supplies to unit.
18. Check for gas leaks.

⚠ WARNING

FIRE AND EXPLOSION HAZARD

Failure to follow this warning could result in personal injury, death and/or property damage.

Never check for gas leaks with an open flame. Use a commercially available soap solution made specifically for the detection of leaks to check all connections.

19. Check furnace operation through 2 complete cycles.
20. Reinstall main furnace door.

320725

Table 1 – Kit Applicability

Fixed Speed Condensing Furnace Inducer Kits								
Kit Part Number	340AAV 340MAV	350AAV 350MAV 353AAV	345MAV	351DAS	58MCA 58MCB	58MEB 58MXA 58MXB	58MSA	PG9MAA PG9MAB 490AAV
320725-756	024040 036040	024040 036040	024040 036040	-----	040-08 040-12	040-08 040-12	040-08 040-12	024040 036040
320725-756	024060 036060 048060	024060 036060 048060	024060 036060 048060	-----	060-08 060-12 060-16	060-08 060-12 060-16	060-08 060-12 060-16	024060 036060 048060
320725-756	036080 048080 060080	036080 048080 060080	036080 048080 060080	036080 048080 060080	080-12 080-16 080-20	080-12 080-16 080-20	080-12 080-16 080-20	036080 048080 060080
320725-756	048100 060100	048100 060100	048100 060100		100-16 100-20	100-16 100-20	100-16 100-20	048100 060100
320725-757	060120	060120	060120		120-20	120-20	120-20	060120
320725-758	060140	060140	060140		140-20	140-20	140-20	060140

320725