

# Hydronic Product & Application Catalog

**FlatPlate**<sup>®</sup>  
by GEA PHE Systems North America

THE brazed plate heat exchanger guide for these applications:

- Domestic Hot Water
- Double Wall Domestic Hot Water
- Radiant Floor Heating
- Swimming Pools and Spas
- Snow Melt Systems
- Liquid-to-Liquid General Purpose Selections
- Steam-to-Liquid General Purpose Selections
- Replacing a Shell-and-Tube Heat Exchanger
- Accessories to make your life easier
- Replacing Other Brands of Brazed Plate Heat Exchangers



## Brazed Plate Heat Exchangers



# Index of Applications

Application	Page
Domestic Hot Water	4
Domestic Hot Water Double Wall	6
Radiant Floor Heating	8
Snow Melt Systems	10
Liquid-to-Liquid General Purpose Selections	12
Steam-to-Liquid General Purpose Selections	14
Swimming Pools and Spas	16
Large Capacity/Low Pressure Drop	21
Replacing a Shell-and-Tube Heat Exchanger	22
Replacing Other Brands of Brazed Plate Heat Exchangers	24
Product Dimensions	25
Accessories to make your life easier	26
Conversion Formulas	27
Standard Selling Terms & Conditions	28

## FlatPlateSelect Free Online Selection Software

### Application

Although the selections in this catalog cover the common design situations, there may be times when you have a less common design, or you may need submittal sheets. All of this is available at [www.flatplateselect.com](http://www.flatplateselect.com).

### The FlatPlateSelect Advantage.

- Easy to use. No training needed.
- Free. No Fees. Just sign in and use it.
- Flexible. Save your selections, print them and come back later to modify them.
- Accessible. Always on, 24/7.



Start Using It Today At:

***[www.flatplateselect.com](http://www.flatplateselect.com)***

To find a wholesaler near you  
**Call 800-774-0474**  
Ask for Brazed Technical Support

To run your own detailed selection  
**[www.flatplateselect.com](http://www.flatplateselect.com)**



To find out more about FlatPlate®  
**[www.flatplate.com](http://www.flatplate.com)**

# Hydronic Heat Exchangers

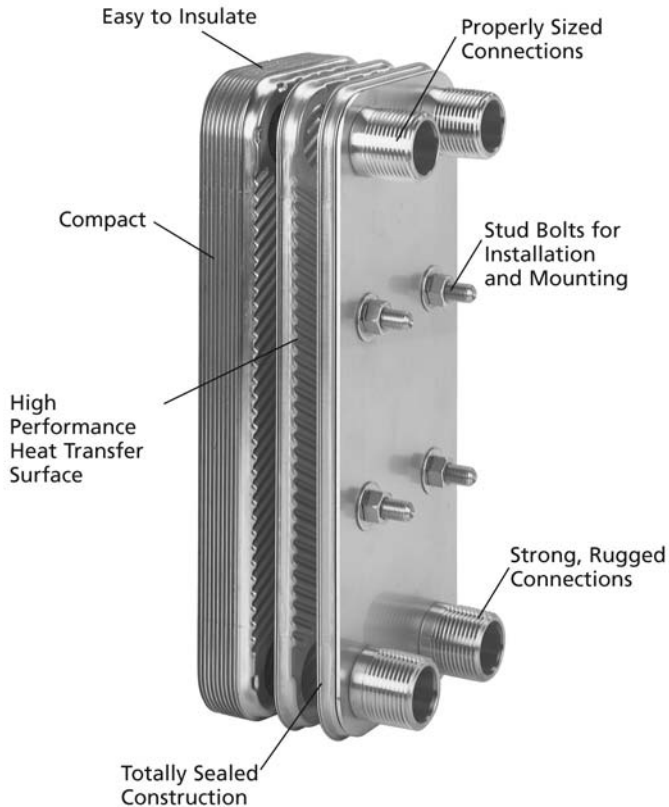

## Simply Effective

FlatPlate® brazed plate heat exchangers consist of 4 to 300 specially formed stainless steel plates, which are then brazed together in a vacuum furnace for leak-tight, rugged construction.

When stacked the plates form two separate flow passages between the plates, thus allowing a liquid to flow between every other plate.

This provides heat transfer and complete separation of the two media.

With FlatPlate's high performance heat transfer surface, a very compact, cost effective design is the result.

## Easy To Select

- Refer to the pages that follow for the full range of operating conditions.
- For more detailed operating conditions, go to [www.flatplateselect.com](http://www.flatplateselect.com).

## Easy To Install

- Mounting Studs allow the use of mounting brackets to hold the unit in place while you pipe it up.
- Compact size means it fits easily into confined spaces, especially when replacing a much larger shell-and-tube heat exchanger.
- Insulation is a snap with our tools-free insulation kits.

## High Performance

- High turbulence created by corrugations in the plates result in closer approach temperatures with much smaller units.
- Fully brazed construction handles high operating pressures.
- Choice of brazing materials (copper or nickel-chrome) broadens the range of media possible.
- Choice of plate material (316L Stainless or Marine Grade Stainless) means you can pick the right heat exchanger for your application, not a "good enough" heat exchanger.

## Proven and Reliable

- Easily complies with requirements of UL, CE and ASME Section VIII (UM-Stamp).
- CRN (Canadian Registration Number) optional.
- Every heat exchanger is tested before it leaves our plant.

'FlatPlate' is a Registered Trademark of GEA Group.

To find a wholesaler near you  
**Call 800-774-0474**  
Ask for Brazed Technical Support

To run your own detailed selection  
[www.flatplateselect.com](http://www.flatplateselect.com)



To find out more about FlatPlate®  
[www.flatplate.com](http://www.flatplate.com)

# Domestic Hot Water (FG models)

## Application

Used in boiler applications to isolate the boiler water from the potable hot water, these offer quicker response and smaller size.

## Selection

### Step One

- Make sure your design conditions match the design conditions for this chart.
- Find the Capacity (BTUH) you need.

### Step Two

- Select the appropriate FlatPlate heat exchanger.

### Step Three

- Check your selection to make sure that the minimum required flow rate and pressure drop are acceptable.

### Step Four

- Contact your FlatPlate wholesaler to obtain the heat exchanger.

### Selection Notes:

- Select your pump(s) based on the minimum recommended flow rates shown on the table at right.
- For instantaneous hot water heating, the same heat exchanger selection applies but no minimum flow is required.

## Design Conditions

- Boiler: 180°F Supply, 150°F Return
- Domestic: 50°F Return, 140°F Supply
- This table is based on a 50°F to 140°F standard temperature rise, and the minimum flow rates are 1.5 times the corresponding flow of this temperature rise, to maximize BTUH output and minimize scaling.

Capacity (BTUH)	Model and Size FG = FG model 5X12 = Nominal Size -12 = Plate Count (3/4" MPT) = Connection	Side A (Domestic)		Side B (Boiler)	
		Minimum Required Flow Rate (GPM)	Pressure Drop (PSI) at the Min. Flow Rate	Minimum Required Flow Rate (GPM)	Pressure Drop (PSI) at the Min. Flow Rate
18,000	FG5X12-4 (3/4" MPT)	0.4	0.7	1.2	1.1
30,000	FG5X12-4 (3/4" MPT)	0.6	1.4	2.0	2.8
40,000	FG5X12-4 (3/4" MPT)	0.8	2.4	2.7	4.8
50,000	FG5X12-6 (3/4" MPT)	1.1	1.1	3.4	3.4
60,000	FG5X12-6 (3/4" MPT)	1.3	1.4	4.0	4.8
70,000	FG5X12-8 (3/4" MPT)	1.5	1.0	4.7	3.7
80,000	FG5X12-8 (3/4" MPT)	1.7	1.3	5.4	4.8
90,000	FG5X12-10 (3/4" MPT)	2.0	1.0	6.1	3.9
100,000	FG5X12-10 (3/4" MPT)	2.2	1.2	6.8	4.8
125,000	FG5X12-12 (3/4" MPT)	2.7	1.2	8.5	5.2
150,000	FG5X12-14 (3/4" MPT)	3.3	1.2	10.2	5.4
175,000	FG5X12-16 (3/4" MPT)	3.9	1.2	11.9	5.7
200,000	FG5X12-20 (1" MPT)	4.4	1.0	13.6	4.8
250,000	FG5X12-24 (1" MPT)	5.5	1.0	17.0	5.2
300,000	FG5X12-24 (1" MPT)	6.7	1.3	20.4	7.3
350,000	FG5X12-24 (1" MPT)	7.8	1.6	23.8	9.7
400,000	FG5X12-30 (1" MPT)	8.9	1.5	27.2	8.3
450,000	FG5X12-36 (1" MPT)	10.0	1.3	30.6	7.5
500,000	FG5X12-36 (1" MPT)	11.1	1.4	34.1	9.1
600,000	FG5X12-40 (1-1/4" MPT)	13.4	1.6	40.9	10.6
700,000	FG5X12-50 (1-1/4" MPT)	15.6	1.5	47.7	9.8
	FG10X20L-20 (1-1/2" MPT)	15.6	0.5	47.7	4.5
800,000	FG5X12-60 (1-1/4" MPT)	17.8	1.5	54.5	9.5
900,000	FG5X12-70 (1-1/4" MPT)	20.1	1.5	61.3	9.6
	FG10X20L-24 (1-1/2" MPT)	20.1	0.6	61.4	0.5
1,000,000	FG5X12-80 (1-1/4" MPT)	22.3	1.5	68.2	10.0
	FG10X20L-30 (2" MPT)	22.3	0.5	68.2	0.4
1,250,000	FG10X20L-30 (2" MPT)	27.9	0.7	85.2	6.1
1,500,000	FG10X20L-40 (2-1/2" MPT)	33.5	0.6	102.2	5.2
1,750,000	FG10X20L-50 (2-1/2" MPT)	39.1	0.6	119.3	4.8
2,000,000	FG10X20L-50 (2-1/2" MPT)	44.6	0.7	136.3	6.2
2,250,000	FG10X20L-60 (2-1/2" MPT)	50.2	0.7	153.4	5.9
2,500,000	FG10X20L-70 (2-1/2" MPT)	55.8	0.7	170.4	5.8
2,750,000	FG10X20L-80 (2-1/2" MPT)	61.4	0.7	187.5	5.9
3,000,000	FG10X20L-80 (2-1/2" MPT)	67.0	0.8	204.5	7.0

To find a wholesaler near you

**Call 800-774-0474**

Ask for Brazed Technical Support

To run your own detailed selection

**www.flatplateselect.com**



To find out more about FlatPlate®

**www.flatplate.com**

# Domestic Hot Water (FG models)

## Piping Notes

Two types of piping installations are typical:

- **Recirc to Tank only:** In most residential and light commercial applications, a re-circ pump to the hot water tank is typical.
- **Instantaneous:** In a few installations, instantaneous hot water heating can be used.

### Piping

- Tee(s) on the output side of the heat exchanger are recommended for convenience in the event that future chemical descaling and cleaning is required.

### Controls

- Typical control of the pumps (Recirc to Tank only) should use an aqua stat in the hot water storage tank to maintain set point temperature (e.g. 130°F).

### Controls for Re-Circ

- For re-circulated domestic hot water systems (e.g. apartments, hospitals, factories and office buildings), a motorized three-way mixing valve is required on the boiler side, to be modulated based on leaving water temperature leaving the heat exchanger into the domestic water loop.
- The hot water loop pump runs continuously. This maintains the hot water set point for the loop and storage tank.
- The re-circ pump should flow 100% of the return loop water through the heat exchanger, then to the storage tank (if required, depending on boiler capacity) at all times to minimize scaling and maximize BTUH output.
- City water inlet is recommended before the heat exchanger and after the pump, to maximize the heat exchanger capacity.

### Controls for Instantaneous Water Heating:

- A three-way tempering valve is required, as well as an anti-scalding safety device.
- The boiler pump should run continuously.

### Controls for Instantaneous Steam Systems:

- A modulating steam valve and proper steam trapping is required.

### Start-up:

- The bypass/balancing valve should be adjusted at full load to obtain the proper return water temperature to the boiler.
- For applications with a recirc domestic hot water loop, the modulating three-way valve should be adjusted so that it maintains proper domestic water temperature, and does not hunt or overshoot.
- Slow to Medium response rate is recommended.

## Recirc - to - Tank

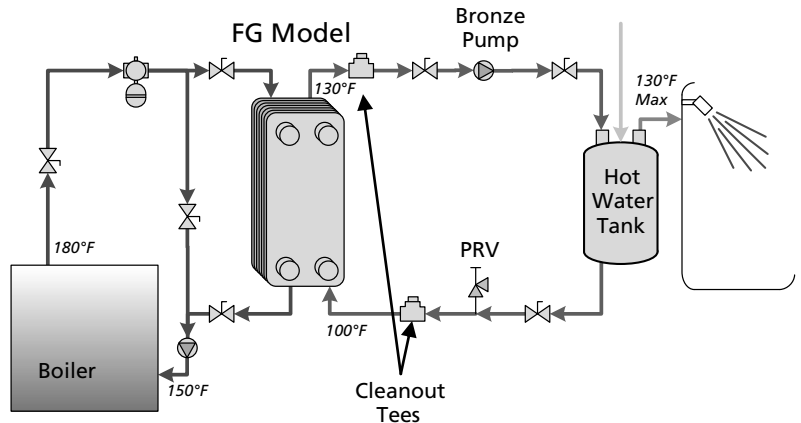

## Recirc - to - Building Loop

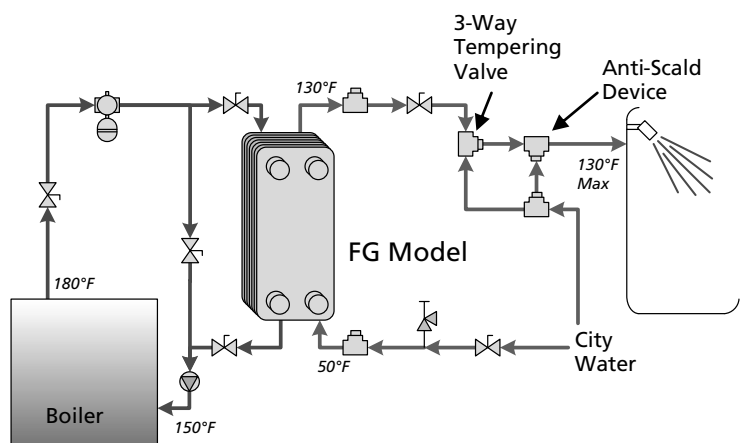

To find a wholesaler near you  
**Call 800-774-0474**  
 Ask for Brazed Technical Support

To run your own detailed selection  
[www.flatplateselect.com](http://www.flatplateselect.com)



To find out more about FlatPlate®  
[www.flatplate.com](http://www.flatplate.com)

# Domestic Hot Water Double Wall (DW models)

## Application

Provides double separation of potable water from boiler water or other non-potable heating fluids, to meet local and state plumbing codes.

- This is a “true” double wall vented design, with double wall plates and double seal fluid ports, both of which have positive leak detection.
- Full thickness 316L copper brazed plates for longer life and reliability.
- Quicker response on a heating call and smaller size than older technologies.
- Design Pressure is 450 psig.
- Mounting Studs are included as standard.
- ASME Code Stamp is available on request.

## Selection

### Step One

- Make sure your design conditions match the design conditions for this chart. If they don't, contact your local FlatPlate® representative.
- Find the Capacity (BTUH) you need.

### Step Two

- Select the appropriate FlatPlate heat exchanger.

### Step Three

- Check your selection to make sure that the minimum required flow rate and pressure drop are acceptable.

### Step Four

- Contact your FlatPlate wholesaler to obtain the heat exchanger.

## Selection Notes:

- Select your pump(s) based on the minimum recommended flow rates shown on the table at right.
- For instantaneous hot water heating, the same heat exchanger selection applies but no minimum flow



Every FlatPlate heat exchanger is equipped with mounting studs, for easier, faster installation with our mounting bracket. **Find the right size bracket on page 26.**

Boiler: 180°F Supply, 150°F Return Domestic: 50°F Return, 140°F Supply					
This table is based on a 50°F to 140°F standard temperature rise, and the minimum flow rates are 1.5 times the corresponding flow of this temperature rise, to maximize BTUH output and minimize scaling.					
Capacity (BTUH)	Model and Size DW = Model 5X12 = Nominal Size -10 = Plate Count (1" MPT) = Connection	Side B (Boiler)		Side A (Domestic)	
		Minimum Required Flow Rate (GPM)	Pressure Drop (PSI) at the Min. Flow Rate	Minimum Required Flow Rate (GPM)	Pressure Drop (PSI) at the Min. Flow Rate
75,000	DW5X12-10 (1" MPT)	7.7	6.2	1.7	0.3
150,000	DW5X12-20 (1" MPT)	15.4	7.6	3.4	0.4
200,000	DW5X12-30 (1" MPT)	20.5	5.8	4.5	0.3
300,000	DW5X12-40 (1" MPT)	30.7	7.2	6.7	0.4
350,000	DW5X12-50 (1-1/4" MPT)	35.8	6.4	7.8	0.4
400,000	DW5X12-60 (1-1/4" MPT)	41.0	6.0	8.9	0.3
500,000	DW5X12-70 (1-1/4" MPT)	51.2	7.2	11.2	0.4
600,000	DW5X12-90 (1-1/4" MPT)	61.4	7.0	13.4	0.4
	DW10X20-94 (2" MPT)	61.4	6.8	13.4	0.4
700,000	DW5X12-110 (1-1/4" MPT)	71.7	7.3	15.6	0.4
	DW10X20-110 (2" MPT)	71.7	6.8	15.6	0.4
800,000	DW10X20-134 (2" MPT)	81.9	6.1	17.9	0.4
900,000	DW10X20-134 (2" MPT)	92.2	7.7	20.1	0.5
1,000,000	DW10X20-154 (2" MPT)	102.4	7.3	22.3	0.4

<p>To find a wholesaler near you <b>Call 800-774-0474</b> Ask for Brazed Technical Support</p>	<p>To run your own detailed selection <b>www.flatplateselect.com</b></p>	 <p>To find out more about FlatPlate® <b>www.flatplate.com</b></p>
--	--	--

# Domestic Hot Water Double Wall (DW models)

## Piping Notes

### Piping

- Tee(s) on the output side of the heat exchanger are recommended for convenience in the event that future chemical descaling and cleaning is required.

### Controls

- Typical control of the pumps (Recirc to Tank only) should use an aqua stat in the hot water storage tank to maintain set point temperature (e.g. 130°F).

### Controls for Re-Circ

- For re-circulated domestic hot water systems (e.g. apartments, hospitals, factories and office buildings), a motorized three-way mixing valve is required on the boiler side, to be modulated based on leaving water temperature leaving the heat exchanger into the domestic water loop.
- The hot water loop pump runs continuously. This maintains the hot water set point for the loop and storage tank.
- The re-circ pump should flow 100% of the return loop water through the heat exchanger, then to the storage tank (if required, depending on boiler capacity) at all times to minimize scaling and maximize BTUH output.
- City water inlet is recommended before the heat exchanger and after the pump, to maximize the heat exchanger capacity.

### Controls for Instantaneous Water Heating:

- A three-way tempering valve is required, as well as an anti-scalding safety device.
- The boiler pump should run continuously.

### Controls for Steam Systems:

- A modulating steam valve and proper steam trapping is required.

### Start-up:

- The bypass/balancing valve should be adjusted at full load to obtain the proper return water temperature to the boiler.
- For applications with a recirc domestic hot water loop, the modulating three-way valve should be adjusted so that it maintains proper domestic water temperature, and does not hunt or overshoot.
- Slow to Medium response rate is recommended.

### Recirc - to - Tank

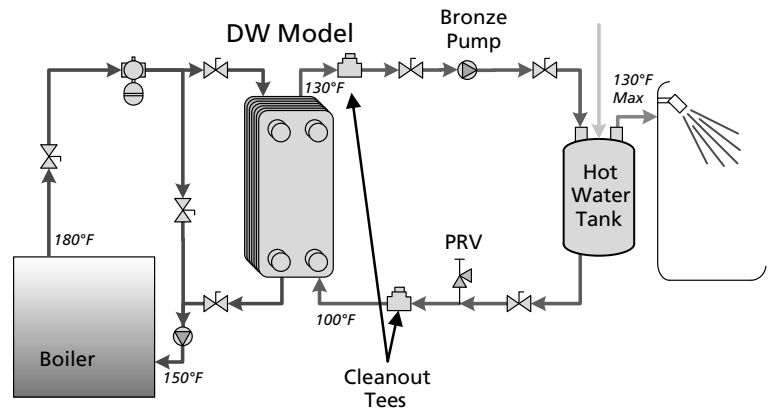

### Recirc - to - Building Loop

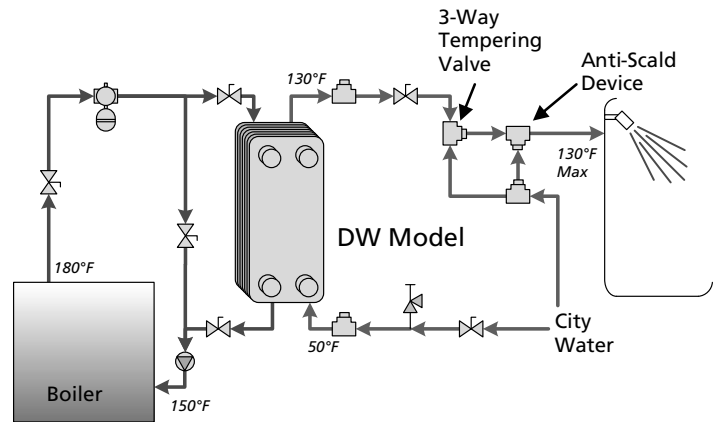

To find a wholesaler near you  
**Call 800-774-0474**  
 Ask for Brazed Technical Support

To run your own detailed selection  
[www.flatplateselect.com](http://www.flatplateselect.com)



To find out more about FlatPlate®  
[www.flatplate.com](http://www.flatplate.com)

# Radiant Floor Heating (FP models)

## Application

Isolates radiant floor loop from the heating loop. Look for this when one or more of these are occurring:

- Radiant floor loop contains glycol blend.
- Heat is provided by a steam boiler or other source where a temperature "step-down" is needed.
- Boiler pressure exceeds the pressure capacity of the radiant loop, requiring pressure "step-down".
- Heating is provided by the domestic hot water heater, and isolation from the potable water is required.

## FlatPlate Advantages

- Full thickness 316L copper brazed plates for longer life and reliability.
- Quicker response on a heating call.
- Smaller size than older technologies, better for retrofit.
- Design Pressure is 300 psig, to handle most system requirements.
- Mounting Studs are included as standard to make mounting as easy as possible.
- ASME Code Stamp is available on request.

## Selection:

### Step One

- Make sure your design conditions match the design conditions for this chart. If not contact your local FlatPlate® Representative or use FlatPlateSelect.
- Find the Capacity (BTUH) you need.

### Step Two

- Select the appropriate FlatPlate heat exchanger.

### Step Three

- Check your selection to make sure that the minimum required flow rate and pressure drop are acceptable.

### Step Four.

- Contact your FlatPlate wholesaler to obtain the heat exchanger.

## Selection Notes:

- Select your pump(s) based on the minimum recommended flow rates shown on the table at right.

Radiant Floor: 120°F Supply, 100°F Return Boiler: 180°F Supply, 160°F Return					
This table is based on a 100°F to 120°F standard temperature rise, and the minimum flow rates are 1.5 times the corresponding flow at this temperature rise, to maximize BTUH output and minimize scaling.					
Capacity (BTUH)	Model and Size FP = Model 5X12L = Nominal Size -6 = Plate Count (3/4" MPT) = Connection	Side A (Boiler)		Side B (Radiant Floor)	
		Minimum Required Flow Rate (GPM)	Pressure Drop (PSI) at the Min. Flow Rate	Minimum Required Flow Rate (GPM)	Pressure Drop (PSI) at the Min. Flow Rate
50,000	FP5X12L-6 (3/4" MPT)	5.0	3.1	5.1	1.5
100,000	FP5X12L-8 (3/4" MPT)	10.2	5.3	10.1	3.2
150,000	FP5X12L-10 (1" MPT)	15.4	6.7	15.1	4.6
200,000	FP5X12L-12 (1" MPT)	20.5	7.6	20.2	5.7
250,000	FP5X12L-16 (1" MPT)	25.6	6.4	25.2	5.2
300,000	FP5X12L-20 (1-1/4" MPT)	30.7	5.8	30.3	5.1
350,000	FP5X12L-20 (1-1/4" MPT)	35.8	7.8	35.3	6.8
400,000	FP5X12L-24 (1-1/4" MPT)	41.0	7.2	40.3	6.5
450,000	FP10X20L-20 (1-1/2" MPT)	46.1	4.2	45.4	3.6
500,000	FP10X20L-20 (1-1/2" MPT)	51.2	5.1	50.2	4.4
600,000	FP10X20L-20 (1-1/2" MPT)	61.4	7.2	60.5	6.2
700,000	FP10X20L-24 (1-1/2" MPT)	71.7	6.7	70.6	6.0
800,000	FP10X20L-30 (2" MPT)	81.9	5.1	80.7	5.2
900,000	FP10X20L-30 (2" MPT)	92.2	7.1	90.8	6.5
1,000,000	FP10X20L-36 (2" MPT)	102.4	6.2	100.9	5.9
1,100,000	FP10X20L-36 (2" MPT)	112.6	7.4	111.0	7.0
1,200,000	FP10X20L-40 (2" MPT)	122.9	7.3	121.0	7.0
1,300,000	FP10X20L-50 (2-1/2" MPT)	133.1	5.9	131.1	5.7
1,400,000	FP10X20L-50 (2-1/2" MPT)	143.4	6.8	141.2	6.6
1,500,000	FP10X20L-50 (2-1/2" MPT)	153.6	7.7	120.0	7.5
1,600,000	FP10X20L-60 (2-1/2" MPT)	163.8	6.7	161.4	6.5
1,700,000	FP10X20L-60 (2-1/2" MPT)	174.1	7.5	171.5	7.3
1,800,000	FP10X20L-70 (2-1/2" MPT)	184.3	6.8	181.6	6.7
1,900,000	FP10X20L-70 (2-1/2" MPT)	194.6	7.5	191.7	7.4
2,000,000	FP10X20L-80 (2-1/2" MPT)	204.8	7.0	201.7	7.0
2,100,000	FP10X20L-80 (2-1/2" MPT)	215.0	7.7	211.8	7.7
2,200,000	FP10X20L-90 (2-1/2" MPT)	225.3	7.4	221.9	7.4
2,300,000	FP10X20L-100 (2-1/2" MPT)	235.5	7.3	232.0	7.2
2,400,000	FP10X20L-100 (2-1/2" MPT)	245.8	7.9	242.1	7.9
2,500,000	FP10X20L-110 (2-1/2" MPT)	256.0	7.8	252.2	7.8



Every FlatPlate heat exchanger is equipped with mounting studs, for easier, faster installation with our mounting bracket. **Find the right size bracket on page 26.**

To find a wholesaler near you  
**Call 800-774-0474**  
Ask for Brazed Technical Support

To run your own detailed selection  
[www.flatplateselect.com](http://www.flatplateselect.com)



To find out more about FlatPlate®  
[www.flatplate.com](http://www.flatplate.com)



# Radiant Floor Heating (FP models)

## Installation and Startup Notes:

- **Piping:** Follow standard piping practices recommended by the radiant floor system manufacturer.
- **Controls:** A three-way tempering valve is required to control the radiant floor loop temperature.
- **Startup:** Adjust the three-way tempering valve to obtain the desired radiant loop set point. Then, with the radiant floor loop at or near full load, adjust the boiler side bypass/balancing valve to obtain the proper water temperature return to the boiler (e.g. 150°F).

Boiler - To - Radiant Floor

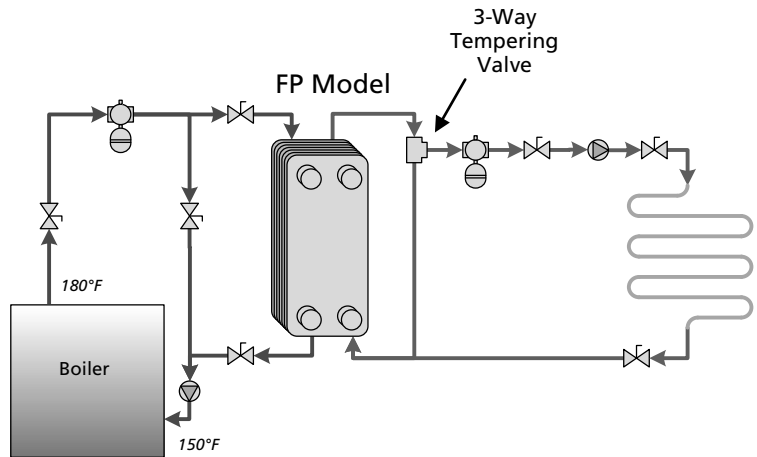

Hot Water Heater - To - Radiant Floor

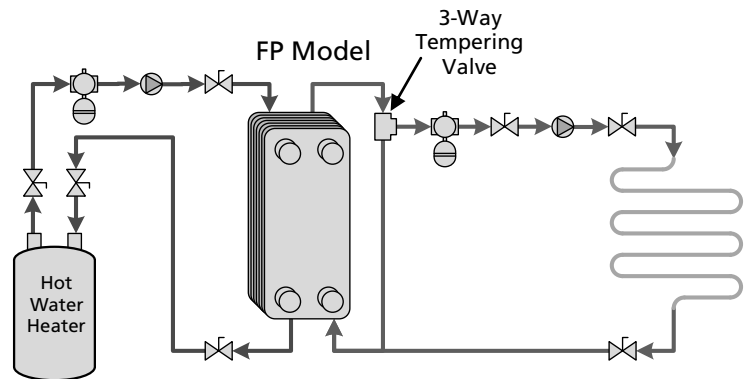

To find a wholesaler near you  
**Call 800-774-0474**  
Ask for Brazed Technical Support

To run your own detailed selection  
[www.flatplateselect.com](http://www.flatplateselect.com)



To find out more about FlatPlate®  
[www.flatplate.com](http://www.flatplate.com)

# Snow Melt Systems (FG, FP models)

## Application

Efficient heat transfer, with high output, fast response and separation of the glycol loop (the snow melt loop) from the boiler loop.

Typical snow melt systems are Boiler Water to Glycol Blend (10%-40%), depending on location and weather conditions, with the heat exchanger providing isolation of the glycol blend from the boiler water, providing an oxygen barrier to the boiler and protecting other components in the boiler system.

## FlatPlate Advantages

- Quicker response on a heating call.
- Smaller size than older technologies, for easier retrofit.
- Design Pressure is 300 psig, to handle most system requirements.
- Mounting Studs are included as standard to make mounting as easy as possible.
- ASME Code Stamp is available on request.

## Selection:

### Step One

- Determine the total BTUH required (using guidance from your radiant tube supplier) for the snow melt system.

### Step Two

- Select the appropriate FlatPlate heat exchanger, based on your BTUH needs.
- If the boiler water temperature is 180°F or higher, or steam, use the table as shown.
- If the boiler water temperature is less than 180°F, contact the factory for selection assistance.

### Step Three

- Check your selection to make sure that the minimum required flow rate and pressure drop are acceptable.
- If the system design requires a higher flow rate than the selection shown for either side, select a larger model to match the flow rate and pressure drop needs, or install a bypass balancing valve.
- This will allow full flow and optimum pressure drop for the pump.
- For example: For a system requiring 500,000 BTUH, you would normally select a FG10X20-20 (1/2" MPT). If the flow rate need is greater than 8.3, use the next larger model to match the pump equipment.

Snow Melt: 100°F Return, 120°F Supply (40% Propylene Glycol) Boiler: 180°F Supply, 150°F Return					
Capacity (BTUH)	Model and Size FP = Model 5X12L = Nominal Size -6 = Plate Count (3/4" MPT) = Connection	Side A (Boiler)		Side B (Snow Melt)	
		Minimum Required Flow Rate (GPM)	Pressure Drop (PSI) at the Min. Flow Rate	Minimum Required Flow Rate (GPM)	Pressure Drop (PSI) at the Min. Flow Rate
50,000	FP5X12L-6 (3/4" MPT)	3.4	1.4	5.4	2.0
100,000	FP5X12L-8 (3/4" MPT)	6.8	2.5	10.8	4.3
150,000	FP5X12L-12 (1" MPT)	10.2	2.1	16.2	4.4
200,000	FP5X12L-14 (1" MPT)	13.6	2.6	21.6	5.8
250,000	FP5X12L-16 (1" MPT)	17.0	3.0	27.0	7.0
300,000	FG10X20-20 (1-1/2" MPT)	20.5	2.7	32.4	6.7
350,000	FG10X20-20 (1-1/2" MPT)	23.9	1.2	37.8	3.0
400,000	FG10X20-20 (1-1/2" MPT)	27.3	1.6	43.2	3.9
450,000	FG10X20-20 (1-1/2" MPT)	30.7	2.0	48.6	4.8
500,000	FG10X20-20 (1-1/2" MPT)	34.1	2.4	54.1	5.9
600,000	FG10X20-24 (1-1/2" MPT)	40.9	2.3	64.9	6.0
700,000	FG10X20-30 (2" MPT)	47.7	2.0	75.7	5.4
800,000	FG10X20-30 (2" MPT)	54.5	2.6	86.5	7.0
900,000	FG10X20-40 (2" MPT)	61.4	2.0	97.3	5.3
1,000,000	FG10X20-40 (2" MPT)	68.2	2.4	108.1	6.5
1,100,000	FG10X20-50 (2-1/2" MPT)	75.0	2.0	118.9	5.5
1,200,000	FG10X20-50 (2-1/2" MPT)	81.8	2.3	129.7	6.4
1,300,000	FG10X20-60 (2-1/2" MPT)	88.6	2.1	140.5	5.7
1,400,000	FG10X20-60 (2-1/2" MPT)	95.5	2.4	151.4	6.6
1,500,000	FG10X20-70 (2-1/2" MPT)	102.3	2.2	162.2	6.1
1,600,000	FG10X20-70 (2-1/2" MPT)	109.1	2.5	173.0	6.9
1,700,000	FG10X20-80 (2-1/2" MPT)	115.9	2.3	183.8	6.5
1,800,000	FG10X20-90 (2-1/2" MPT)	122.7	2.3	194.6	6.4
1,900,000	FG10X20-100 (2-1/2" MPT)	129.6	2.3	205.4	6.3
2,000,000	FG10X20-100 (2-1/2" MPT)	136.4	2.5	216.2	7.0
2,100,000	FG10X20-110 (2-1/2" MPT)	143.2	2.5	227.0	7.0
2,200,000	FG10X20-130 (2-1/2" MPT)	150.0	2.4	237.8	6.6
2,300,000	FG10X20-140 (2-1/2" MPT)	156.8	2.5	248.7	6.9
2,400,000	FG10X20-160 (2-1/2" MPT)	163.6	2.5	259.5	6.8
2,500,000	FG10X20-180 (2-1/2" MPT)	170.5	2.6	270.3	6.9



Every FlatPlate heat exchanger is equipped with mounting studs, for easier, faster installation with our mounting bracket. Find the right size bracket on page 26.

To find a wholesaler near you  
**Call 800-774-0474**  
Ask for Brazed Technical Support

To run your own detailed selection  
[www.flatplateselect.com](http://www.flatplateselect.com)



To find out more about FlatPlate®  
[www.flatplate.com](http://www.flatplate.com)

# Snow Melt Systems (FG models)

## Installation, Control and Startup Notes:

### Piping:

- A boiler side bypass balancing valve is recommended, but not required.
- A Three-Way tempering valve or motorized control valve on the snow melt side is required.

### Controls:

- A Three-Way Tempering Valve is required to allow for adjustment of the snow melt side, and to limit the temperature of the glycol.
- For radiant tubing in sand, maximum glycol temperature is 140°F. In asphalt and concrete, maximum temperature is typically 150°F.
- Recommended set point is 130°F for the glycol snow melt side.

### Startup:

- Adjust the 3-way tempering valve to 130°F, OR to the desired set point.

### Installation:

- Do not use automotive anti-freeze because it will coat the heat exchanger plates and significantly reduce performance.

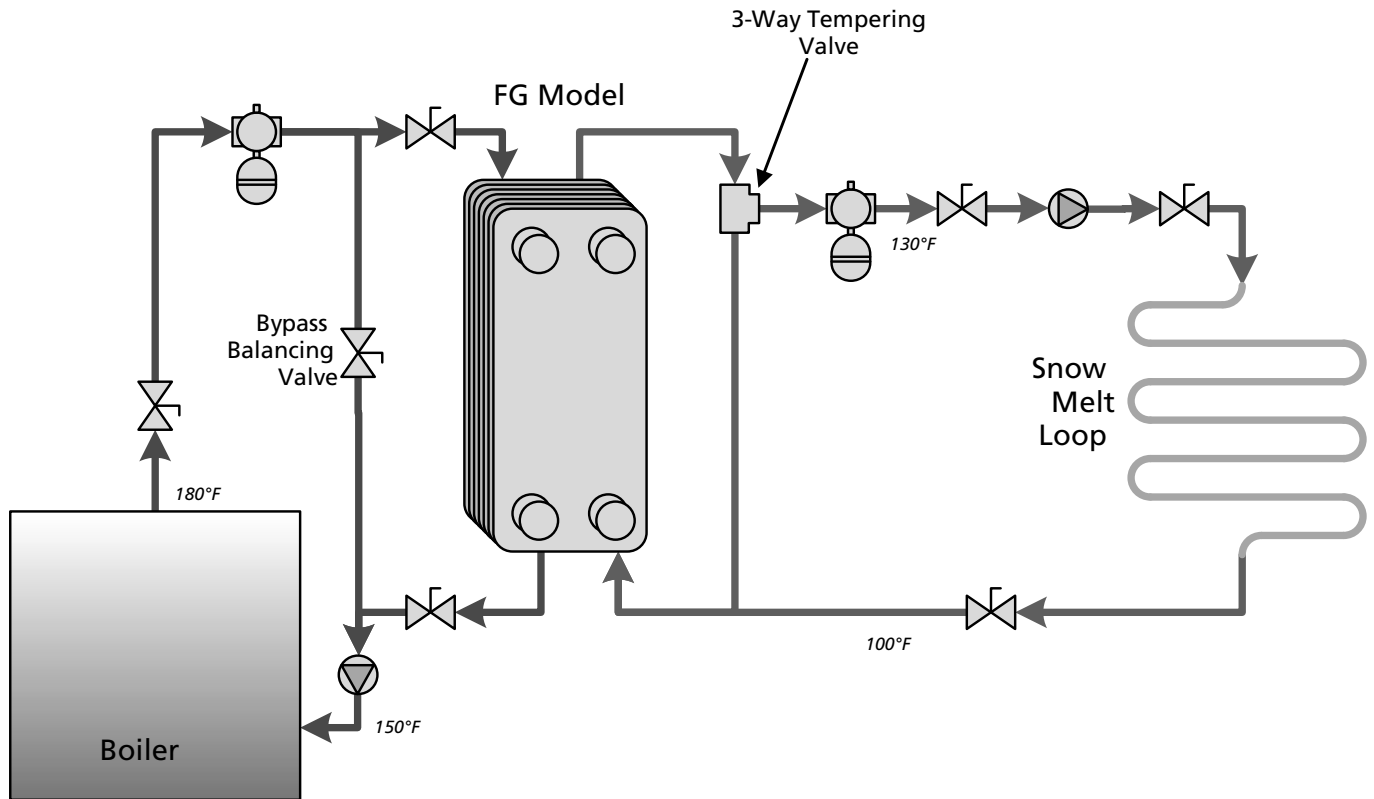

To find a wholesaler near you  
**Call 800-774-0474**  
Ask for Brazed Technical Support

To run your own detailed selection  
[www.flatplateselect.com](http://www.flatplateselect.com)



To find out more about FlatPlate®  
[www.flatplate.com](http://www.flatplate.com)

# Liquid-Liquid General Purpose (FG and FP models)

## Application

FlatPlate heat exchangers can be used in a wide range of applications, where the Approach Temperature is 10°F or less, and can deliver Approach Temperatures down to 2°F. This means that the Heating (or Cooling) source will heat (or cool) the Secondary load side to within 2-10°F of the Source temperature.

The result is that a FlatPlate heat exchanger can improve the performance of a wide range of systems, including:

- Boiler Water to Process Liquid
- Chilled Water to Process Liquid
- Glycol Blends to Process Water
- Process Water to Process Water
- Hot Water Heater to Radiant Floor
- Cooling Tower (Free Cooling) to Chilled Water Loop
- Engine Water to Process Liquid
- High Pressure (300 psig) Isolation to Low Pressure (150 psig) Equipment

## What is "Approach Temperature"?

It is the difference between the Hot Side In and the Cold Side Out temperatures..

*For example:*

*Side A (Hot): 95°F in, 85°F out*

*Side B (Cold): 77°F in, 87°F out*

*95 minus 87 gives you an 8°F approach temperature.*

The optimum approach temperature for a Braze Plate Heat Exchanger is typically 10°F for cost-effective selections, but 3°F and 4°F are possible for special applications.

## What is "Temperature Difference (TD)"?

There are always two Temperature Differences (TD) in a heat exchanger, one for each side. It is the difference between the In and Out temperatures on that side.

*For example:*

*Side A (Hot): 95°F in, 85°F out = 10°F TD*

*Side B (Cold): 77°F in, 87°F out = 10°F TD*

They are not always the same as each other. Ideal Temperature Difference is typically 10°F and is widely preferred in many applications.

Typical Piping Arrangement for 10°F and Higher Approach Temperatures

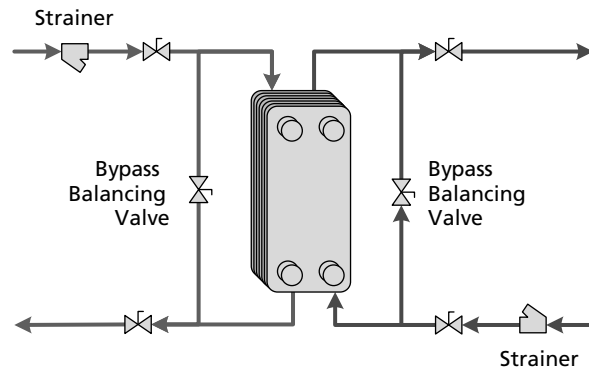

Typical Piping Arrangement Involving a Cooling Tower

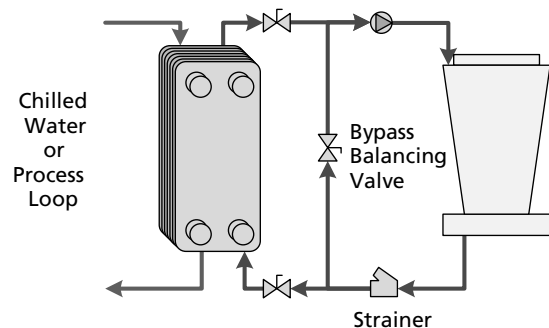

To find a wholesaler near you  
**Call 800-774-0474**  
Ask for Braze Technical Support

To run your own detailed selection  
[www.flatplateselect.com](http://www.flatplateselect.com)



To find out more about FlatPlate®  
[www.flatplate.com](http://www.flatplate.com)

# Liquid-Liquid General Purpose (FG and FP models)

## Selection:

### Step One

- Determine the total BTUH that you require.

### Step Two

- Find the appropriate model and size for the selected BTUH.

### Step Three

- If either entering fluid temperatures is below 80°F, use the Temperature Correction Table below. Multiply the Correction Factor times the plate count to obtain the appropriate model.

Temperature Correction Table	
Fluid Entering Temperature	Correction Factor
> 80°F	1.00
60°F - 80°F	1.21
32°F - 60°F	1.42

For example:

For a selection of an FP5X12-50 (meaning 50 plates), and an entering temperature on one side of 55°F, multiply the plate count of 50 times a correction of 1.21 to get an FP5X12-60 (meaning 60 plates) as the appropriate selection.

Side A Entering: 180°F, Leaving: 160°F Side B Entering: 140°F, Leaving: 160°F					
Capacity (BTUH)	Model and Size FG = Model 5X12 = Nominal Size -8 = Plate Count (3/4" MPT) = Connection	Side A (Liquid)		Side B (Liquid)	
		Minimum Required Flow Rate GPM	Pressure Drop (PSI) at the Min. Flow Rate	Minimum Required Flow Rate GPM	Pressure Drop (PSI) at the Min. Flow Rate
50,000	FG5X12-8 (3/4" MPT)	5.1	6.6	5.1	3.9
100,000	FG5X12-14 (3/4" MPT)	10.2	6.6	10.2	5.0
150,000	FG5X12-20 (1" MPT)	15.4	6.7	15.4	5.6
200,000	FG5X12-24 (1" MPT)	20.5	8.0	20.5	6.9
300,000	FG5X12-36 (1-1/4" MPT)	30.7	7.9	30.7	7.2
400,000	FG5X12-50 (1-1/4" MPT)	41.0	7.6	41.0	7.2
500,000	FG5X12-70 (1-1/4" MPT)	51.2	6.8	51.2	6.6
600,000	FG5X12-80 (1-1/4" MPT)	61.4	8.0	61.4	7.8
700,000	FP10X20L-24 (1-1/2" MPT)	71.7	6.7	71.7	5.8
800,000	FP10X20L-30 (2" MPT)	81.9	5.7	81.9	5.1
900,000	FP10X20L-30 (2" MPT)	92.9	7.1	92.9	6.4
1,000,000	FP10X20L-40 (2" MPT)	102.4	5.2	102.4	4.8
1,250,000	FP10X20L-40 (2" MPT)	128.0	7.9	128.0	7.3
1,500,000	FP10X20L-50 (2-1/2" MPT)	153.6	7.7	153.6	7.4
1,750,000	FP10X20L-60 (2-1/2" MPT)	179.2	7.9	179.2	7.6
2,000,000	FP10X20L-80 (2-1/2" MPT)	204.8	7.0	204.8	6.9
2,250,000	FP10X20L-90 (2-1/2" MPT)	230.4	7.7	230.4	7.6
2,500,000	FP15X34AL-80-FB (4" FLG)	256.0	7.7	256.0	2.9
2,750,000	FP15X34AL-90-FB (4" FLG)	281.6	7.4	281.6	2.8
3,000,000	FP15X34AL-100-FB (4" FLG)	307.2	7.2	307.2	2.8



Every FlatPlate heat exchanger is equipped with mounting studs, for easier, faster installation with our mounting bracket. Find the right size bracket on page 26.

To find a wholesaler near you  
**Call 800-774-0474**  
 Ask for Brazed Technical Support

To run your own detailed selection  
[www.flatplateselect.com](http://www.flatplateselect.com)



To find out more about FlatPlate®  
[www.flatplate.com](http://www.flatplate.com)

# Steam-Liquid General Purpose (MPN models)

## Application

Steam is commonly used as a heating medium in a wide range of applications. If your application is not present in other parts of this catalog, but you know you are using steam as a heat source, use this sizing method.

## FlatPlate® Advantages

- Quicker response on a heating call.
- Smaller size than older technologies, easier for retrofit.
- Design Pressure is 300 psig, to handle most system requirements.
- Mounting Studs are included as standard to make mounting as easy as possible.
- ASME Code Stamp is available on request.

## Selection:

### Step One

- Determine the total BTUH you need.

### Step Two

- Select the appropriate heat exchanger size from the table at the right, based on your BTUH needs.

### Step Three

- Check your selection to make sure that the minimum required flow rate and pressure drop are acceptable.
- If the system design requires a higher flow rate than the selection shown for either side, select a larger model to match the flow rate and pressure drop needs, or install a bypass balancing valve.
- This will allow full flow and optimum pressure drop for the pump.
- For example: For a system requiring 1,000,000 BTUH, you would normally select a MPN10X20L-30 (1-1/2" MPT). If the flow rate requirement is greater than 25.2 GPM, use the next larger model to match the pump equipment.

Steam Superheat = 50°F, Steam Pressure: 4 PSIG, Maximum Steam Pressure Drop: 1.5 PSI Water In Temperature: 60°F, Water Out Temperature: 140°F				
Capacity (BTUH)	Model and Size MPN = Model 5X12 = Nominal Size -8 = Plate Count (1" MPT) = Connection	Side A (Steam)	Side B (Liquid)	
		Pressure Drop (PSI)	Minimum Required Flow Rate GPM	Pressure Drop (PSI) at the Min. Flow Rate
50,000	MPN5X12-8 (1" MPT)	1.3	1.3	0.3
100,000	MPN5X12-14 (1" MPT)	1.3	2.5	0.4
150,000	MPN5X12-20 (1-1/4" MPT)	1.3	3.8	0.4
200,000	MPN5X12-24 (1-1/4" MPT)	1.5	5.0	0.5
300,000	MPN5X12-36 (1-1/4" MPT)	1.4	7.5	0.5
400,000	MPN5X12-50 (1-1/4" MPT)	1.3	10.1	0.5
500,000	MPN5X12-60 (1-1/4" MPT)	1.4	12.6	0.6
600,000	MPN5X12-70 (1-1/4" MPT)	1.4	15.1	0.7
700,000	MPN5X12-80 (1-1/4" MPT)	1.5	17.6	0.8
800,000	MPN5X12-90 (1-1/4" MPT)	1.5	20.1	0.8
900,000	MPN5X12-100 (1-1/4" MPT)	1.5	22.6	0.9
1,000,000	MPN10X20L-30 (1-1/2" MPT)	1.5	25.2	0.6
1,250,000	MPN10X20L-40 (1-1/2" MPT)	1.3	31.5	0.5
1,500,000	MPN10X20L-50 (1-1/2" MPT)	1.2	37.7	0.5
1,750,000	MPN10X20L-60 (1-1/2" MPT)	1.1	44.0	0.5
2,000,000	MPN10X20L-60 (1-1/2" MPT)	1.5	50.3	0.7
2,250,000	MPN10X20L-70 (1-1/2" MPT)	1.4	56.6	0.7
2,500,000	MPN10X20L-80 (1-1/2" MPT)	1.3	62.9	0.7
2,750,000	MPN10X20L-80 (1-1/2" MPT)	1.5	69.2	0.9
3,000,000	MPN10X20L-90 (1-1/2" MPT)	1.4	75.5	0.9



Every FlatPlate heat exchanger is equipped with mounting studs, for easier, faster installation with our mounting bracket. **Find the right size bracket on page 26.**

To find a wholesaler near you  
**Call 800-774-0474**  
Ask for Braze Technical Support

To run your own detailed selection  
**www.flatplateselect.com**



To find out more about FlatPlate®  
**www.flatplate.com**

# Steam-Liquid General Purpose (MPN models)

## Selection Notes:

- When selecting the heat exchanger, remember that steam pressure at the heat exchanger inlet is equal to supply pressure less open-valve pressure drop.
- When calculating pressure drop through the steam side loop, remember to include pressure drop through the Float & Thermostatic Trap (F&T).

## Piping Notes:

- Install the steam side Control Valve upstream from the heat exchanger.
- For the Control Valve, always use a modulating design, never a 2-position or solenoid valve.
- Install the Vacuum Breaker downstream of the Control Valve, but upstream of the Heat Exchanger.
- Install the Vacuum Breaker physically above the heat exchanger.
- Install the Float and Thermostatic Trap (F&T) physically below the heat exchanger.
- Install the heat exchanger in a space where the ambient temperature is always above 33°F (0.5°C).

## Control Notes:

- Always keep the Liquid Side temperatures below the boiling point of the media.
- Never let the Liquid Side temperature go below 33°F (0.5°C).
- Set the controls so that the Liquid Side media is flowing before the Control Valve opens.
- To avoid damage from thermal shock, ensure that the initial Control Valve opening rate is limited.

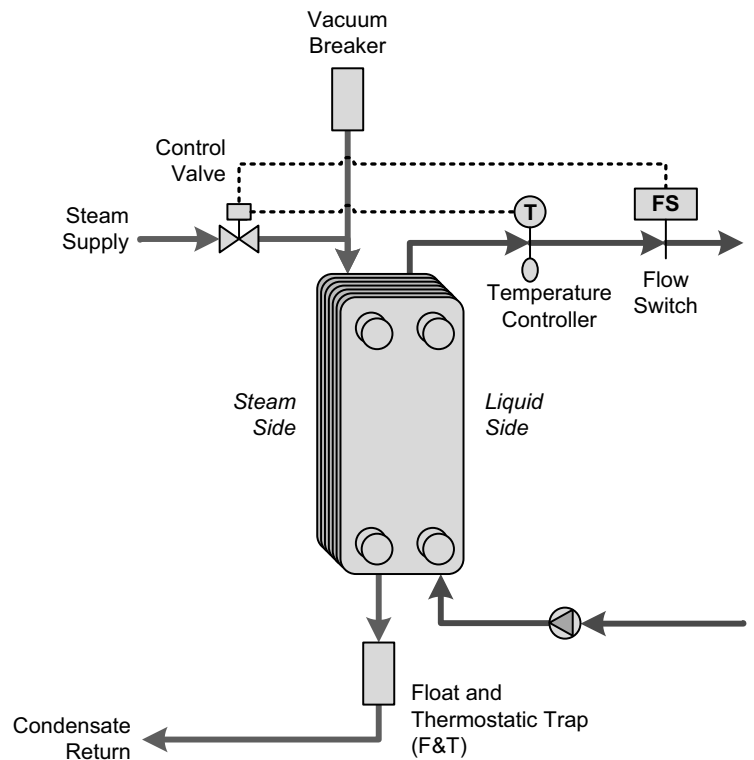

To find a wholesaler near you  
**Call 800-774-0474**  
Ask for Brazed Technical Support

To run your own detailed selection  
[www.flatplateselect.com](http://www.flatplateselect.com)



To find out more about FlatPlate®  
[www.flatplate.com](http://www.flatplate.com)

# Swimming Pools & Spas (MPN, VT04 and NT50 models)

## Application:

### The Challenge of Harsh Chemicals.

Swimming pools and spas can be very hard on heat exchangers because of the elevated chloride levels. Ordinary materials, including 304 and 316 stainless steel, just don't hold up well even at normal levels, and chloride levels can go even higher during shocking.

Additionally, pool mechanical systems are frequently located in small areas, with space at a premium, and ordinary heat exchangers take up a large part of that space.

### The Answer

GEA PHE Systems plate heat exchangers, designed specifically for use in elevated chloride applications. The MPN Series (brazed), VT04 (gasketed) and NT50T (gasketed) plate heat exchangers share these benefits:

- **Compact and Efficient.** As little as 1/5 the size of comparably-performing other technologies, taking much less space, and making it easier to replace a failed heat exchanger that failed.
- **Durable.** Highly corrosion resistant materials and construction provide the added resistance you need to compensate for the higher chloride content.
- **Flexible.** Available in a range of sizes to fit your needs. For pools ranging from 1,000 to 200,000 gallons, and spa sizes from 750 to 8,000 gallons

### MPN Series brazed plate heat exchangers

- Nickel-Chrome Brazing provides durability unmatched by traditional plate heat exchangers, while still delivering the flexible performance and compact size that are the hallmarks of brazed plate heat exchangers.
- No ordinary stainless steel will do. We use an extra-corrosion-resistant marine grade of stainless steel, with 37 times the resistance of type 304 stainless steel.

### Model VT04 and NT50T gasketed plate heat exchangers

- Maximum corrosion resistance. Titanium plates and connections combine with NBR (Nitrile Butyl Rubber) gaskets to ensure the best corrosion resistance available.
- Titanium Grade One plate material has **2500** times the chloride corrosion resistance of type 304 stainless steel.
- Completely serviceable, with individually cleanable plates, gaskets and connections.
- **Recommended for use with electronic chlorinating devices.**

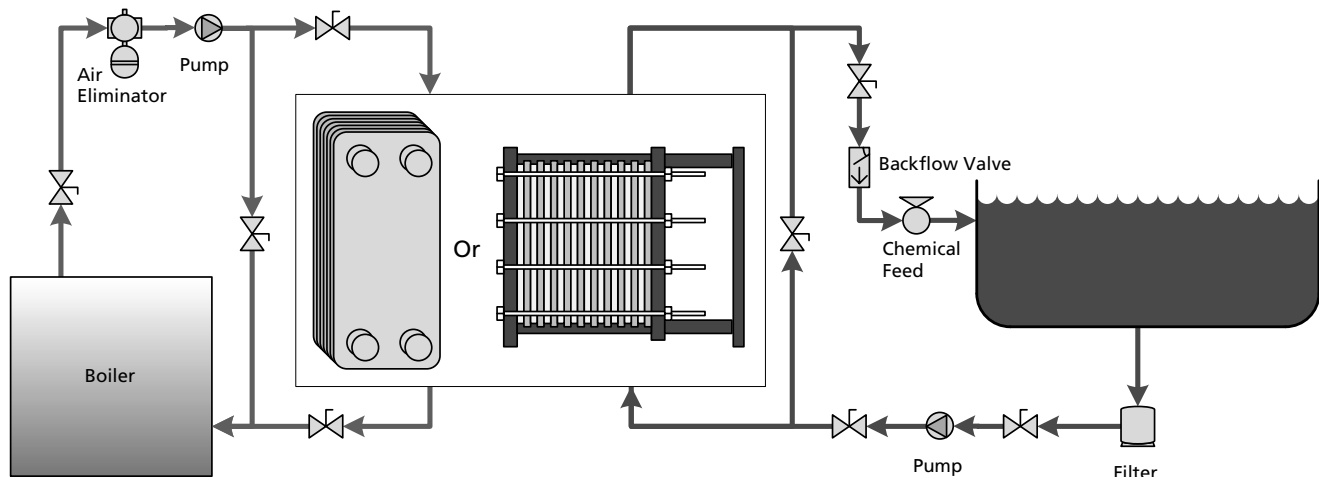

To find a wholesaler near you  
**Call 800-774-0474**  
Ask for Brazed Technical Support

To run your own detailed selection  
[www.flatplateselect.com](http://www.flatplateselect.com)



To find out more about FlatPlate®  
[www.flatplate.com](http://www.flatplate.com)



# Swimming Pools & Spas (MPN, VT04 and NT50 models)

## MPN Selection for Swimming Pools

1. Select the heat-up rate you want.

Pool Use	Heat-Up Rate
Periodic use only (weekends and holidays)	2°F per hour
Extended use (summer season)	1°F per hour.

2. Determine your pool volume (in cubic feet).

- Rectangular Pools: Length x Width x Average Depth x 7.5 (gallons per cubic foot)
- Circular Pools: Diameter x Diameter x Average Depth x 0.785 x 7.5 (gallons per cubic foot)

3. Select the Heat Exchanger and the Boiler Output Required.

- From the tables below, find the appropriate size of MPN for your pool.

4. Verify that the boiler output exceeds the heat loss to surroundings.

- Heat Loss (BTUH) = (12 x Pool Surface Area x Desired Pool Temp) - Coldest Ambient Temp during use.

5. Make corrections if needed.

- For **160°F boiler water**, increase the plate count by 50% (e.g. for a 5x12 16-plate unit, change to a 5x12 with 24 plates).
- For **200°F boiler water and steam**, use the same model size, and multiply the required minimum boiler side flow rate by 0.6.



Every FlatPlate heat exchanger is equipped with mounting studs, for easier, faster installation with our mounting bracket. Find the right size bracket on page 26.

Pool Volume (gallons)	1°F Per Hour Heat-Up Rate				2°F Per Hour Heat-Up Rate			
	Model and Size MPN = Model 5X12 = Nominal Size -4 = Plate Count (3/4" MPT) = Connection	Minimum Required Flow Rate (GPM)	Pressure Drop (PSI) at the Min. Flow Rate	Req. Boiler Output (BTUH)	Model and Size 5X12 = Nominal Size -4 = Plate Count (3/4" MPT) = Connection	Minimum Required Flow Rate (GPM)	Pressure Drop (PSI) at the Min. Flow Rate	Req. Boiler Output (BTUH)
1,000	MPN5X12-4 (1" MPT)	2	8.7	8,345	MPN5X12-4 (1" MPT)	2	8.7	16,690
2,000	MPN5X12-4 (1" MPT)	2	8.7	16,690	MPN5X12-6 (1" MPT)	2	2.4	33,380
4,000	MPN5X12-6 (1" MPT)	2	2.4	33,380	MPN5X12-8 (1" MPT)	4	4.1	66,760
6,000	MPN5X12-6 (1" MPT)	3	5.1	50,070	MPN5X12-10 (1" MPT)	7	6.9	100,140
8,000	MPN5X12-8 (1" MPT)	4	4.1	66,760	MPN5X12-10 (1" MPT)	9	11.0	133,520
10,000	MPN5X12-8 (1" MPT)	6	5.1	83,450	MPN5X12-16 (1" MPT)	11	5.7	166,900
12,000	MPN5X12-10 (1" MPT)	7	6.9	100,140	MPN5X12-16 (1" MPT)	13	7.8	200,280
15,000	MPN5X12-10 (1" MPT)	8	8.0	125,175	MPN5X12-20 (1-1/4" MPT)	17	8.1	250,350
20,000	MPN5X12-16 (1" MPT)	11	5.7	166,900	MPN5X12-24 (1-1/4" MPT)	22	9.2	333,800
25,000	MPN5X12-16 (1" MPT)	14	9.0	208,625	MPN5X12-30 (1-1/4" MPT)	28	9.3	417,250
30,000	MPN5X12-20 (1-1/4" MPT)	17	8.1	250,350	MPN5X12-40 (1-1/4" MPT)	33	7.4	500,700
35,000	MPN5X12-20 (1-1/4" MPT)	18	9.1	292,075	MPN5X12-40 (1-1/4" MPT)	36	8.7	584,150
40,000	MPN5X12-24 (1-1/4" MPT)	19	6.9	333,800	MPN5X12-50 (1-1/4" MPT)	38	6.6	667,600
45,000	MPN5X12-30 (1-1/4" MPT)	21	5.4	375,525	MPN5X12-50 (1-1/4" MPT)	43	8.4	751,050
50,000	MPN5X12-30 (1-1/4" MPT)	24	7.0	417,250	MPN5X12-60 (1-1/4" MPT)	48	7.6	834,500
60,000	MPN5X12-40 (1-1/4" MPT)	29	5.8	500,700	MPN5X12-70 (1-1/4" MPT)	57	8.4	1,001,400
70,000	MPN5X12-40 (1-1/4" MPT)	33	7.5	584,150	MPN10X20L-20 (1-1/2" MPT)	60	13.6	1,168,300
80,000	MPN5X12-50 (1-1/4" MPT)	38	6.6	667,600	MPN10X20L-24 (1-1/2" MPT)	69	12.1	1,335,200
90,000	MPN5X12-50 (1-1/4" MPT)	43	8.3	751,050	MPN10X20L-30 (2" MPT)	77	9.8	1,502,100
100,000	MPN5X12-60 (1-1/4" MPT)	48	7.6	834,500	MPN10X20L-30 (2" MPT)	86	11.7	1,669,000
125,000	MPN5X12-70 (1-1/4" MPT)	60	9.2	1,043,025	MPN10X20L-36 (2" MPT)	107	12.5	2,086,250
150,000	MPN10X20L-24 (1-1/2" MPT)	54	10.8	1,251,750	MPN10X20L-50 (2-1/2" MPT)	129	9.6	2,503,500
175,000	MPN10X20L-30 (2" MPT)	75	9.3	1,460,375	MPN10X20L-60 (2-1/2" MPT)	150	9.3	2,920,750

To find a wholesaler near you  
**Call 800-774-0474**  
 Ask for Brazed Technical Support

To run your own detailed selection  
[www.flatplateselect.com](http://www.flatplateselect.com)



To find out more about FlatPlate®  
[www.flatplate.com](http://www.flatplate.com)

# Swimming Pools & Spas (MPN, VT04 and NT50T models)

## VT04 and NT50T Selection for Swimming Pools

1. Select the heat-up rate you want.

Pool Use	Heat-Up Rate
Periodic use only (weekends and holidays)	2°F per hour.
Extended use (summer season)	1°F per hour.

2. Determine your pool volume (in cubic feet).

- Rectangular Pools: Length x Width x Average Depth x 7.5 (gallons per cubic foot)
- Circular Pools: Diameter x Diameter x Average Depth x 0.785 x 7.5 (gallons per cubic foot)

3. Select the Heat Exchanger and the Boiler Output Required.

- From the tables below, find the appropriate size of VT04 or NT50T for your pool.

4. Verify that the boiler output exceeds the heat loss to surroundings.

- Heat Loss (BTUH) = (12 x Pool Surface Area x Desired Pool Temp) - Coldest Ambient Temp during use.

5. Make corrections if needed.

- For **160°F boiler water**, increase the plate count by 50% (e.g. for a VT04-5, change to a VT04-7).
- For **200°F boiler water and steam**, use the same model size, and multiply the required min. boiler side flow rate by 0.6.

Pool Volume (gallons)	1°F Per Hour Heat-Up Rate				2°F Per Hour Heat-Up Rate			
	Model and Size VT04 = Model -5 = Plate Count (1-1/4" MPT) = Connection	Minimum Required Flow Rate (GPM)	Pressure Drop (PSI) at the Min. Flow Rate	Req. Boiler Output (BTUH)	Model and Size VT04 = Model -5 = Plate Count (1-1/4" MPT) = Connection	Minimum Required Flow Rate (GPM)	Pressure Drop (PSI) at the Min. Flow Rate	Req. Boiler Output (BTUH)
1,000	VT04-5 (1-1/4" MPT)	0.4	0.22	8,310	VT04-5 (1-1/4" MPT)	0.7	0.60	16,620
2,000	VT04-5 (1-1/4" MPT)	0.7	0.60	16,620	VT04-5 (1-1/4" MPT)	1.7	3.06	33,240
4,000	VT04-5 (1-1/4" MPT)	1.7	3.06	33,240	VT04-5 (1-1/4" MPT)	2.6	1.88	66,480
6,000	VT04-5 (1-1/4" MPT)	1.8	0.96	49,860	VT04-5 (1-1/4" MPT)	4.4	4.94	99,720
8,000	VT04-5 (1-1/4" MPT)	2.6	1.88	66,480	VT04-7 (1-1/4" MPT)	5.3	3.33	132,960
10,000	VT04-5 (1-1/4" MPT)	3.4	3.07	83,100	VT04-7 (1-1/4" MPT)	7.0	5.56	166,200
12,000	VT04-5 (1-1/4" MPT)	4.4	4.94	99,710	VT04-9 (1-1/4" MPT)	7.9	4.14	199,420
15,000	VT04-5 (1-1/4" MPT)	4.8	2.78	124,640	VT04-9 (1-1/4" MPT)	10.6	7.12	249,280
20,000	VT04-7 (1-1/4" MPT)	7.0	5.56	166,190	VT04-11 (1-1/4" MPT)	14.0	8.00	332,380
25,000	VT04-9 (1-1/4" MPT)	8.4	4.63	207,740	VT04-15 (1-1/4" MPT)	17.0	6.38	415,480
30,000	VT04-9 (1-1/4" MPT)	10.6	7.12	249,290	VT04-15 (1-1/4" MPT)	21.0	9.42	498,580
35,000	VT04-11 (1-1/4" MPT)	12.0	6.02	290,830	VT04-21 (1-1/4" MPT)	23.0	6.16	581,660
40,000	VT04-11 (1-1/4" MPT)	14.0	8.00	332,380	VT04-21 (1-1/4" MPT)	27.0	8.28	664,760
45,000	VT04-15 (1-1/4" MPT)	15.0	5.06	373,930	VT04-29 (1-1/4" MPT)	28.0	5.28	747,860
50,000	VT04-15 (1-1/4" MPT)	17.0	6.38	415,480	VT04-29 (1-1/4" MPT)	33.0	7.14	830,960
60,000	VT04-15 (1-1/4" MPT)	21.0	9.42	498,570	VT04-37 (1-1/4" MPT)	38.0	6.53	997,140
70,000	VT04-21 (1-1/4" MPT)	23.0	6.16	581,670	VT04-45 (1-1/4" MPT)	44.0	6.65	1,163,340
80,000	VT04-21 (1-1/4" MPT)	27.0	8.28	664,760	VT04-55 (1-1/4" MPT)	49.0	6.47	1,329,520
90,000	VT04-29 (1-1/4" MPT)	28.0	5.28	747,860	VT04-55 (1-1/4" MPT)	57.0	8.53	1,495,720
100,000	VT04-29 (1-1/4" MPT)	33.0	7.14	830,950	VT04-67 (1-1/4" MPT)	61.0	7.98	1,661,900
125,000	VT04-37 (1-1/4" MPT)	41.0	7.17	1,038,690	NT50T-21 (2" MPT)	82.0	6.38	2,077,380
150,000	VT04-45 (1-1/4" MPT)	47.0	7.80	1,246,430	NT50T-25 (2" MPT)	98.0	6.62	2,492,860
175,000	VT04-55 (1-1/4" MPT)	55.0	7.99	1,454,160	NT50T-29 (2" MPT)	114.0	6.90	2,908,320
200,000	VT04-67 (1-1/4" MPT)	61.0	7.98	1,661,900	NT50T-33 (2" MPT)	130.0	7.22	3,323,800

To find a wholesaler near you  
**Call 800-774-0474**  
 Ask for Brazed Technical Support

To run your own detailed selection  
[www.flatplateselect.com](http://www.flatplateselect.com)



To find out more about FlatPlate®  
[www.flatplate.com](http://www.flatplate.com)

# Swimming Pools & Spas (MPN, VT04 and NT50T models)

## MPN Selection for Spas and Hot Tubs

1. Determine your spa or hot tub volume (in cubic feet).

- Rectangular: Length x Width x Average Depth x 7.5 (gallons per cubic foot)
- Circular: Diameter x Diameter x Average Depth x 0.785 x 7.5 (gallons per cubic foot)

2. Select the Heat Exchanger and the Boiler Output Required.

- From the table, find the appropriate size of MPN for your spa or hot tub.

3. Verify that the boiler output exceeds the heat loss to surroundings.

- Heat Loss (BTUH) = (12 x Spa Surface Area x Desired Spa Temp) - Coldest Ambient Temp during use.

4. Make corrections if needed.

- For **160°F boiler water**, increase the plate count by 50% (e.g. for a 5x10 10-plate unit, change to a 5x12 with 16 plates).
- For **200°F boiler water and steam**, use the same model size, and multiply the required min. boiler side flow rate by 0.6.

Volume (gallons)	Model and Size MPN = Model 5X12 = Nominal Size -6 = Plate Count (1" MPT) = Connection	1°F Per Hour Heat-Up Rate		
		Minimum Required Boiler Side Flow Rate (GPM)	Pressure Drop (PSI) at the Min. Flow Rate	Req. Boiler Output (BTUH)
750	MPN5X12-6 (1" MPT)	2	2.9	31,300
1,000	MPN5X12-8 (1" MPT)	3	2.9	41,725
1,500	MPN5X12-10 (1" MPT)	4	2.9	62,588
2,000	MPN5X12-16 (1" MPT)	6	2.2	83,450
4,000	MPN5X12-20 (1-1/4" MPT)	11	3	166,900
6,000	MPN5X12-30 (1-1/4" MPT)	17	4.3	250,350
8,000	MPN5X12-40 (1-1/4" MPT)	22	4.1	333,800

## VT04 Selection for Spas and Hot Tubs

1. Determine your spa or hot tub volume (in cubic feet).

- Rectangular: Length x Width x Average Depth x 7.5 (gallons per cubic foot)
- Circular: Diameter x Diameter x Average Depth x 0.785 x 7.5 (gallons per cubic foot)

2. Select the Heat Exchanger and the Boiler Output you need.

- From the table, find the appropriate size of VT04 for your spa or hot tub.

3. Verify that the boiler output exceeds the heat loss to surroundings.

- Heat Loss (BTUH) = (12 x Spa Surface Area x Desired Spa Temp) - Coldest Ambient Temp during use.

4. Make corrections if needed.

- For **160°F boiler water**, increase the plate count by 50% (e.g. for a 5-plate unit, change to unit with 7 plates).
- For **200°F boiler water and steam**, use the same model size, and multiply the required min. boiler side flow rate by 0.6.

Volume (gallons)	Model and Size VT04 = Model -5 = Plate Count (1-1/4" MPT) = Connection	2°F Per Hour Heat-Up Rate, Plus Aeration		
		Minimum Required Boiler Side Flow Rate (GPM)	Pressure Drop (PSI) at the Min. Flow Rate	Minimum Required Boiler Output (BTUH)
1,000	VT04-5 (1-1/4" MPT)	0.7	0.60	16,620
2,000	VT04-5 (1-1/4" MPT)	1.7	3.06	33,240
4,000	VT04-5 (1-1/4" MPT)	2.6	1.88	66,480
6,000	VT04-5 (1-1/4" MPT)	4.4	4.94	99,720
8,000	VT04-7 (1-1/4" MPT)	5.3	3.33	132,960

To find a wholesaler near you  
**Call 800-774-0474**  
 Ask for Brazed Technical Support

To run your own detailed selection  
[www.flatplateselect.com](http://www.flatplateselect.com)



To find out more about FlatPlate®  
[www.flatplate.com](http://www.flatplate.com)

# Swimming Pools & Spas (MPN, VT04 and NT50T models)

## Installation Notes

### Piping:

- Pools and Spas always have high water flow rates, from 30 to 50 gpm for a typical residential pool, to higher flow rates for commercial applications.
- Because FlatPlate heat exchangers have high efficiency, they do not require the full pool flow, and we recommend a bypass balancing valve to bypass 50% to 80% of the pool water.
- This bypass/balancing valve should be adjusted and permanently set at startup.
- Chemical feeds **MUST** be downstream from the heat exchanger, and a check valve should also be installed to prevent back-flow of chemicals into the heat exchanger when the pump is not in operation.

### Controls:

- Temperature control of the pool should be based on a return water temperature stat, controlling (on/off) the boiler and boiler pump.
- Temperature control of the 90-100°F feed to the pool should be controlled by permanent adjustment of the bypass valve.

### Startup:

- Start up the system, and adjust the pool side bypass valve so that the pool heats up no faster than 2°F/hour, initially.
- After the pool reaches approximately 78-80°F, and the boiler water is entering at 180°F, adjust the pool side bypass/balancing valve to obtain 90-100°F water to the pool.
- Then adjust the boiler bypass/balancing valve so that approximately 150°F water is being returned to the boiler.

### Maintenance Notes:

- When cleaning the pool water in the spring with the filter, cut the heat exchanger out of the loop with the cutout valves, to minimize the effect on the heat exchanger of any shocking that might be done.

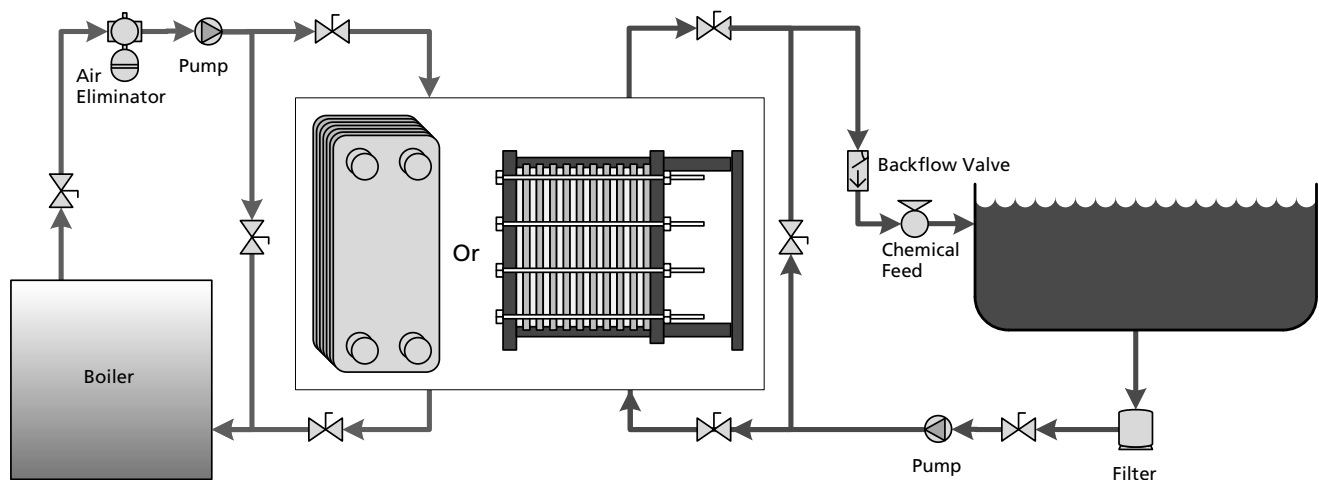

To find a wholesaler near you  
**Call 800-774-0474**  
Ask for Brazed Technical Support

To run your own detailed selection  
[www.flatplateselect.com](http://www.flatplateselect.com)



To find out more about FlatPlate®  
[www.flatplate.com](http://www.flatplate.com)

# Large Capacity / Low Pressure Drop

## Application

Look to this chart when you need a capacity that is larger than a single heat exchanger is capable of, but where you want the convenience of a single piping arrangement. Especially useful in replacing a shell-and-tube heat exchanger in an existing installation. The result is that a FlatPlate heat exchanger can improve the performance of the systems shown below, at a much higher duty than normally expected:

- Boiler Water to Process Liquid Chilled Water to Process Liquid Glycol Blends to Process Water Process Water to Process Water Hot Water Heater to Radiant Floor Cooling Tower (Free Cooling) to Chilled Water Loop
- Engine Water to Process Liquid High Pressure (300 psig) Isolation to Low Pressure (150 psig) Equipment

## The FlatPlate Advantage

- Available in side-by-side configuration (Horizontal Manifold) or in over-under configuration (Vertical Manifold) to make maximum use of the small-size benefit of FlatPlate heat exchangers.
- Quicker response on a heating call.
- Design Pressure is 300 psig, to handle most system requirements.
- ASME Code Stamp is available on request (on the heat exchangers only).

## Selection Range

The table at right shows selection for large capacity liquid-liquid applications. Many FlatPlate models can be manifolded to handle significantly larger duties. Contact your FlatPlate representative for selection assistance on these applications:

- Direct Expansion Liquid Evaporators
- Liquid Condensers
- Heat Pumps
- Sub-Coolers
- Air Dryers

Side A Entering: 180°F, Leaving: 160°F Side B Entering: 140°F, Leaving: 160°F					
Capacity (BTUH)	Model and Size FP = Model 10X20L = Nominal Size -8 = Plate Count M = Manifold, Horizontal (4" FLG) = Connection	Side A (Liquid)		Side B (Liquid)	
		Minimum Required Flow Rate GPM	Pressure Drop (PSI) at the Min. Flow Rate	Minimum Required Flow Rate GPM	Pressure Drop (PSI) at the Min. Flow Rate
3,000,000	FP10X20L-160M (4" FLG)	307.0	4.0	306.0	3.9
3,500,000	FP10X20L-160M (4" FLG)	358.0	5.4	357.0	5.3
4,000,000	FP10X20L-160M (4" FLG)	410.0	7.0	408.0	6.9
4,500,000	FP10X20L-200M (4" FLG)	461.0	6.9	459.0	6.9
5,000,000	FP10X20L-240M (4" FLG)	512.0	7.3	510.0	7.2
5,500,000	FP10X20L-280M (4" FLG)	563.0	7.9	561.0	7.8
6,000,000	FP10X20L-360M (4" FLG)	614.0	8.1	612.0	8.0
6,500,000	FP10X20L-400M (4" FLG)	666.0	9.1	662.0	9.1

Note: The model and size shown above are for the Horizontal Manifold assembly. To order the Vertical Manifold assembly, change the "M" to "MV".

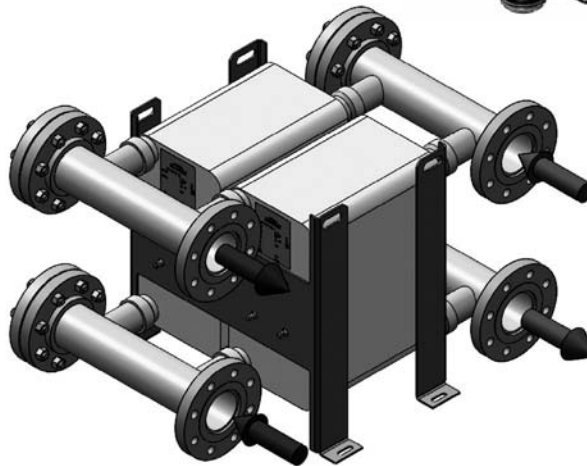
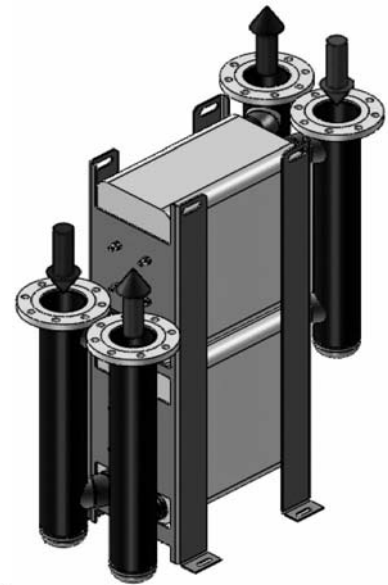

To find a wholesaler near you  
**Call 800-774-0474**  
Ask for Brazed Technical Support

To run your own detailed selection  
[www.flatplateselect.com](http://www.flatplateselect.com)



To find out more about FlatPlate®  
[www.flatplate.com](http://www.flatplate.com)

# Replacing a Shell-And-Tube Heat Exchanger

## Application:

FlatPlate heat exchangers are much smaller and lighter than shell-and-tube heat exchangers, making them ideal for replacing a shell-and-tube unit in the field.

Selecting the appropriate FlatPlate heat exchanger is easy.

Following are two different methods which will both give you exact performance match or improved performance.

## Method A. Heat Transfer Surface Method.

This matches the heat transfer surface area of the heat exchanger, which defines the nominal performance of the unit. Because FlatPlate units perform 20-80% better than shell-and-tube heat exchangers, on a heat transfer surface basis, a 20-80% safety factor is embedded in this method. This works for almost any type of fluid-to-fluid and steam-to-fluid heat exchanger.

### Step One

- Count the number of tubes in the shell-and-tube heat exchanger.

### Step Two.

- Measure the external diameter of the tubes to the nearest 1/8".
- If the tubes have fins or protrusions, stop here and call your FlatPlate representative.

### Step Three.

- Measure the length of the tube(s) from end sheet to end sheet to the nearest inch.
- If it is a U-tube bundle, then use the overall length of the U-tube bundle.

### Step Four.

- Multiply these numbers to get your Heat Transfer Surface Area in ft<sup>2</sup>:

Tube Quantity  
 x Tube Diameter (in inches)  
 x 3.14  
 x Tube Length (in inches)  
 x 0.0069  
 x 1.2

### Step Five.

- Select the closest corresponding FlatPlate heat exchanger from the chart at right.
- For CuNi-Cupronickel or brass shell and tube replacements, substitute the same sizes as the chart as right, but in the MPN model.
- For Steam or Swimming Pool applications, or other applications with questionable water quality, substitute an MPN model in the same size.

Heat Transfer Surface Area (Ft <sup>2</sup> )	Model and Size FG = Model 5X12 = Nominal Size -8 = Plate Count (3/4" MPT) = Connection
2.5	FG5X12-8 (3/4" MPT)
5	FG5X12-14 (3/4" MPT)
7.5	FG5X12-20 (1" MPT)
10	FG5X12-30 (1" MPT)
12.5	FG5X12-40 (1-1/4" MPT)
15	FG5X12-50 (1-1/4" MPT)
20	FG5X12-60 (1-1/4" MPT)
25	FG5X12-80 (1-1/4" MPT)
30	FG10X20-20 (1-1/2" MPT)
35	FG10X20-24 (1-1/2" MPT)
40	FG10X20-30 (1-1/2" MPT)
50	FG10X20-36 (1-1/2" MPT)
60	FG10X20-40 (1-1/2" MPT)
70	FG10X20-50 (2" MPT)
80	FG10X20-60 (2" MPT)
90	FG10X20-60 (2" MPT)
100	FG10X20-70 (2" MPT)
120	FG10X20-80 (2" MPT)
140	FG10X20-100 (2-1/2" MPT)
160	FG10X20-110 (2-1/2" MPT)
180	FG10X20-120 (2-1/2" MPT)
190	FG10X20-130 (2-1/2" MPT)
200	FG10X20-140 (2-1/2" MPT)



Every FlatPlate heat exchanger is equipped with mounting studs, for easier, faster installation with our mounting bracket. Find the right size bracket on page 26.

# Replacing a Shell-And-Tube Heat Exchanger

## Method A. Heat Transfer Surface Method. (Continued)

### Step Six

- The most important item is that the fluid pressure drop of the new installation closely matches (+/- 20%) that of the old shell-and-tube installation, so that the pump performance and fluid flow remains the same.
- Make sure bypass balancing valves are installed on all fluid circuits to the heat exchanger (on both the boiler and secondary side, but excluding steam lines), then adjust for proper pressure drop across the heat exchanger, which matches the pressure drop across the (former) shell-and-tube heat exchanger.
- This ensures a good installation and excellent operation and performance, for high customer satisfaction.

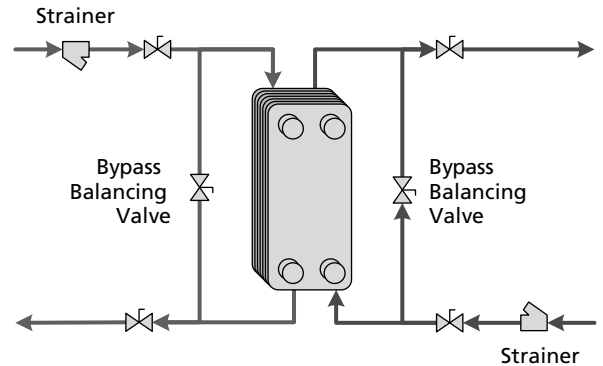

## Method B. Design Condition Method.

The standard design and selection method of a heat exchanger is based on "Design Conditions". This heat exchanger can then be selected from one of the selection charts in this catalog, or online via FlatPlateSelect ([www.flatplateselect.com](http://www.flatplateselect.com)). The information below is required for an online selection.

Note: Five of the Seven starred (\*) lines are needed. Any five will do.

Overall		
Total Heat Transfer*		BTUH or KW
Hot Side (Side A)		
Fluid Type (Always Required)		Water, Water/Glycol Blend (know the glycol percent and type of glycol), other kind of liquid
Temperature In*		Fahrenheit or Celsius
Temperature Out*		Fahrenheit or Celsius
Flow Rate*		Gallons per minute or liters per minute
Max Allowable Pressure Drop (Always Required)		psi or bar
Cold Side (Side B)		
Fluid Type (Always Required)		Water, Water/Glycol Blend (know the glycol percent and type of glycol), other kind of liquid
Temperature In*		Fahrenheit or Celsius
Temperature Out*		Fahrenheit or Celsius
Flow Rate*		Gallons per minute or liters per minute
Max Allowable Pressure Drop (Always Required)		psi or bar

To find a wholesaler near you  
**Call 800-774-0474**  
 Ask for Brazed Technical Support

To run your own detailed selection  
[www.flatplateselect.com](http://www.flatplateselect.com)



To find out more about FlatPlate®  
[www.flatplate.com](http://www.flatplate.com)

# Replacing Another Brand of Brazed Plate Heat Exchanger

## Application

FlatPlate heat exchangers are an easy replacement for several import brands used in a wide range of HVAC/R equipment. All FlatPlate models meet or exceed performance and design pressure ratings of these models.

GEA FlatPlate Models	Replaces SWEP Models	Replaces ALFA-LAVAL Models	Replaces Triangle Tube & Weil McLain Models
FG3X8-14 (3/4" MPT)	B5*14	CB12-14 and CB14-14	TTP1-14E and WMBP1-14E
FG3X8-20 (3/4" MPT)	B5*20	CB12-20 and CB14-20	TTP1-20E and WMBP1-20E
FG3X8-30 (3/4" MPT)	B5*30	CB12-30 and CB14-30	TTP1-30E and WMBP1-30E
FP5X12L-4 (3/4" MPT)	B8*10	CB75-80 and CB76-80	TTP7-80 and WMBP7-80
FP5X12L-6 (3/4" MPT)	B8*10	CB25-6 and CB26-6	TTP1-14E and WMBP1-14E
FP5X12L-8 (3/4" MPT)	B8*16	CB25-8 and CB26-8	TTP1-20E and WMBP1-20E, TTP3-14 and WMBP3-14
FG5X12-10 (3/4" MPT)	B8*20	CB25-12 and CB26-12	TTP4-10 and WMBP4-10
FG5X12-12 (3/4" MPT)	B8*20	CB25-14 and CB26-14	TTP1-30E and WMBP1-30E, TTP3-20 and WMBP3-20
FG5X12-14 (3/4" MPT)	B5*36 and B10*20	CB25-16 and CB26-16	TTP4-14 and WMBP4-14
FG5X12-16 (3/4" MPT)	B8*24	CB25-16 and CB26-16	TTP3-40 and WMBP3-40, TTP4-14 and WMBP4-14
FG5X12-20 (1" MPT)	B8*36 and B10*30	CB25-24 and CB26-24	TTP3-40 and WMBP3-40
FG5X12-24 (1" MPT)	B8*40 and B10*30	CB25-28 and CB26-28	TTP4-24 and WMBP4-24
FP5X12-30 (1" MPT)	B10*40	CB25-34 and CB26-34	TTP4-30 and WMBP4-30
FG5X12-40 (1" MPT)	B10*50	CB25-44 and CB26-44	Not Available
FG5X12-50 (1" MPT)	B10*60	CB25-54 and CB26-54	TTP4-50 and WMBP4-50
FG10X20-20 (1-1/2" MPT)	B45*20 and B50*20	CB25-64 and CB26-64	TTP7-20 and WMBP7-20
FG10X20-24 (1-1/2" MPT)	B45*24 and B50*24	CB75-20 and CB76-20	TTP7-24 and WMBP7-24
FG10X20-30 (1-1/2" MPT)	B45*30 and B50*30	CB75-24 and CB76-24	TTP7-30 and WMBP7-30
FG10X20-40 (1-1/2" MPT)	B45*40 and B50*40	CB75-30 and CB76-30	TTP7-40 and WMBP7-40
FG10X20-50 (2" MPT)	B45*50 and B50*50	CB75-40 and CB76-40	TTP7-50 and WMBP7-50
FG10X20-60 (2" MPT)	B45*60 and B50*60	CB75-50 and CB76-50	TTP7-60 and WMBP7-60
FG10X20-70 (2" MPT)	B45*70 and B50*70	CB75-60 and CB76-60	TTP7-70 and WMBP7-70
FG10X20-80 (2" MPT)	B45*80 and B50*80	CB75-70 and CB76-70	TTP1-14E and WMBP1-14E

## Selection Notes

- Double check the size of the old unit to be sure the FlatPlate heat exchanger will fit in the same space. (See page 25 for dimensions)
- Connection Center Dimensions may not match the dimensions on the old unit.



Every FlatPlate heat exchanger is equipped with mounting studs, for easier, faster installation with our mounting bracket. **Find the right size bracket on page 26.**

To find a wholesaler near you  
**Call 800-774-0474**  
 Ask for Brazed Technical Support

To run your own detailed selection  
[www.flatplateselect.com](http://www.flatplateselect.com)



To find out more about FlatPlate®  
[www.flatplate.com](http://www.flatplate.com)



# Product Dimensions

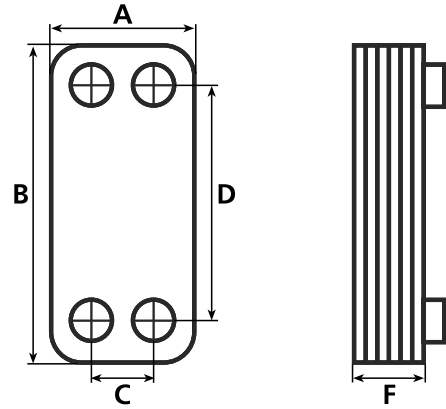

Standard Dimensions											
Model and Size		A		B		C		D		F	
		In	mm	In	mm	In	mm	In	mm	In	mm
FG	3X8	3.4	86	8.9	226	1.7	43	7.2	183	0.40 + (0.087 x N)	10.2 + (2.21 x N)
FG	5X12	5.1	130	13.3	338	2.9	74	11.1	282	0.40 + (0.088 x N)	10.2 + (2.23 x N)
FG	10X20	11.1	282	21.4	544	7.8	198	18.1	460	0.45 + (1.104 x N)	11.4 + (2.36 x N)
FG	10X20L	11.1	282	21.4	544	7.8	198	18.1	460	0.45 + (1.104 x N)	11.4 + (2.36 x N)
FP	5X12L	4.9	124	12.2	310	2.7	69	9.9	251	0.36 + (0.094 x N)	9.14 + (2.39 x N)
FP	10X20L	9.8	249	20.3	516	6.5	165	17.0	432	0.36 + (0.094 x N)	9.14 + (2.39 x N)
FP	15X34AL	15.2	386	34.5	876	9.3	236	28.5	724	0.91 + (0.093 x N)	23.1 + (2.36 x N)
MPN	5X12	4.9	124	12.2	310	2.7	69	9.9	251	0.36 + (0.094 x N)	9.14 + (2.39 x N)
MPN	10X20L	9.8	249	20.3	516	6.5	165	17.0	432	0.36 + (0.094 x N)	9.14 + (2.39 x N)
DW	5X12	5.0	127	13.3	337	2.9	73	11.1	281	0.47 + (0.094 x N)	12.0 + (2.39 x N)
DW	10X20	9.8	249	20.3	516	6.5	165	17.6	432	0.475 + (0.090 x N)	64.76 + (1.02 x N)

Weight and Volume Data								
Model and Size		Net Weight		Volume		Max. Rec. Flow Rate		Max Plate Count
		Pounds	Kilograms	gal/ch	l/ch	gpm	m <sup>3</sup> /h	
FG	3X8	1.74 + (0.12 x N)	0.79 + (0.05 x N)	0.008	0.030	25	6	50
FG	5X12	3.56 + (0.30 x N)	1.61 + (0.14 x N)	0.017	0.065	70	20	120
FG	10X20	29.04 + (1.10 x N)	13.17 + (0.50 x N)	0.061	0.230	200	50	220
FG	10X20L	29.04 + (1.10 x N)	13.17 + (0.50 x N)	0.061	0.230	200	50	220
FP	5X12	2.62 + (0.32 x N)	1.19 + (0.15 x N)	0.017	0.065	70	20	120
FP	10X20L	11.60 + (1.02 x N)	5.26 + (0.46 x N)	0.061	0.230	200	50	200
FP	15X34AL	87.10 + (2.80 x N)	39.51 + (1.27 x N)	0.159	0.600	600	140	360
MPN	5X12	2.62 + (0.32 x N)	1.19 + (0.15 x N)	0.017	0.065	70	20	120
MPN	10X20L	11.60 + (1.02 x N)	5.26 + (0.46 x N)	0.061	0.230	200	50	200
DW	5X12	3.56 + (0.30 x N)	1.61 + (0.14 x N)	0.017	0.065	70	20	100
DW	10X20	36.8 + (1.05 x N)	16.7 + (0.48 x N)	0.061	0.230	200	50	218

**Notes:**

- N = Number of Plates
- ch = channel
- Mass flow rate is based on water at 16 ft/s (5 m/s)



Every FlatPlate heat exchanger is equipped with mounting studs, for easier, faster installation with our mounting bracket. **Find the right size bracket on page 26.**

To find a wholesaler near you  
**Call 800-774-0474**  
 Ask for Brazed Technical Support

To run your own detailed selection  
[www.flatplateselect.com](http://www.flatplateselect.com)



To find out more about FlatPlate®  
[www.flatplate.com](http://www.flatplate.com)

# Accessories to Make Your Life Easier

## Mounting Brackets

### Application

Holding a brazed plate heat exchanger in place while you pipe it up can be a difficult challenge. Piping alignment problems can decrease system efficiency, and cause premature piping failures. FlatPlate makes this easy to prevent. Every FlatPlate brazed plate heat exchanger is equipped as standard with mounting studs which allow the use of our proprietary mounting brackets.

### The FlatPlate Advantage.

With these brackets, installation is easy. Screw the bracket to the floor, then use the mounting studs on the FlatPlate heat exchanger to bolt it to the mounting bracket. This will hold it firmly in place (off the ground) while you pipe it up. The bracket is made of 304 stainless steel, for a durable installation.

The result is a faster, more cost efficient installation, while at the same time guaranteeing a properly aligned piping arrangement.



10X20 Size Shown

What size is your heat exchanger?	Use this Bracket
5X12 (FG, FP or MPN)	BKT5X12
5X20 (FG, FP or MPN)	BKT5X20
10X20 with up to 80 plates (FG, FP or MPN)	BKT10X20
10X20 with 81-200 plates (FG, FP or MPN)	FR10X20

## "Y" Strainer

### Application

It is important to keep the liquid media clean because this reduces fouling and clogging of the FlatPlate heat exchanger. In some cases, it is a requirement for operation of the system. Elsewhere in this catalog, you see strainers included in recommended piping arrangements.

FlatPlate offers quality Y-Strainers designed to filter out particulate contamination.

- Construction material is cast bronze.
- They are rated for working pressure of 400 psig at 150°F.
- Connection at both ends are Female Pipe Thread (FPT).
- The 20 mesh filter is removable and cleanable.



What is your connection size?	Use this Strainer	Flow rate at 1 psi pressure drop	Flow rate at 2 psi pressure drop
3/4"	STR3/4	18 GPM	26 GPM
1"	STR1	28 GPM	40 GPM
1-1/4"	STR1-1/4	42 GPM	60 GPM
1-1/2"	STR1-1/2	70 GPM	100 GPM
2"	STR2	110 GPM	140 GPM
2-1/2"	STR2-1/2	140 GPM	190 GPM
3"	STR3	180 GPM	260 GPM
4"	STR4	300 GPM	420 GPM

## Zinc Anode

### Application

Required in any application where galvanic corrosion is possible.



To find a wholesaler near you

**Call 800-774-0474**

Ask for Braze Technical Support

To run your own detailed selection  
[www.flatplateselect.com](http://www.flatplateselect.com)



To find out more about FlatPlate®  
[www.flatplate.com](http://www.flatplate.com)

# Conversion Formulas and Reference Information

BTU	=	Amount heat required to raise (heat or cool) 1 lb of water 1°F
	=	1054.8 Joules
	=	252 gram-calories
BTU/H	=	Amount of heat over time to raise (heat or cool) 1 lb of water 1°F in ONE hour
BTU/H (water at 68°F)	=	Temp Difference x GPM x 500
BTU/H (30% E. Glycol at 68°F)	=	Temp Difference x GPM x 445
BTU/H (50% E. Glycol at 20°F)	=	Temp Difference x GPM x 375
BTU/H (Most Oils)	=	Temp Difference x GPM x 250
BTU/H (any liquid or gas)	=	$\frac{\text{Temp Difference} \times \text{Specific Heat (BTU/lb}^\circ\text{F)}}{\text{Mass Flow Rate (lbs/hr)}}$
	=	$\frac{\text{Temp Difference} \times \text{Specific Heat (BTU/lb}^\circ\text{F)} \times \text{Density (lb/cu ft)}}{7.4805}$
Celsius (°C)	=	$(^\circ\text{F}-32) \times 5/9$
Conductivity (BTU/hr-ft <sup>2</sup> -°F.ft)	=	°C/cm x .05782
1 Cubic Foot	=	7.481 Gallons
	=	1728 Cubic inches
	=	38.32 liters
Density (lb/cu ft)	=	Specific Gravity x 62.344
	=	g/ml x 62.4
Fahrenheit (°F)	=	$(^\circ\text{C} \times 9/5) + 32$
1 Ft. of Head	=	2.307 psi (lbs per sq inch)
1 Foot of Water (68°F)	=	.4335 psi (lb per sq inch)
	=	.2930 watts
1 Horsepower (boiler)	=	34.5 lb of steam at 212°F
	=	33476 BTU/hr
1 Gallon	=	8.346 lbs of water at 68°F
	=	231 cubic inches
	=	3.785 litres
GPM	=	.060308 Liters/sec
	=	3.62 Liters/min
Kelvin (°K) to °F	=	$\text{K} \times 1.8 - 459.7$
Kilowatt (KW)	=	3414 BTU/hr
1 Lb of Water	=	.01602 Cu Ft
	=	27.68 Cu Inches
	=	.120 gallons
1psi (Pound/sq in)	=	2.307 Feet of water
	=	2.036 inches of Mercury
	=	.06802 Bar (atmospheres)
	=	°R +459.67
Rankin (°R) to °F	=	
Specific Heat (BTU/lb-°F)	=	cal/g-°C x 1
Tank Capacity Calculation (gallons) (rectangular)	=	Length(ft) x Width(ft) x Depth(ft) x 7.481 (gal/cu ft)
Tank Capacity Calculation (gallons) (cylinder)	=	$\frac{\text{Diameter(ft)}^2 \times 3.14 \times \text{Height(ft)} \times 7.481}{4}$ (gal/cu ft)
Tank Heating Total Requirement (BTU total)	=	Tank Temperature Rise x Gallons x 8.346 (plus tank & piping external losses)
Tank Heating Rate (BTU/hr) (Boiler Capacity needed)	=	$\frac{\text{Tank Heating Requirement(BTU)}}{\text{Hrs (hrs desired to bring tank up to temperature)}}$
Tank Heat up Rate (hrs)	=	$\frac{\text{Tank Heating Requirement(BTU)}}{\text{BTU/hr Heat Source Boiler}}$
1 Ton (Refrigeration, chilling)	=	12,000 BTU/hr
1 Ton (Refrigeration. condensing side)	=	15,000 BTU/hr
Viscosity Cp (Centipoise)	=	Centistokes x Density(g/ml)
Viscosity (lb/ft-hr)	=	Cp x 2.42
1 Watt	=	3.413 BTU/hr

To find a wholesaler near you  
**Call 800-774-0474**  
 Ask for Brazed Technical Support

To run your own detailed selection  
[www.flatplateselect.com](http://www.flatplateselect.com)



To find out more about FlatPlate®  
[www.flatplate.com](http://www.flatplate.com)

# Terms and Conditions of Sale

Updates are made available at [www.gea-phe.com/usa](http://www.gea-phe.com/usa)

## 1.1. GENERAL TERMS.

**1.1 Binding Contract.** Unless otherwise noted in the Seller's Proposal, the Proposal shall lapse automatically upon the expiration of a thirty (30) day period after the date of its submission unless it has been previously accepted by Purchaser or revoked in writing by Seller. The Contract incorporating these Terms and Conditions shall not become a binding contract until the Seller receives the Purchaser's unqualified acceptance of the Proposal or the Seller confirms the Purchaser's order in writing.

These Terms and Conditions are the only terms and conditions on which the Seller contracts for the supply of Equipment and they are incorporated in all contracts entered into by the Seller. Any other terms and conditions are hereby specifically rejected and are therefore excluded.

**1.2 Plans, Drawing and Illustrations.** Proposal pages, catalogue illustrations and preliminary drawings are submitted only to show the general style, arrangement, approximate dimensions and weight of equipment. The Seller reserves the right to make such changes of design, construction or arrangement as it deems necessary to achieve the specifications contained herein.

**1.3 Proprietary and Confidential Information.** This Proposal and all drawings, notebooks, operating data, specifications, and other information, data and material (whether orally disclosed, printed, handwritten, typed, numerically or computer generated, computer stored, or otherwise) furnished to Purchaser by either Seller or any of its subcontractors or sub-suppliers shall remain the proprietary and confidential property of Seller or the subcontractor or sub-supplier, respectively, and shall be used by Purchaser only with respect to the work covered by the Contract and shall not be used by Purchaser in connection with any other project. Such proprietary and confidential information and data shall not be shown or otherwise made available to a third party at any time without Seller's prior written consent.

Neither Purchaser itself shall, nor shall Purchaser permit any third party to, reverse engineer, measure or otherwise technically examine or test Seller's Equipment without Seller's prior written consent. Any such proprietary and confidential information which Purchaser determines must be disclosed to its employees shall only be disclosed to them on a need-to-know basis for the operation, maintenance, and repair of the Equipment provided under the Contract. Intellectual property or patent rights which may be obtained on the basis of the information given or made available to Purchaser under the Contract or with respect to Seller's Equipment shall remain the exclusive property of Seller or its subcontractor and/or sub-supplier, respectively.

## 2. SAFETY REQUIREMENTS OF PURCHASER.

Purchaser shall use, and shall train and require its employees to use and shall cause any end user to use, all safety devices, guards, and proper safe operating and maintenance procedures as prescribed by all applicable laws, rules, regulations, codes and standards and as set forth in operating and maintenance manuals and instruction sheets furnished by Seller. Purchaser shall not, and shall cause any end user not to, remove or modify any safety device, guard or warning sign.

If the Purchaser fails to strictly observe any of the obligations set forth in the preceding paragraph with regard to any of the Equipment, Purchaser agrees to defend Seller against, and indemnify and save Seller harmless from, any claim, liability or obligation (including any such federal, state, local or municipal laws, rules, regulations, codes or standards or interpretations thereof) incurred by Seller as a result of persons being injured or property being damaged directly or indirectly in connection with the operation of such Equipment as a result of such failure. Purchaser also agrees to indemnify and save Seller harmless from, any claim, liability or obligation incurred by Seller as a result of persons being injured or property being damaged directly or indirectly in connection with the operation of such Equipment for materials or products not specified in the Contract or use of non-original replacement parts not specifically authorized in writing by Seller or due to changes in the Seller equipment made by Purchaser without Seller's specific written authorization.

## 3. COMPLIANCE WITH LAWS.

The Seller shall use reasonable endeavors to ensure that the Equipment complies in technical respect with the agreed standards and in all other respects with applicable laws, rules, regulations, codes and standards of all federal, state, local and municipal governmental agencies having applicable regulatory jurisdiction, as such laws, rules, regulations, codes and standards are in effect on the date of the contract, provided that: (i) the Purchaser will include in its specifications or will bring to the attention of Seller in writing any state, local or municipal laws, rules, regulations, codes or standards which are different from those imposed by the federal governmental agencies and authorities; (ii) if any such federal, state, local or municipal laws, rules, regulations, codes or standards are changed, or if new laws, regulations, codes or standards or interpretations thereof are enacted or adopted subsequent to the date of the contract, which require a change in Seller's equipment or work, an equitable adjustment shall be made to the contract price, delivery schedule and payment terms; and (iii) Seller shall not be liable for any compliance charges or penalties which Seller incurs in liability for failure of the equipment or work to comply with, any federal, state or local pollution control, effluent or utility control laws, rules, regulations, codes or standards.

## 4. PRICE AND PAYMENT.

**4.1** The purchase price shall be paid in accordance with the Proposal. Any right to retain due payments or to set-off counterclaims shall be excluded unless any such claim or counterclaim of the Purchaser is undisputed by Seller or has been determined by a final judgment of the competent court or arbitration panel.

Any tax or other governmental charge now or hereafter levied upon the production, sale, use or shipment of equipment ordered or sold will be charged to and paid for by the Purchaser. Such taxes are not covered in the Seller's price(s) unless expressly so stated on the Seller's Proposal.

**4.2** Whatever the means of payment used, payment shall not be deemed to have been effected before the Supplier's account has been fully and irrevocably credited.

**4.3** If the Purchaser fails to pay by the stipulated date, the Seller shall be entitled to interest from the day on which payment was due. The rate of interest shall be one and one-half percent (1-1/2%) per month until the payment is made in full. Additionally, if Seller is required to expend costs and expenses in collecting any payments, Purchaser shall reimburse the Seller for such costs of collection (including reasonable attorneys' fees).

In case of late payment the Seller may suspend his performance of the Contract until it receives payment. If the Purchaser has not paid the amount due within three months of the due date, Seller shall be entitled to terminate the Contract by notice in writing to the Purchaser and to claim compensation for the losses and damages it has incurred.

## 5. TRANSPORTATION; INSURANCE; RISK OF LOSS.

### 5.1 Transportation; Delivery.

**5.1.1** Where transportation costs are prepaid, Equipment will be shipped to an unloading point designated by the Purchaser. Unloading and expenses at the designated unloading point and further necessary handling shall be at the Purchaser's risk and expense, independent of any installation services that may be requested by the Purchaser.

**5.1.2** Shipping instructions are to be supplied by the Purchaser at least 10 business days before the agreed on shipping date. In the event Purchaser fails to supply shipping instructions Seller at its option may place the Equipment in Seller's or any public or private storage facilities at the Purchaser's risk and expense. All such expenses shall be invoiced to Purchaser.

**5.1.3** Equipment on which manufacture or delivery is delayed due to any cause within Purchaser's control may be placed in storage by Seller; for the Purchaser's account and risk and repair charges and expenses in connection therewith shall be paid by Purchaser; but if, in Seller's sole opinion, it is unable to obtain or continue such storage, Purchaser will, on request, provide or arrange for suitable storage facilities and assume all

costs and risks in connection therewith. When such delay is due to causes beyond control of either party, the matter of storage and the payment of charges therefore shall be negotiated in good faith.

**5.2** Insurance. Purchaser accepts full responsibility for the safeguarding of all equipment delivered to the Purchaser until it is paid for in full. Until the contract price is paid in full, Purchaser shall provide and maintain insurance to the total value of the Equipment delivered hereunder against all risks of fire and explosion in the names of Purchaser and Seller, as their respective interests may appear, and shall also provide and maintain such insurance to the above value against flood, earthquake, windstorm, cyclone, tornado, hurricanes, riot and strike and civil commotion.

**5.3** Title; Right of Possession; Security for Payment. The parties mutually agree that the Equipment specified herein shall at all times remain personal property regardless of the degree of its annexation to the real property and that the Equipment shall not by reason of any annexation to real property become a part thereof or otherwise a fixture. Title and right of possession of such Equipment shall remain in Seller at all times. Title shall pass to Purchaser in accordance with the delivery terms for the Equipment. Without waiving any rights to elect to proceed under applicable lien laws, Seller reserves a security interest in the equipment and parts furnished by it. By accepting delivery of the Equipment or parts, Purchaser grants to Seller a security interest in such Equipment and parts to secure the full and prompt payment for such Equipment and parts until the agreed price (including any notes therefor) for such Equipment and parts has been fully paid in cash. In the event of default in payment, Seller shall have all rights of repossession and other rights available to a secured party under the laws applicable thereto. Any Equipment or parts may be separated from real estate for purpose of repossession by Seller or by its agent without liability for such removal if the Purchaser is in default in payment. Seller is authorized to execute, deliver and file with the appropriate filing office or offices all assignments, financing statements and other documents which Seller may require to evidence or perfect such security interest in accordance with applicable laws.

## 6. SELLER'S REMEDIES.

**6.1** In the event of a material deterioration of Purchaser's financial situation or in the event of the insolvency of the Purchaser, Seller reserves the right to cancel the contract as well as the right to stop delivery of the goods and to resell same. Such a right shall not restrict or otherwise impair Seller's remedies for damages in the event of Purchaser's breach.

**6.2** Should Purchaser fail to comply with the terms and conditions set forth herein, or if any writ or execution be levied on any of Purchaser's property, or a receiver be appointed, or if a petition in bankruptcy be filed by or against Purchaser, Seller may, upon election, demand the entire purchase price stated herein or may without notice or demand by process of law or otherwise, take possession of all or any of the equipment, wherever located, and retain all monies theretofore paid as compensation for the reasonable use of such equipment. If a contract arising from this Proposal is breached and is placed in the hands of an attorney for collection of any balance due or enforcement of any other of Seller's remedies, Purchaser agrees to pay all reasonable attorney's fees and other expenses involved therein paid or incurred by Seller. Purchaser hereby waives any and all claims, damages and demands against Seller arising out of the repossession, retention and repair as aforesaid. All rights and remedies contained herein are cumulative and not alternative.

**6.3** Seller reserves all other rights and remedies at law or equity available to it in the event of Purchaser's breach.

## 7. ASSIGNMENT.

The Purchaser shall not have the right to assign the agreement without the written consent of Seller.

## 8. SELLER'S LIABILITY; FORCE MAJEURE.

**8.1** Seller shall not be liable for delay or loss or damage of any kind resulting from: (i) Purchaser failing to supply any necessary technical data, as required; (ii) Purchaser failing to supply the apparatus, materials and services required; (iii) any changes in designs or specifications made subsequent to acceptance of this Proposal; (iv) failure of suppliers to furnish purchased material or auxiliary equipment within scheduled dates provided that the purchased material or auxiliary equipment was properly ordered and appropriately expedited; (v) by any other reason beyond Seller's control; or (vi) any delay caused by late payments by Purchaser.

**8.2** Seller shall attempt to overcome but shall not be liable for any loss or delay in delivery of any Equipment or completion of any work as a result of causes of any kind beyond the reasonable control of Seller, including, but not limited to, strikes or other labor difficulties, war, riots, changes in laws and regulations and other acts of governmental authorities, indelible weather, fire, flood or unavoidable casualties, or any delays in transportation of materials, or inability to obtain timely delivery of materials from suppliers, or any delay in transportation or delivery has been properly procured and appropriately expedited. In the event of any such delay, Seller will notify the Purchaser within a reasonable time after Seller becomes aware of such cause of delay and it is agreed that the time for delivery or completion shall be extended for a period of time at least equal to the time lost by reason of the delay.

## 9. MATERIAL AND WORKMANSHIP WARRANTY.

Seller warrants to the Purchaser that the Equipment purchased from Seller is free from defects in material and workmanship. The warranty period shall be twelve (12) months from the date of Purchaser's initial operation using the Equipment but not more than eighteen (18) months from the date of delivery of the Equipment. Any warranty given by the Seller shall be subject to the following: (i) the Equipment is installed in accordance with Seller's specifications and instructions and is used and maintained normally and properly in accordance with Seller's instructions as to maintenance and operation, as set forth in written operation and maintenance manuals and instruction sheets furnished by Seller; (ii) the Equipment has not been changed without the prior written approval of Seller; (iii) Purchaser gives prompt written notice to Seller before the end of the warranty period specifying all alleged defects in the Equipment purchased; and (iv) Purchaser preserves and turns over to Seller and permits reasonable inspection by Seller of all allegedly defective Equipment, parts or items and access to the Equipment to observe its startup, operation and maintenance.

This warranty shall not cover (i) any equipment furnished by Purchaser or any third party (other than a subcontractor of Seller), (ii) any defects arising from corrosion, abrasion, use of unsuitable lubricants, freezing or other operation outside of prescribed temperature ranges, or negligent attendance or faulty operation, (iii) ordinary wear and tear (e.g., gaskets), or (iv) any defects caused by errors on the part of the Purchaser in not providing a suitable place in which the Equipment is to be located, adequate foundation works, or adequate protection against influences within or outside the place where the Equipment is to be located which may affect the Equipment or its operation (improper storage), or (v) the performance of any equipment sold by Seller under conditions varying materially from those under which such equipment is usually tested under existing industry standards. Notwithstanding the warranty set forth above, Seller shall not warrant any equipment, where the vendor of such equipment (other than Seller) is specified by Purchaser, for a period longer than warranted by the vendor.

UNLESS OTHERWISE EXPRESSLY STATED IN ANY DOCUMENT ATTACHED TO THESE TERMS AND CONDITIONS, THIS WARRANTY OF MATERIAL AND WORKMANSHIP IS THE ONLY WARRANTY MADE BY SELLER AND IS IN LIEU OF ALL OTHER WARRANTIES, EXPRESS OR IMPLIED, AND SELLER DISCLAIMS ON BEHALF OF ITSELF, ITS SUBCONTRACTORS AND SUBSUPPLIERS ANY AND ALL WARRANTIES, INCLUDING, WITHOUT LIMITATION, WARRANTIES OF MERCHANTABILITY, FITNESS FOR A SPECIFIC PURPOSE (OTHER THAN THE PURPOSE STATED IN THE PURCHASER'S SPECIFICATIONS SET FORTH IN THE CONTRACT), SUITABILITY OR PERFORMANCE. No other promise or affirmation of fact (including, but not limited to, statements regarding capacity or performance of the Equipment) shall constitute a warranty of Seller or give rise to any liability or obligation on the part of Seller.

Seller's obligation under this warranty and any other warranty or guarantee which is part of the Contract is strictly and exclusively limited to furnishing repairs or replacements for Equipment or parts determined to be defective on inspection by an authorized representative of Seller. Notwithstanding this exclusive remedy, if it is ultimately determined that the remedy fails in its essential purpose, then any action which may be brought against Seller subject to the terms of the contract will be limited to 100% of the contract price for the purchased Equipment for which the exclusive remedy has so failed. Seller assumes no responsibility and shall have no liability for any repairs or replacements by Purchaser without Seller's prior written authorization. If Seller did not originally install the Equipment, Seller shall have no liability for the costs of removing or segregating any defective Equipment so that the repairs or replacements can be made. If tests are requested by the Purchaser to determine the performance of the Equipment covered in the Seller's Proposal, the test procedure to be used must be acceptable to the Seller, and the Purchaser agrees to pay to the Seller the cost of any such test.

## 10. DAMAGES.

NOTWITHSTANDING ANY OTHER PROVISION OF THE CONTRACT TO THE CONTRARY:

**(A)** SELLER'S AND ITS SUBCONTRACTORS' AND SUBSUPPLIERS' AGGREGATE RESPONSIBILITY AND LIABILITY, WHETHER ARISING OUT OF CONTRACT OR TORT OR ANY OTHER LEGAL CONTEXT OR THEORY, INCLUDING NEGLIGENCE AND CONSEQUENTIAL DAMAGES, UNDER THE CONTRACT, INCLUDING, BUT NOT LIMITED TO, ALL CLAIMS FOR BREACH OF ANY WARRANTY OR GUARANTEE, FAILURE OF PERFORMANCE OR DELAY IN PERFORMANCE BY SELLER OR PERFORMANCE OR NON-PERFORMANCE OF THE PURCHASED EQUIPMENT SHALL NOT EXCEED THE CONTRACT PRICE FOR THE PURCHASED EQUIPMENT, PROVIDED, HOWEVER, THAT THIS LIMITATION WILL NOT APPLY TO ANY LIABILITY OF SELLER FOR DIRECT DAMAGES CLAIMED BY PURCHASER FOR PHYSICAL DAMAGE TO PURCHASER'S PROPERTY (OTHER THAN EQUIPMENT PROVIDED BY SELLER) OR FOR DIRECT DAMAGES CLAIMED BY THIRD PARTIES FOR SUCH THIRD PARTIES' PERSONAL INJURY OR PHYSICAL PROPERTY DAMAGE (FOR WHICH PURCHASER IS LIABLE TO THE EXTENT CAUSED BY THE NEGLIGENCE ACTS OR OMISSIONS OR WILLFUL MISCONDUCT OF THE SELLER, FOR ALL OF WHICH MATTERS SELLER SHALL BE LIABLE UP TO AN AMOUNT OF \$1,000,000 IN THE AGGREGATE, AND

**(B)** IN NO EVENT SHALL SELLER, ITS SUBCONTRACTORS OR SUBSUPPLIERS BE LIABLE IN CONTRACT OR IN TORT OR UNDER ANY OTHER LEGAL CONTEXT OR THEORY, INCLUDING NEGLIGENCE AND STRICT LIABILITY, FOR ANY SPECIAL, PUNITIVE, INDIRECT, INCIDENTAL OR CONSEQUENTIAL DAMAGES, OF ANY KIND OR CHARACTER, INCLUDING, BUT NOT LIMITED TO, LOSS OF USE OF PRODUCTIVE FACILITIES OR EQUIPMENT, COSTS OF PRODUCT RECALL, PLANT DOWNTIME, DAMAGE TO OR LOSS OF PRODUCT, CHEMICALS, CATALYSTS, FEEDSTOCK OR OTHER RAW MATERIALS, LOSS OF REVENUES OR PROFITS OR LOSS UNDER PURCHASES OR CONTRACTS MADE IN RELIANCE ON THE PERFORMANCE OR NON-PERFORMANCE OF THE PURCHASED EQUIPMENT, WHETHER SUFFERED BY PURCHASER OR ANY THIRD PARTY, OR FOR ANY LOSS OR DAMAGE ARISING OUT OF THE SOLE OR CONTRIBUTORY NEGLIGENCE OF THE PURCHASER, ITS EMPLOYEES OR AGENTS OR ANY THIRD PARTY.

TO THE EXTENT THAT SELLER OR THE PURCHASER MAKES ANY CLAIM UNDER ANY FRAUD OR TORT THEORY FOR THE PURPOSE OF CIRCUMVENTING THE LIMITATIONS AND DISCLAIMERS SET FORTH ABOVE AND IS UNSUCCESSFUL IN PROSECUTING SUCH CLAIMS, IT HEREBY AGREES TO REIMBURSE AND INDEMNIFY THE OTHER PARTY FOR ALL ATTORNEYS' FEES AND EXPENSES AND COSTS INCURRED BY THE OTHER PARTY IN DEFENDING SUCH CLAIM.

## 11. ALTERATION - MODIFICATION.

No waiver, alteration or modification of these Terms and Conditions, except as noted in the text of the Proposal shall be valid unless made in writing and signed by an authorized representative of Seller.

## 12. PATENTS.

Seller shall hold Purchaser harmless against any claim that Seller's Equipment infringes United States apparatus patents, but Seller makes no representation or warranty, and Seller shall have no responsibility for any infringement or unfair competition resulting from, the use of Seller's Equipment with the Purchaser's process, or in combination with other equipment not supplied by Seller.

## 13. PRODUCT SELECTION AND USE.

Notwithstanding Seller's warranty obligations pursuant to these General Terms and Conditions of Sale, the Purchaser shall be responsible for accurate design and operating conditions in the selection and use of the Seller's products. The Purchaser's selection and use of Seller's products from published literature shall be at the Purchaser's risk as to appropriate application, design conditions and performance criteria use.

## 14. STANDARDS AND TOLERANCES.

All product dimensions and published information is subject to change without notice. All of Seller's products furnished to the Purchaser shall also be subject to tolerances and variations consistent with usages of the trade concerning dimensions, composition and mechanical properties and normal variations in performance characteristics and quality.

## 15. INTEGRATION CLAUSE.

Purchaser acknowledges (1) that the Contract may not be modified or terminated except in writing signed by a duly authorized representative of Seller making specific reference to the Contract, and (2) the Purchaser may not assign the contract without the prior written consent of Seller.

## 16. DISPUTE RESOLUTION; GOVERNING LAW

Any determination, agreement or performance which is disputed or cannot be made, resolved or agreed within fourteen (14) days of the date requested by either Purchaser or Seller or such longer period for resolution as may be mutually agreed shall be submitted for resolution by the chief executive officers of the Purchaser and Seller. It shall be a condition precedent to any subsequent proceeding that the dispute shall be submitted for resolution by such chief executive officers, but if those officers shall not reach a resolution within twenty-one (21) days of submittal to them, then the matter shall be finally settled by arbitration under the Rules of the American Arbitration Association by one or more arbitrators appointed in accordance with such Rules. The place of arbitration will be Philadelphia, Pennsylvania. The contract between the Seller and the Purchaser and their respective performances shall be construed under and governed by the laws of Pennsylvania.

## 17. DEFINITIONS

In these Terms and Conditions:

"Contract" means the contract between the Seller and the Purchaser for the supply of Equipment which will comprise these Terms and Conditions, the Seller's Proposal, any documents referred to in the Proposal as forming part of the contract, the Purchaser's order and the Seller's confirmation of that order (or the Purchaser's unqualified acceptance of the Proposal);

"Equipment" means the equipment, goods and materials to be supplied to the Purchaser under the Contract;

"Proposal" means the Seller's written proposal to the Purchaser for the supply of the Equipment;

"Purchaser" means the person identified as the purchaser of the Equipment in the Proposal and the Contract;

"Seller" means GEA PHE Systems North America, Inc.