

Hydronic Product & Application Catalog

FlatPlate[®] By GEA PHE Systems NA, Inc.

- Radiant Floor Heating
- Domestic Water Heating
- Snow Melt
- Swimming Pools
- Steam
- Close Approach
- High Pressure Systems
- Multi-Purpose
- Shell and Tube Replacements



Brazed Plate Heat Exchangers



Process Equipment Division
GEA PHE Systems NA, Inc.

Standard Applications

Selection Guide

Application:	Product:	Page:
Water	FP	4 thru 7
Glycols	FP	4 thru 7
Radiant Floor Heating	FP	10 & 11
Domestic Hot Water	FP	12 & 13
Domestic Hot Water / Double Wall	DW	14 & 15
Swimming Pools & Spas	MPN	16 & 17
Snow Melt	FP	18
Close Approach		19 & 20
Shell and Tube Replacement	FP	21 & 22
BPHE Replacements		23
Accessories		24 & 25

Special Applications

Selection Guide

Application:	Product:	Page:
De-Ionized Water	FPN	4 thru 7
Hydraulic Oils	FP	4 thru 7
SAE Oils	FP	4 thru 7
Cooling Tower Water	FP	4 thru 7
Beer	FP	4 thru 7
Wine & Alcohols	FPN	4 thru 7
Ammonia	FPA	Consult Factory
Steam (treated & untreated)	MPN	8 & 9
Steam Condensate	MPN	8 & 9
Brackish Process Water	MPN	8 & 9
Low PH Acid Concentrations	MPN	8 & 9
Calcium Chloride	MPN	8 & 9
Solvents (Low PH)	MPN	8 & 9
Fish Tanks	MPN	8 & 9
River Water	MPN	8 & 9
Ground Water	MPN	8 & 9

Hydronic Heat Exchangers

21ST Century Technology

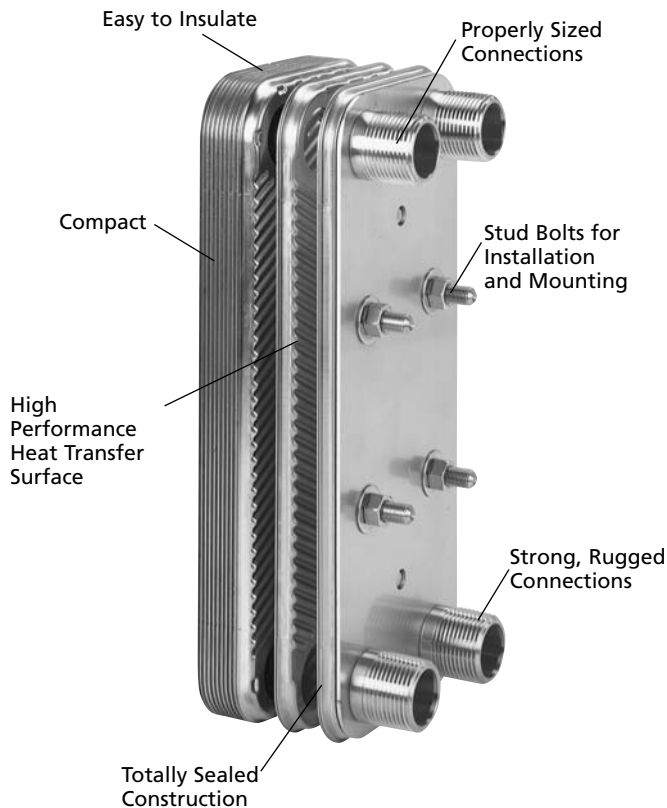

Proven Performance

Unique to FlatPlate® is exacting performance and expertise from the factory. In this catalog there are select models specifically designed for Hydronic heating, steam, and process heating/cooling. *FlatPlate® designs have been tested for proven performance and can be computer selected for a wide range of operating conditions, fluids, and applications.*

A History of Reliability

Braze plate heat exchangers have a solid background and have evolved from 60 years of plate heat exchanger technology. With FlatPlate®, all models have field proven reliability and important features built-in. FlatPlate® is the leading innovator in the U.S. of this technology for hydronics and refrigeration.

Working Temperatures: -320°F to 350°F
Working Pressures: up to 450 psi
Approvals: U.L. Listed
ASME Certified (optional)
Canadian CRN
CE (optional)

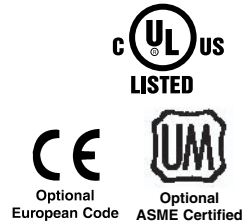

Simply Effective

FlatPlate®'s Brazed Plate Heat Exchangers consist of 4 to 200 specially formed stainless steel plates, which are then copper brazed together in a vacuum furnace for leak tight, rugged construction. When stacked, the plates form two separate flow passages between the plates, thus allowing a liquid to flow between every other plate. This provides heat transfer and complete separation of the fluids and gases. With FlatPlate®'s high performance heat transfer surface, a very compact, cost effective design is the result.

Four Reasons to Use GEA's Brazed Products

GEA PHE Systems heat exchangers have significant advantages.

1. **Smaller Size** - GEA PHE Systems heat exchangers are 20% to 60% smaller than traditional shell & tube and coaxial type devices. This means they use less space, weigh less and require less refrigerant charge.
2. **Higher Performance** - Plate heat exchangers have higher heat transfer coefficients. This means improved performance and greater versatility for standard applications, high viscosity fluids and special design conditions. In addition, lower fouling rates contribute to long life efficiency.
3. **Lower Cost** - GEA PHE Systems heat exchangers cost 10% to 30% less than other types of comparable heat exchangers. Installation costs are also lower.
4. **Customer Service** - We provide customer service, computer selections, and excellent technical support.

FP Series

Hydronic



The FP Series is designed specifically for Hydronic Heating, Industrial Process, Boiler applications, Domestic Water Heating, Snow Melt, Steam, Fluid to Fluid applications, and Shell/Tube replacements. The FP Series is rugged and reliable, yet very compact, representing the latest technology in high performance heat exchangers. Copper brazed, stainless steel plates offer a highly efficient, low fouling heat transfer surface. All FP units have male pipe thread fittings and mounting stud bolts are standard. Other connections available by special order. U. L. Listed. Optional ASME and (CE) European PED code approvals.

<i>3"x8" Models</i>	No. of	Width	Length	Depth	Connections	GPM @ 5.0 psig PD		Weight
	Plates	(inches)	(inches)	(inches)	MPT	Side-A	Side-B	(lbs)
FP3x8-14 (3/4" MPT)	14	3.3	7.8	1.6	3/4"	8.1	8.9	3.2
FP3x8-20 (3/4" MPT)	20	3.3	7.8	2.1	3/4"	11.3	11.7	3.9
FP3x8-30 (3/4" MPT)	30	3.3	7.8	3.0	3/4"	15.0	15.1	4.9

<i>5"x12" Models</i>	No. of	Width	Length	Depth	Connections	GPM @ 5.0 psig PD		Weight
	Plates	(inches)	(inches)	(inches)	MPT	Side-A	Side-B	(lbs)
FP5X12-4 (3/4" MPT)	4	4.9	12.2	0.7	3/4"	1.5	2.8	4.5
FP5X12-6 (3/4" MPT)	6	4.9	12.2	0.9	3/4"	2.9	4.2	5.1
FP5X12-8 (3/4" MPT)	8	4.9	12.2	1.1	3/4"	4.3	5.6	5.8
FP5X12-10 (3/4" MPT)	10	4.9	12.2	1.3	3/4"	6.3	7.9	6.4
FP5X12-12 (3/4" MPT)	12	4.9	12.2	1.5	3/4"	7.9	9.4	7.0
FP5X12-14 (3/4" MPT)	14	4.9	12.2	1.7	3/4"	9.5	11.0	7.7
FP5X12-16 (3/4" MPT)	16	4.9	12.2	1.9	3/4"	11.0	12.6	8.3
FP5X12-20 (1" MPT)	20	4.9	12.2	2.2	1"	14.1	15.5	9.6
FP5X12-24 (1" MPT)	24	4.9	12.2	2.6	1"	17.1	18.5	10.8
FP5X12-30 (1" MPT)	30	4.9	12.2	3.2	1"	21.0	22.0	12.7
FP5X12-30 (1-1/4" MPT)	30	4.9	12.2	3.2	1-1/4"	25.0	26.0	12.7
FP5X12-36 (1" MPT)	36	4.9	12.2	3.7	1"	25.0	27.0	14.6
FP5X12-40 (1" MPT)	40	4.9	12.2	4.1	1"	28.0	29.0	15.9
FP5X12-40 (1-1/4" MPT)	40	4.9	12.2	4.1	1-1/4"	32.0	33.0	15.9
FP5X12-50 (1" MPT)	50	4.9	12.2	5.1	1"	34.0	35.0	19.0
FP5X12-50 (1-1/4" MPT)	50	4.9	12.2	5.1	1-1/4"	38.0	39.0	19.0
FP5X12-60 (1-1/4" MPT)	60	4.9	12.2	6	1-1/4"	40.0	41.0	22.2
FP5X12-70 (1-1/4" MPT)	70	4.9	12.2	6.9	1-1/4"	45.0	46.0	25.3
FP5X12-80 (1-1/4" MPT)	80	4.9	12.2	7.9	1-1/4"	49.0	50.0	28.5

<i>5"x12L" Models</i>	No. of	Width	Length	Depth	Connections	GPM @ 5.0 psig PD		Weight
	Plates	(inches)	(inches)	(inches)	MPT	Side-A	Side-B	(lbs)
FP5X12L-4 (3/4" MPT)	4	4.9	12.2	0.7	3/4"	3.2	5.8	4.5
FP5X12L-6 (3/4" MPT)	6	4.9	12.2	0.9	3/4"	6.5	9.4	5.1
FP5X12L-8 (3/4" MPT)	8	4.9	12.2	1.1	3/4"	9.8	11.6	5.8
FP5X12L-10 (1" MPT)	10	4.9	12.2	1.3	1"	13.2	15.5	6.4
FP5X12L-12 (1" MPT)	12	4.9	12.2	1.5	1"	16.4	18.6	7.0
FP5X12L-14 (1" MPT)	14	4.9	12.2	1.7	1"	19.5	21.6	7.7
FP5X12L-16 (1" MPT)	16	4.9	12.2	1.9	1"	22.7	24.5	8.3
FP5X12L-20 (1-1/4" MPT)	20	4.9	12.2	2.2	1-1/4"	28.5	30.0	9.6
FP5X12L-24 (1-1/4" MPT)	24	4.9	12.2	2.6	1-1/4"	34.0	35.0	10.8
FP5X12L-30 (1" MPT)	30	4.9	12.2	3.2	1"	41.0	42.0	12.7
FP5X12L-30 (1-1/4" MPT)	30	4.9	12.2	3.2	1-1/4"	41.0	42.0	12.7
FP5X12L-36 (1-1/4" MPT)	36	4.9	12.2	3.7	1-1/4"	47.0	48.0	14.6
FP5X12L-40 (1-1/4" MPT)	40	4.9	12.2	4.1	1-1/4"	52.0	52.0	15.9
FP5X12L-50 (1-1/4" MPT)	50	4.9	12.2	5.1	1-1/4"	60.0	60.0	19.0
FP5X12L-60 (1-1/4" MPT)	60	4.9	12.2	6	1-1/4"	65.0	65.0	22.2
FP5X12L-70 (1-1/4" MPT)	70	4.9	12.2	6.9	1-1/4"	70.0	70.0	25.3
FP5X12L-80 (1-1/4" MPT)	80	4.9	12.2	7.9	1-1/4"	73.0	73.0	28.5

For ASME versions, put "-UM" after the model number; Example FP5x12-20 (1" MPT)-UM

For International versions, corrections are BSPT; Example FP5x12-20 (1-1/4" BSPT)

Design Pressure Ratings:

FP3x8 and FP5x12 models are 450 psig.

FP5x12L models are 300 psig.

FP Series

Hydronic

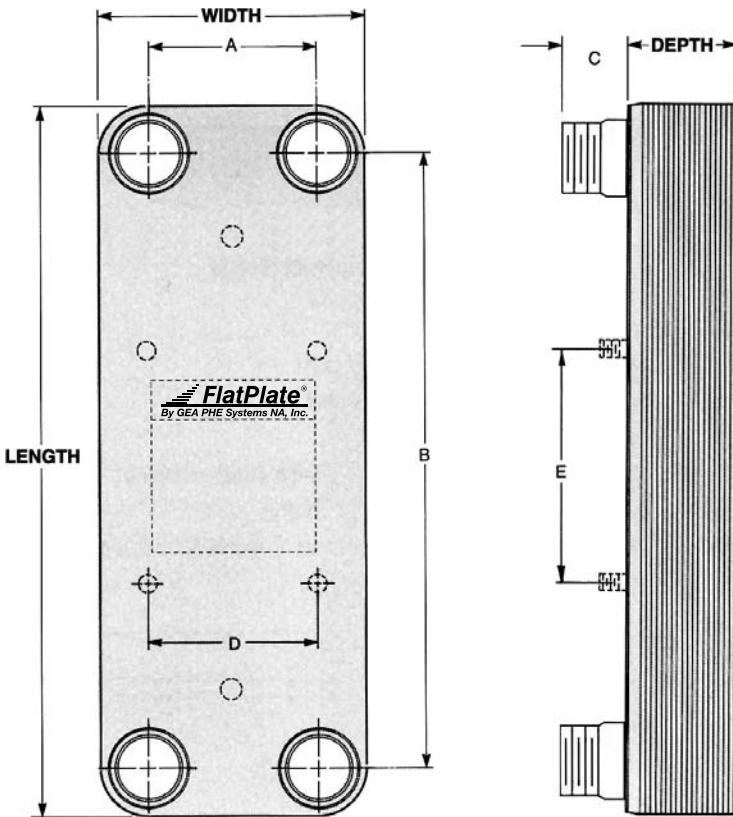



Connections (a)		
# of Plates	Standard	C
	Threaded (MPT)	
3X8 Models		
4 and 6	1/2"	1.000
8 thru 50	3/4"	1.000
5X12 Models		
4 thru 16	3/4"	1.125
20 thru 30, 36	1"	1.250
40 and 50		
30, 40 and 50 thru 120	1-1/4"	1.375
5X12L Models		
4 thru 8	3/4"	1.125
10 thru 16, 30	1"	1.250
20, 24 and 30 thru 120	1-1/4"	1.375

- (a) Connections the same on both sides
- (b) Heat exchanger may be installed in vertical or horizontal position (except steam application)
- (c) Heat exchanger must be piped in counterflow arrangement
- (d) A water strainer **MUST** be installed in the water inlet circuit (16-20 mesh minimum, 20-40 mesh recommended)
- (e) Water quality should be maintained at a PH of 6.5 to 8.0
- (f) Use MPN Marine Series for steam, chlorinated water and pool water applications

Stud Bolts:

- 1/4-20 x 11/16"L on all 3 x 8 Models
- 3/8-24 x 7/8"L on all 5 x 12 Models

Models	Length	Width	Depth	A	B	C (Min)	C (Max)	D	E	Approximate Weight (lbs)
	(inches)	(inches)	(inches)	(inches)						
FP3X8	7.8	3.3	0.094 x #plates + 0.36	1.6	6.1	0.88	1.00	C/L	3.0	0.107 x #plates + 1.8
FP5X12	12.2	4.9	0.094 x #plates + 0.36	2.7	9.9	1.13	1.38	2.5	3.5	0.328 x #plates + 3.1
FP5X12L										

  	Specifications	
	Plate Material: 316L Stainless Steel Braze Material: Copper Maximum Working Temperature: 350°F Minimum Working Temperature: -320°F Maximum Working Pressure: 450 psig FP5x12, FP3x8 300 psig (FP5x12L)	<ul style="list-style-type: none"> • Approvals: <ul style="list-style-type: none"> U.L. (Underwriters Laboratory) USA and Canada-standard ASME Certification (optional) Canadian CRN CE (optional) • Optional Floor Mount Brackets and Strainers • Standard and Custom units available including Nickel brazed, FPN (300psi) versions.

FP Series

Hydronic



<i>10"x20" Models</i>	No. of	Width	Length	Depth	Connections	GPM @ 7.5 psig PD		Weight
	Plates	(inches)	(inches)	(inches)	MPT	Side-A	Side-B	(lbs)
FP10X20-20 (1-1/2" MPT)	20	9.8	20.3	2.2	1-1/2"	25.6	27.5	33
FP10X20-24 (1-1/2" MPT)	24	9.8	20.3	2.6	1-1/2"	31.3	33.0	37
FP10X20-30 (1-1/2" MPT)	30	9.8	20.3	3.2	1-1/2"	39.6	41.0	44
FP10X20-36 (1-1/2" MPT)	36	9.8	20.3	3.7	1-1/2"	48.0	49.0	50
FP10X20-40 (1-1/2" MPT)	40	9.8	20.3	4.1	1-1/2"	53.5	54.5	55
FP10X20-50 (2" MPT)	50	9.8	20.3	5.1	2"	67.0	67.5	66
FP10X20-60 (2" MPT)	60	9.8	20.3	6.0	2"	80.0	80.0	77
FP10X20-70 (2" MPT)	70	9.8	20.3	6.9	2"	93.0	93.0	88
FP10X20-80 (2" MPT)	80	9.8	20.3	7.9	2"	105.0	105.0	99
FP10X20-90 (2-1/2" MPT)	90	9.8	20.3	8.8	2-1/2"	117.0	117.0	110
FP10X20-100 (2-1/2" MPT)	100	9.8	20.3	9.8	2-1/2"	128.0	128.0	121
FP10X20-110 (2-1/2" MPT)	110	9.8	20.3	10.7	2-1/2"	139.0	139.0	132
FP10X20-120 (2-1/2" MPT)	120	9.8	20.3	11.6	2-1/2"	149.0	149.0	143
FP10X20-130 (2-1/2" MPT)	130	9.8	20.3	12.6	2-1/2"	158.0	158.0	154
FP10X20-140 (2-1/2" MPT)	140	9.8	20.3	13.5	2-1/2"	168.0	168.0	165
FP10X20-150 (2-1/2" MPT)	150	9.8	20.3	14.5	2-1/2"	176.0	176.0	176
FP10X20-160 (2-1/2" MPT)	160	9.8	20.3	15.4	2-1/2"	184.0	184.0	187
FP10X20-170 (2-1/2" MPT)	170	9.8	20.3	16.3	2-1/2"	192.0	192.0	198
FP10X20-180 (2-1/2" MPT)	180	9.8	20.3	17.3	2-1/2"	200.0	200.0	209
FP10X20-190 (2-1/2" MPT)	190	9.8	20.3	18.2	2-1/2"	206.0	206.0	220
FP10X20-200 (2-1/2" MPT)	200	9.8	20.3	19.2	2-1/2"	212.0	212.0	231

<i>10"x20L" Models</i>	No. of	Width	Length	Depth	Connections	GPM @ 7.5 psig PD		Weight
	Plates	(inches)	(inches)	(inches)	MPT	Side-A	Side-B	(lbs)
FP10X20L-20 (1-1/2" MPT)	20	9.8	20.3	2.2	1-1/2"	62.5	66.0	33
FP10X20L-24 (1-1/2" MPT)	24	9.8	20.3	2.6	1-1/2"	75.5	78.5	37
FP10X20L-30 (2" MPT)	30	9.8	20.3	3.2	2"	94.5	97.0	44
FP10X20L-36 (2" MPT)	36	9.8	20.3	3.7	2"	112.5	114.0	50
FP10X20L-40 (2" MPT)	40	9.8	20.3	4.1	2"	124.0	125.0	55
FP10X20L-50 (2-1/2" MPT)	50	9.8	20.3	5.1	2-1/2"	150.0	150.0	66
FP10X20L-60 (2-1/2" MPT)	60	9.8	20.3	6.0	2-1/2"	174.0	174.0	77
FP10X20L-70 (2-1/2" MPT)	70	9.8	20.3	6.9	2-1/2"	193.0	193.0	88
FP10X20L-80 (2-1/2" MPT)	80	9.8	20.3	7.9	2-1/2"	211.0	211.0	99
FP10X20L-90 (2-1/2" MPT)	90	9.8	20.3	8.8	2-1/2"	224.0	224.0	110
FP10X20L-100 (2-1/2" MPT)	100	9.8	20.3	9.8	2-1/2"	236.0	236.0	121
FP10X20L-110 (2-1/2" MPT)	110	9.8	20.3	10.7	2-1/2"	249.0	249.0	132
FP10X20L-120 (2-1/2" MPT)	120	9.8	20.3	11.6	2-1/2"	256.0	256.0	143
FP10X20L-130 (2-1/2" MPT)	130	9.8	20.3	12.6	2-1/2"	265.0	265.0	154
FP10X20L-140 (2-1/2" MPT)	140	9.8	20.3	13.5	2-1/2"	272.0	272.0	165
FP10X20L-150 (2-1/2" MPT)	150	9.8	20.3	14.5	2-1/2"	277.0	277.0	176
FP10X20L-160 (2-1/2" MPT)	160	9.8	20.3	15.4	2-1/2"	283.0	283.0	187
FP10X20L-170 (2-1/2" MPT)	170	9.8	20.3	16.3	2-1/2"	287.0	287.0	198
FP10X20L-180 (2-1/2" MPT)	180	9.8	20.3	17.3	2-1/2"	291.0	291.0	209
FP10X20L-190 (2-1/2" MPT)	190	9.8	20.3	18.2	2-1/2"	295.0	295.0	220
FP10X20L-200 (2-1/2" MPT)	200	9.8	20.3	19.2	2-1/2"	301.0	301.0	231

For ASME versions, put "-UM" after the model number; Example FP10x20-20 (1-1/2" MPT)-UM
 For International versions, corrections are BSPT; Example FP10x20-20 (1-1/2" BSPT)

FP Series

Hydronic

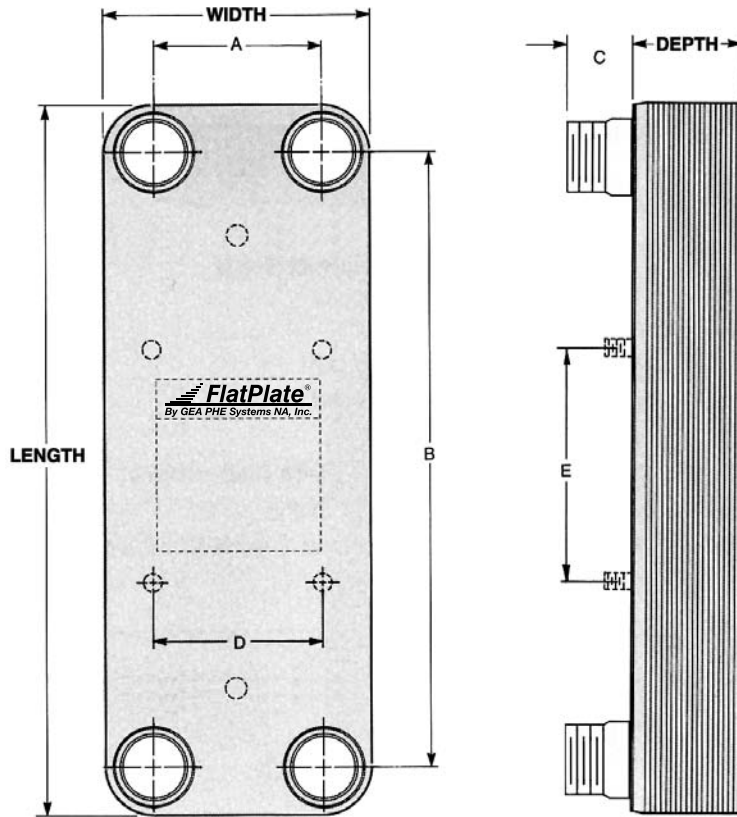



Connections (a)		
# of Plates	Standard	C
	Threaded (MPT)	
10X20 Models		
20 thru 40	1-1/2"	1.500
50 thru 80	2"	1.750
90 thru 200	2-1/2"	2.000
10X20L Models		
20 and 24	1-1/2"	1.500
30 thru 40	2"	1.750
50 thru 200	2-1/2"	2.000

- (a) Connections the same on both sides
- (b) Heat exchanger may be installed in vertical or horizontal position (except steam application)
- (c) Heat exchanger must be piped in counterflow arrangement
- (d) A water strainer **MUST** be installed in the water inlet circuit (16-20 mesh minimum, 20-40 mesh recommended)
- (e) Water quality should be maintained at a PH of 6.5 to 8.0
- (f) Use MPN Marine Series for steam, chlorinated water and pool water applications

Stud Bolts:

- 1/2-13 x 1-3/8" L standard on all 10 x 20 Models

Models	Length	Width	Depth	A	B	C (Min)	C (Max)	D	E	Approximate Weight (lbs)
	(inches)	(inches)	(inches)	(inches)						
FP10X20	20.3	9.8	0.094 x #plates + 0.36	6.5	17.0	1.50	2.00	4.0	5.5	1.1 x #plates + 10.7
FP10X20L										

  	<h3>Specifications</h3> <p>Plate Material: 316L Stainless Steel Braze Material: Copper Maximum Working Temperature: 350°F Minimum Working Temperature: -320°F Maximum Working Pressure: 450 psi</p>
	<ul style="list-style-type: none"> • Approvals: <ul style="list-style-type: none"> U.L. (Underwriters Laboratory) USA and Canada-standard ASME Certification (optional) Canadian CRN CE (optional) • Optional Floor Mount Brackets and Strainers • Standard and Custom units available including Nickel brazed, FPN (300psi) versions.

MPN Series

Swimming Pool



The MPN Series is designed specifically for Swimming Pool applications, where chlorine, biological elements or low concentrations of acids are present. The MPN Series is rugged, yet very compact, representing the latest technology in corrosion resistant plate heat exchangers. It's Nickel brazed, 254SMO Stainless Alloy plates offer significant improvements in reliability over traditional stainless materials and has high efficiency heat transfer for applications up to 200 gpm per unit. All MPN Series models have male pipe thread fittings and mounting stud bolts. Maximum allowable working pressure, 300 psig.

MPN Series applications include:

Swimming Pool

- Swimming Pool to Boiler
- Swimming Pool to Heat Pump Water Loop

Process

- Brackish Water
- Treated Steam to Fluid
- Steam Condensate to Fluid
- Cooling Tower Water
- Low Acid Concentrations

<i>5"x12" Models</i>	No. of	Width	Length	Depth	Connections	GPM @ 5.0 psig		GPM @ 7.5 psig		Net Wt.
	Plates	(inches)	(inches)	(inches)	Side A & B	Side-A	Side-B	Side-A	Side-B	(lbs)
MPN5X12-4 (1" MPT)	4	4.9	12.2	0.7	1" MPT	1.1	2.1	1.6	3.1	14.7
MPN5X12-6 (1" MPT)	6	4.9	12.2	0.9	1" MPT	2.1	3.1	3.2	4.7	15.5
MPN5X12-8 (1" MPT)	8	4.9	12.2	1.0	1" MPT	3.2	4.2	4.8	6.4	16.2
MPN5X12-10 (1" MPT)	10	4.9	12.2	1.2	1" MPT	4.2	5.2	6.4	8.0	16.9
MPN5X12-16 (1" MPT)	16	4.9	12.2	1.7	1" MPT	7.3	8.3	11.1	12.7	19.1
MPN5X12-20 (1-1/4" MPT)	20	4.9	12.2	2.0	1" MPT	9.3	10.3	14.2	15.7	20.6
MPN5X12-24 (1-1/4" MPT)	24	4.9	12.2	2.4	1-1/4" MPT	11.3	12.3	17.3	18.7	22.1
MPN5X12-30 (1-1/4" MPT)	30	4.9	12.2	2.9	1-1/4" MPT	16.6	17.5	25.3	26.7	24.3
MPN5X12-40 (1-1/4" MPT)	40	4.9	12.2	3.7	1-1/4" MPT	18.9	19.7	28.8	30.0	28.0
MPN5X12-50 (1-1/4" MPT)	50	4.9	12.2	4.6	1-1/4" MPT	25.4	26.0	38.7	39.7	31.6
MPN5X12-60 (1-1/4" MPT)	60	4.9	12.2	5.4	1-1/4" MPT	26.6	27.3	40.6	41.6	35.3
MPN5X12-70 (1-1/4" MPT)	70	4.9	12.2	6.3	1-1/4" MPT	29.8	30.5	45.5	46.5	39.0
MPN5X12-80 (1-1/4" MPT)	80	4.9	12.2	7.1	1-1/4" MPT	33.0	33.4	50.3	50.9	42.7

<i>10"x20" Models</i>	No. of	Width	Length	Depth	Connections	GPM @ 5.0 psig		GPM @ 7.5 psig		Net Wt.
	Plates	(inches)	(inches)	(inches)	Side A & B	Side-A	Side-B	Side-A	Side-B	(lbs)
MPN10X20L-20 (1-1/2" MPT)	20	9.8	20.3	2.2	1-1/2" MPT	50.0	53.0	62.0	66.0	32.7
MPN10X20L-24 (1-1/2" MPT)	24	9.8	20.3	2.6	1-1/2" MPT	61.0	63.5	75.0	78.0	37.1
MPN10X20L-30 (2" MPT)	30	9.8	20.3	3.2	2" MPT	76.0	78.5	94.0	97.0	43.7
MPN10X20L-36 (2" MPT)	36	9.8	20.3	3.7	2" MPT	91.0	92.0	112.0	114.0	50.3
MPN10X20L-40 (2" MPT)	40	9.8	20.3	4.1	2" MPT	100.0	101.0	124.0	125.0	54.7
MPN10X20L-50 (2-1/2" MPT)	50	9.8	20.3	5.1	2-1/2" MPT	121.0	121.0	149.0	150.0	65.7
MPN10X20L-60 (2-1/2" MPT)	60	9.8	20.3	6.0	2-1/2" MPT	141.0	141.0	173.0	173.0	76.7
MPN10X20L-70 (2-1/2" MPT)	70	9.8	20.3	6.9	2-1/2" MPT	156.0	156.0	193.0	193.0	87.7
MPN10X20L-80 (2-1/2" MPT)	80	9.8	20.3	7.9	2-1/2" MPT	171.0	171.0	210.0	210.0	98.7
MPN10X20L-90 (2-1/2" MPT)	90	9.8	20.3	8.8	2-1/2" MPT	183.0	183.0	224.0	224.0	109.7
MPN10X20L-100 (2-1/2" MPT)	100	9.8	20.3	9.8	2-1/2" MPT	194.0	194.0	236.0	236.0	120.7

- NOTES: 1. Made with 254SMO Stainless Alloy, Nickel Brazed.
 3. Stainless steel MPT fittings and mounting stud bolts.
 4. Design Working Pressure: 300 psig.

Application:

Swimming Pool Applications - See Page 16, 17

MPN Series

Swimming Pool

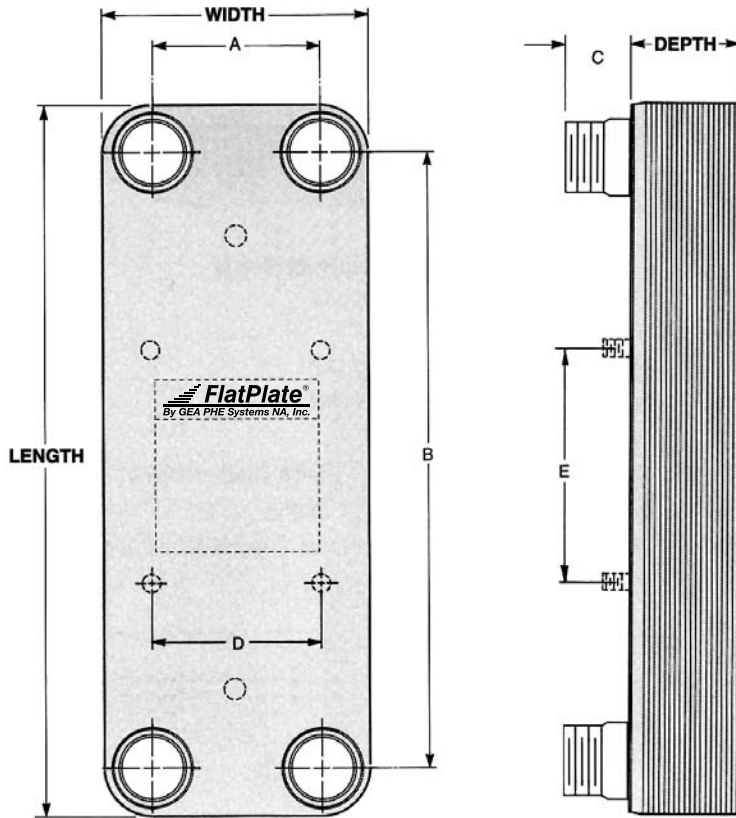



Connections (a)		
# of Plates	Standard	C
	Threaded (MPT)	
5X12" Models		
4 thru 16	1	1.250
20 thru 80	1-1/4	1.375
10X20" Models		
20 and 24	1-1/2	1.500
30 thru 40	2	1.750
50 thru 100	2-1/2	2.000

- (a) Connections the same on both sides
- (b) Heat exchanger may be installed in vertical or horizontal position (except steam application)
- (c) Heat exchanger must be piped in counterflow arrangement
- (d) A water strainer **MUST** be installed in the water inlet circuit (16-20 mesh minimum, 20-40 mesh recommended)
- (e) Water quality should be maintained at a PH of 2.0 or higher
- (f) Designed for chlorinated pool water and process applications
- (g) For swimming pools with electronic chlorinators or salt water, a zinc anode must be installed, attached to the heat exchanger

Stud Bolts:

- 3/8-24 x 7/8" L on all 5 x 12 Models
- 1/2-13 x 1-3/8" L on all 10 x 20L Models

Models	Length	Width	Depth	A	B	C (Min)	C (Max)	D	E	Approximate Weight (lbs)
	(inches)	(inches)	(inches)	(inches)						
MPN5x12	12.2	4.9	0.094 x #plates + 0.36	2.7	9.9	1.13	1.38	2.5	3.5	0.328 x #plates + 3.1
MPN10x20L	20.3	9.8	0.094 x #plates + 0.36	6.5	17.0	1.50	2.00	4.0	5.5	1.1 x #plates + 10.7

  	Specifications	
	Plate Material:	254SMO Stainless Alloy
	Braze Material:	Nickel
	Maximum Working Temperature:	350 F
Minimum Working Temperature:	-320 F	
Maximum Working Pressure:	300 psig	
<ul style="list-style-type: none"> • Optional Floor Mount Brackets and Strainers • Optional Zinc Anodes 		

Radiant Floor Selections

Many radiant floor applications utilize FlatPlate® heat exchangers to reduce overall installed costs of the radiant floor system. This is possible when using cast-iron boilers and radiant tubing (with lower cost, no oxygen barrier), and for applications where isolation of the boiler to radiant floor loops are needed. This simplifies the installation and minimizes cost.

FlatPlate® models also make it possible to interface steam boilers to radiant floor systems, both low pressure and high pressure steam systems (up to 300 psi) using the MPN Series.

Another strong application is using a domestic hot water heater to provide heat to a radiant floor system bathroom radiant floor, or for add-on projects. This is easily accomplished using a FlatPlate® model to isolate the domestic water from the radiant floor loop.

SELECTIONS - Radiant Floor

Connected to Boiler; 180°F Supply

5"x12" Models	Radiant Floor: 80°F Return, 100°F Supply Boiler Return 150°F					Radiant Floor: 100°F Return, 120°F Supply Boiler Return 150°F					Radiant Floor: 120°F Return, 140°F Supply Boiler Return 160°F				
	Capacity	Side-A (Boiler)		Side-B (Radiant)		Capacity	Side-A (Boiler)		Side-B (Radiant)		Capacity	Side-A (Boiler)		Side-B (Radiant)	
	(Btu/hr)	(GPM)	PD (psi)	(GPM)	PD (psi)	(Btu/hr)	(GPM)	PD (psi)	(GPM)	PD (psi)	(Btu/hr)	(GPM)	PD (psi)	(GPM)	PD (psi)
FP5X12L-4 (3/4" MPT)	46,500	3.2	4.6	4.7	2.9	21,500	1.4	1.0	2.1	0.6	12,000	1.2	0.7	1.2	0.2
FP5X12L-6 (3/4" MPT)	100,000	6.8	5.1	10.0	5.6	50,000	3.4	1.4	5.0	1.5	37,500	3.8	1.7	3.8	0.8
FP5X12L-8 (3/4" MPT)	145,000	9.8	4.8	14.5	6.6	85,000	5.7	1.8	8.5	2.4	55,000	5.6	1.8	5.5	1.0
FP5X12L-10 (1" MPT)	185,000	12.6	4.5	18.5	6.9	120,000	8.1	2.0	12.1	3.0	80,000	8.1	2.0	8.1	1.3
FP5X12L-12 (1" MPT)	220,500	15.0	4.1	22.1	6.8	155,000	10.5	2.1	15.6	3.4	105,000	10.7	2.2	10.6	1.6
FP5X12L-14 (1" MPT)	255,000	17.3	3.8	25.6	6.7	200,000	13.6	2.4	20.1	4.2	130,000	13.3	2.3	13.1	1.8
FP5X12L-16 (1" MPT)	289,000	19.7	3.7	29.0	6.7	225,000	15.3	2.3	22.6	4.1	175,000	17.9	3.0	17.7	2.5
FP5X12L-20 (1-1/4" MPT)	360,000	24.5	3.5	36.1	6.7	300,000	20.4	2.5	30.2	4.7	232,000	23.7	3.3	23.5	2.8
FP5X12L-24 (1-1/4" MPT)	435,000	29.6	3.5	43.6	7.0	365,000	24.8	2.5	36.8	4.9	275,000	28.1	3.2	27.8	2.8
FP5X12L-30 (1-1/4" MPT)	525,000	35.8	3.3	52.7	6.9	500,000	34.0	3.1	50.4	6.1	325,000	33.2	2.9	32.9	2.7
FP5X12L-36 (1-1/4" MPT)	610,000	41.5	3.3	61.2	7.0	585,000	39.8	3.0	59.0	6.3	450,000	46.0	4.0	45.6	3.8
FP5X12L-40 (1-1/4" MPT)	650,000	44.3	3.2	65.2	6.8	625,000	42.6	3.0	63.0	6.2	515,000	52.7	4.4	52.2	4.2
FP5X12L-50 (1-1/4" MPT)	765,000	51.1	3.2	75.6	7.0	750,000	51.1	3.2	75.6	7.0	575,000	58.8	4.1	58.3	4.0
FP5X12L-60 (1-1/4" MPT)	810,000	55.2	3.1	81.3	6.9	815,000	55.5	3.2	82.2	6.9	675,000	69.1	4.8	68.4	4.8
FP5X12L-70 (1-1/4" MPT)	840,000	57.2	3.1	84.3	6.9	840,000	57.2	3.1	84.7	6.8	825,000	84.4	6.6	83.6	6.6
FP5X12L-80 (1-1/4" MPT)	915,000	62.3	3.6	91.9	7.9	915,000	62.3	3.6	91.9	7.8	915,000	93.7	7.9	92.7	7.9

- Larger units are available.
- Design Working Pressure: 300 psig.

10"x20" Models	Radiant Floor: 80°F Return, 100°F Supply Boiler Return 150°F					Radiant Floor: 100°F Return, 120°F Supply Boiler Return 150°F					Radiant Floor: 120°F Return, 140°F Supply Boiler Return 160°F				
	Capacity	Side-A (Boiler)		Side-B (Radiant)		Capacity	Side-A (Boiler)		Side-B (Radiant)		Capacity	Side-A (Boiler)		Side-B (Radiant)	
	(Btu/hr)	(GPM)	PD (psi)	(GPM)	PD (psi)	(Btu/hr)	(GPM)	PD (psi)	(GPM)	PD (psi)	(Btu/hr)	(GPM)	PD (psi)	(GPM)	PD (psi)
FP10X20L-20 (1-1/2" MPT)	500,000	34.0	4.9	50.2	9.8	515,000	35.1	5.2	51.9	9.8	500,000	51.2	10.0	50.7	8.9
FP10X20L-24 (1-1/2" MPT)	610,000	41.5	4.9	61.2	10.1	625,000	42.6	5.2	63.0	10.0	610,000	62.4	10.0	61.8	9.2
FP10X20L-30 (2" MPT)	760,000	51.8	4.8	76.3	10.1	770,000	52.5	4.9	77.6	9.8	770,000	78.8	9.9	78.0	9.4
FP10X20L-36 (2" MPT)	910,000	62.0	4.7	91.4	10.1	930,000	63.4	4.9	93.8	10.0	940,000	96.2	10.1	95.3	9.8
FP10X20L-40 (2" MPT)	1,005,000	68.5	4.6	100.9	10.0	1,030,000	70.2	4.8	103.9	10.0	1,040,000	106.5	10.0	105.4	9.8
FP10X20L-50 (2-1/2" MPT)	1,240,000	84.5	4.5	124.5	10.0	1,250,000	85.2	4.6	126.1	9.7	1,300,000	133.1	10.0	131.8	10.0
FP10X20L-60 (2-1/2" MPT)	1,450,000	98.8	4.4	145.6	9.8	1,500,000	102.2	4.6	151.3	9.9	1,500,000	153.6	9.5	152.1	9.6
FP10X20L-70 (2-1/2" MPT)	1,670,000	113.8	4.4	167.7	9.9	1,720,000	117.2	4.6	173.5	10.0	1,750,000	179.2	9.8	177.4	9.9
FP10X20L-80 (2-1/2" MPT)	1,875,000	127.8	4.4	188.3	10.0	1,925,000	131.2	4.6	194.2	10.1	1,950,000	199.7	9.8	197.7	10.0
FP10X20L-90 (2-1/2" MPT)	2,050,000	139.8	4.4	205.9	10.0	2,100,000	143.2	4.6	211.8	10.1	2,140,000	219.1	9.9	216.9	10.1
FP10X20L-100 (2-1/2" MPT)	2,200,000	150.0	4.4	221.0	10.0	2,250,000	153.4	4.6	226.9	10.0	2,250,000	230.4	9.5	228.1	9.7

- Larger units are available.
- Design Working Pressure: 450 psig.

To select a Heat Exchanger for a **Boiler to Radiant Floor** application:

- Step 1 Select the BTUH capacity required.
- Step 2 From the table, select the Heat Exchanger model shown.
Use FP models for water boilers.
Use the closest matching MPN model for steam boilers.
- Step 3 Select your pump(s) based on the minimum recommended flow rates shown on the table.

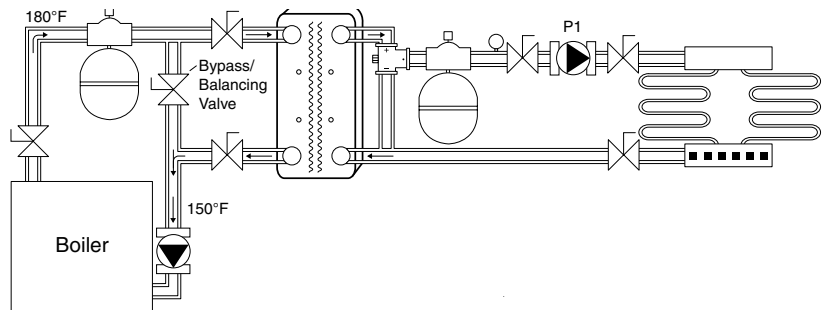

Radiant Floor Selections

Radiant Floor - Hot Water Heater

Hot Water Heater; 140°F Supply, 120° Return

5"x12" Models	Radiant Floor: 80°F Return, 100°F Supply					5"x12" Models	Radiant Floor: 100°F Return, 120°F Supply				
	Capacity (Btu/hr)	Side-A (Boiler) (GPM)	Side-A (Boiler) PD (psi)	Side-B (Radiant) (GPM)	Side-B (Radiant) PD (psi)		Capacity (Btu/hr)	Side-A (Boiler) (GPM)	Side-A (Boiler) PD (psi)	Side-B (Radiant) (GPM)	Side-B (Radiant) PD (psi)
FP5X12L-4 (3/4" MPT)	6,500	0.6	0.2	0.6	0.1	FP5X12-4 (3/4" MPT)	9,500	0.9	2.6	0.9	0.8
FP5X12L-6 (3/4" MPT)	17,500	1.7	0.4	1.7	0.2	FP5X12-6 (3/4" MPT)	18,500	1.8	2.5	1.8	1.2
FP5X12L-8 (3/4" MPT)	30,000	3.0	0.5	3.0	0.4	FP5X12-8 (3/4" MPT)	32,000	3.2	3.2	3.2	1.9
FP5X12L-10 (1" MPT)	47,500	4.8	0.8	4.7	0.6	FP5X12-10 (3/4" MPT)	42,500	4.3	3.2	4.2	2.2
FP5X12L-12 (1" MPT)	61,500	6.2	0.8	6.1	0.7	FP5X12-12 (3/4" MPT)	55,000	5.5	3.4	5.5	2.5
FP5X12L-14 (1" MPT)	75,500	7.6	0.8	7.5	0.7	FP5X12-14 (3/4" MPT)	80,500	8.1	5.0	8.1	3.8
FP5X12L-16 (1" MPT)	90,000	9.1	0.9	9.0	0.7	FP5X12-16 (3/4" MPT)	93,500	9.4	4.9	9.4	3.9
FP5X12L-20 (1-1/4" MPT)	118,000	11.9	0.9	11.8	0.8	FP5X12-20 (1" MPT)	120,000	12.1	4.9	12.1	4.1
FP5X12L-24 (1-1/4" MPT)	179,000	18.1	1.5	17.9	1.3	FP5X12-24 (1" MPT)	146,000	14.8	4.9	14.7	4.3
FP5X12L-30 (1-1/4" MPT)	230,000	23.3	1.6	23.1	1.4	FP5X12-30 (1-1/4" MPT)	186,500	18.9	5.0	18.8	4.5
FP5X12L-36 (1-1/4" MPT)	281,000	28.4	1.7	28.2	1.6	FP5X12-36 (1-1/4" MPT)	225,000	22.8	5.0	22.6	4.6
FP5X12L-40 (1-1/4" MPT)	316,000	32.0	1.8	31.7	1.7	FP5X12-40 (1-1/4" MPT)	250,000	25.3	5.0	25.2	4.7
FP5X12L-50 (1-1/4" MPT)	402,000	40.7	2.1	40.3	2.1	FP5X12-50 (1-1/4" MPT)	305,000	30.9	4.9	30.7	4.6
FP5X12L-60 (1-1/4" MPT)	488,000	49.4	2.6	49.0	2.6	FP5X12-60 (1-1/4" MPT)	359,000	36.4	4.9	36.2	4.7
FP5X12L-70 (1-1/4" MPT)	574,000	58.2	3.3	57.6	3.3	FP5X12-70 (1-1/4" MPT)	410,000	41.5	5.0	41.3	4.9
FP5X12L-80 (1-1/4" MPT)	660,000	66.9	4.2	66.3	4.2	FP5X12-80 (1-1/4" MPT)	450,000	45.6	5.0	45.3	4.9

- NOTES:**
1. Larger units are available.
 2. Design Working Pressure: 300 psig.
 3. All units are standard models.
 4. Made with 316L Stainless Alloy, Copper Brazed.
 5. Stainless steel MPT fittings and mounting stud bolts.

To select a Heat Exchanger for a Hot Water Heater to Radiant Floor application:

Step 1 Select the BTUH capacity required.

Step 2 From the table on Page 8, select the Heat Exchanger model using the second column. This allows a 130°F water heater to provide 120°F supply water to the radiant floor mixing loop.

Use FP models for city water and softened water.

Use MPN models for hard water, well (ground) water, and coastal waters.

For example: For a 40,000 BTUH requirement, select model FP5x12-20 (1" MPT). If well water use the closest matching model, MPN5x12-20 (1" MPT) from page 8.

Step 3 Select your pump(s) based on the minimum recommended flow rates shown on the table.

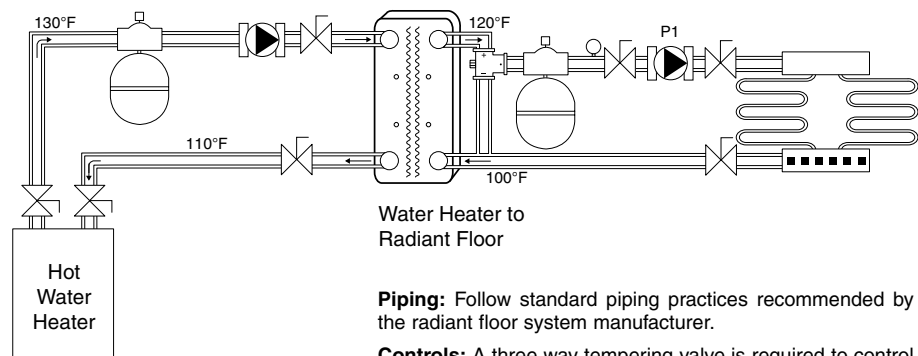

Water Heater to Radiant Floor

Piping: Follow standard piping practices recommended by the radiant floor system manufacturer.

Controls: A three way tempering valve is required to control the radiant floor loop temperature.

Start-up: Adjust the 3 way tempering valve to obtain the desired radiant loop set point. Then, with the radiant floor loop at or near full load, adjust the boiler side bypass/balancing valve to obtain the proper water temperature return to the boiler (ie, 150°F)

Domestic Hot Water Selections

For Domestic Hot Water heating applications, FlatPlate® heat exchangers are ideal and offer a compact, high output capacity. Used in both hot water boiler (FP Series) and steam applications (MPN Series) these heat exchangers offer significant advantages over shell & tube, tank & coil, U-tube bundles, and older technologies. These advantages include 1/5 the size and weight, easier installation and rigging, easy maintenance, faster response and rugged long life use.

FlatPlate® models are excellent for both new construction and replacement applications.

Three types of piping installations are typical.

Recirc to Tank only: In most residential and light commercial applications, a re-circ pump to the hot water tank is typical.

Recirc Loop in Building: For many commercial and industrial applications, a re-circ loop in the building is used, with or without a hot water storage tank.

Instantaneous: In a few installations, instantaneous hot water heating can be used.

To select a heat exchanger for all three of the above Domestic Hot Water heating applications:

Step 1 Select the BTUH capacity required.

Step 2 From the table, select the Heat Exchanger model shown.

Use FP models for water boilers.

Use MPN models for steam boilers.

Step 3 Select your pump(s) based on the minimum recommended flow rates shown on the table. Note: Table 1 is based on 50°F to 140°F standard temperature rise, and the minimum flow rates are 1.5x the corresponding flow for this temperature rise, to maximize BTUH output, and minimize scaling. (If instantaneous hot water heating, same heat exchanger applies, but no minimum flow required.)

Domestic Hot Water

Boiler: 180°F Supply, 150° Return Domestic: 50°F Return, 140° Supply

3"x8" Models	No. of	Capacity	Side-A (Domestic)		Side-B (Boiler)	
	Plates	(Btu/hr)	(GPM)	PD (psi)	(GPM)	PD (psi)
FP3X8-14 (3/4" MPT)	14	18,000	0.4	0.1	1.2	0.2
FP3X8-14 (3/4" MPT)	14	50,000	1.1	0.2	3.4	1.2
FP3X8-14 (3/4" MPT)	14	75,000	1.6	0.5	5.1	2.6
FP3X8-20 (3/4" MPT)	20	100,000	2.2	0.4	6.3	2.5

Boiler: 180°F Supply, 150° Return Domestic: 50°F Return, 140° Supply

5"x12" Models	No. of	Capacity	Side-A (Domestic)		Side-B (Boiler)	
	Plates	(Btu/hr)	(GPM)	PD (psi)	(GPM)	PD (psi)
FP5X12-4 (3/4" MPT)	4	18,000	0.4	0.7	1.2	1.1
FP5X12-4 (3/4" MPT)	4	30,000	0.6	1.4	2.0	2.8
FP5X12-4 (3/4" MPT)	4	40,000	0.8	2.4	2.7	4.8
FP5X12-6 (3/4" MPT)	6	50,000	1.1	1.1	3.4	3.4
FP5X12-6 (3/4" MPT)	6	60,000	1.3	1.4	4.0	4.8
FP5X12-8 (3/4" MPT)	8	70,000	1.5	1.0	4.7	3.7
FP5X12-8 (3/4" MPT)	8	80,000	1.7	1.3	5.4	4.8
FP5X12-10 (3/4" MPT)	10	90,000	2.0	1.0	6.1	3.9
FP5X12-10 (3/4" MPT)	10	100,000	2.2	1.2	6.8	4.8
FP5X12-12 (3/4" MPT)	12	125,000	2.7	1.2	8.5	5.2
FP5X12-14 (3/4" MPT)	14	150,000	3.3	1.2	10.2	5.4
FP5X12-16 (3/4" MPT)	16	175,000	3.9	1.2	11.9	5.7
FP5X12-20 (1" MPT)	20	200,000	4.4	1.0	13.6	4.8
FP5X12-24 (1" MPT)	24	250,000	5.5	1.0	17.0	5.2
FP5X12-24 (1" MPT)	24	300,000	6.7	1.3	20.4	7.3
FP5X12-24 (1" MPT)	24	350,000	7.8	1.6	23.8	9.7
FP5X12-30 (1" MPT)	30	400,000	8.9	1.5	27.2	8.3
FP5X12-36 (1" MPT)	36	450,000	10.0	1.3	30.6	7.5
FP5X12-36 (1" MPT)	36	500,000	11.1	1.4	34.1	9.1
FP5X12-40 (1-1/4" MPT)	40	600,000	13.4	1.6	40.9	10.6
FP5X12-50 (1-1/4" MPT)	50	700,000	15.6	1.5	47.7	9.8
FP5X12-60 (1-1/4" MPT)	60	800,000	17.8	1.5	54.5	9.5
FP5X12-70 (1-1/4" MPT)	70	900,000	20.1	1.5	61.3	9.6
FP5X12-80 (1-1/4" MPT)	80	1,000,000	22.3	1.5	68.2	10.0

Boiler: 180°F Supply, 150° Return Domestic: 50°F Return, 140° Supply

10"x20" Models	No. of	Capacity	Side-A (Domestic)		Side-B (Boiler)	
	Plates	(Btu/hr)	(GPM)	PD (psi)	(GPM)	PD (psi)
FP10X20L-20 (1-1/2" MPT)	20	700,000	15.6	1.5	47.7	7.4
FP10X20L-24 (1-1/2" MPT)	24	900,000	20.1	1.6	61.3	8.4
FP10X20L-30 (2" MPT)	30	1,000,000	22.3	1.3	68.1	6.9
FP10X20L-36 (2" MPT)	36	1,250,000	27.9	1.3	85.2	7.5
FP10X20L-40 (2-1/2" MPT)	40	1,500,000	33.5	1.5	102.2	8.6
FP10X20L-50 (2-1/2" MPT)	50	1,750,000	39.1	1.3	119.3	7.8
FP10X20L-50 (2-1/2" MPT)	50	2,000,000	44.6	1.7	136.3	9.8
FP10X20L-60 (2-1/2" MPT)	60	2,250,000	50.2	1.5	153.4	9.1
FP10X20L-70 (2-1/2" MPT)	70	2,500,000	55.8	1.4	170.4	8.6
FP10X20L-80 (2-1/2" MPT)	80	2,750,000	61.4	1.4	187.5	8.5
FP10X20L-80 (2-1/2" MPT)	80	3,000,000	67.0	1.6	204.5	9.9

Larger models are available.

Domestic Hot Water Selections

Diagram 1-Recirc to Tank

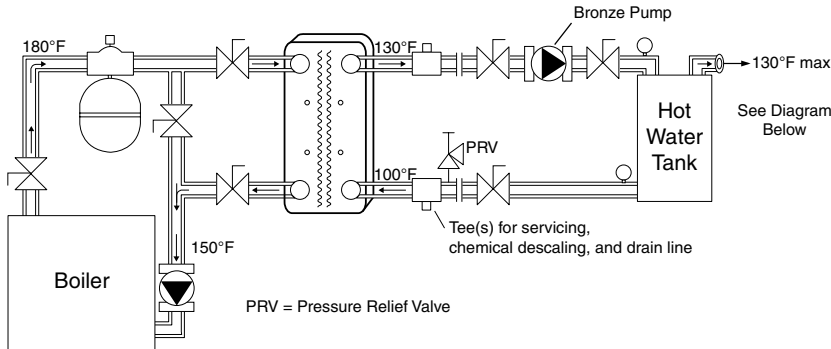

Piping: Tee(s) on the output side of the HX are recommended for convenience in event that future chemical descaling and cleaning is required.

Controls: Typical control of the pumps (Recirc to Tank only) should use an aqua stat in the hot water storage tank to maintain set point temperature (ie, 130°F).

Controls for Re-circ Loops: For re-circulated domestic hot water systems (ie apartments, hospitals, factories and office buildings), a motorized three way mixing valve is *required on the boiler side*, to be modulated based on *leaving water temperature* leaving the heat exchanger into the domestic water loop. The hot water loop pump runs continuously. This maintains the hot water set point for the loop and storage tank. The re-circ pump should flow 100% of the return loop water through the heat exchanger, then to the storage tank (if required, depending upon boiler capacity) at all times to minimize scaling and maximize BTUH output. City water inlet is recommended before the heat exchanger and after the pump, to maximize the heat exchanger capacity.

Diagram 2-Recirc to Building Loop

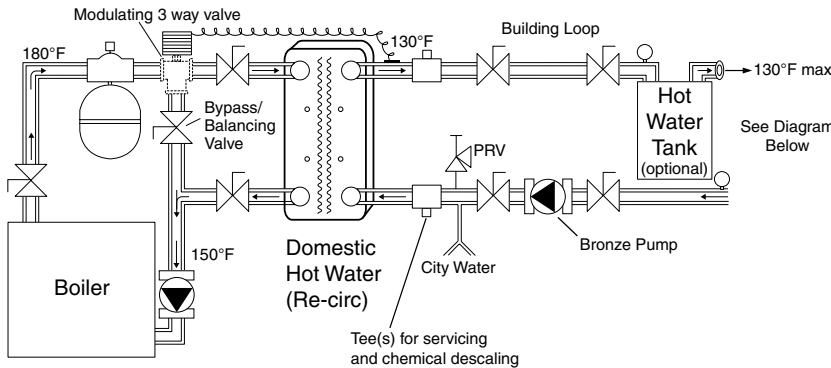

Controls for Instantaneous Water Heating: A three way tempering valve is required, as well as an anti-scaling safety device must be installed. The boiler pump should run continuously.

Controls for Steam Systems: A modulating steam valve and proper steam trapping is required.

Start-up: The bypass/balancing valve should be adjusted at full load to obtain the proper return water temperature to the boiler.

For applications with a recirc domestic hot water loop, the modulating 3 way valve should be adjusted so that it maintains proper domestic water temperature, and does not hunt or overshoot. *Slow to medium response rate is recommended.*

Diagram 3-Instantaneous

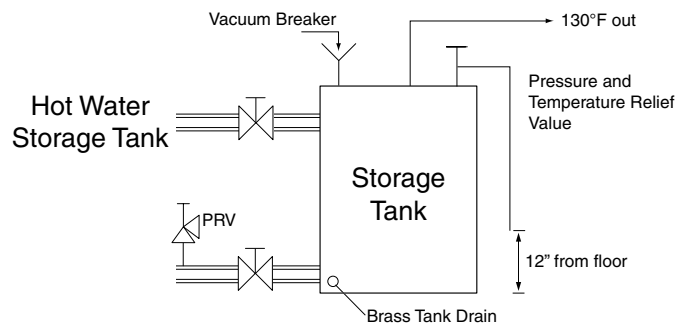
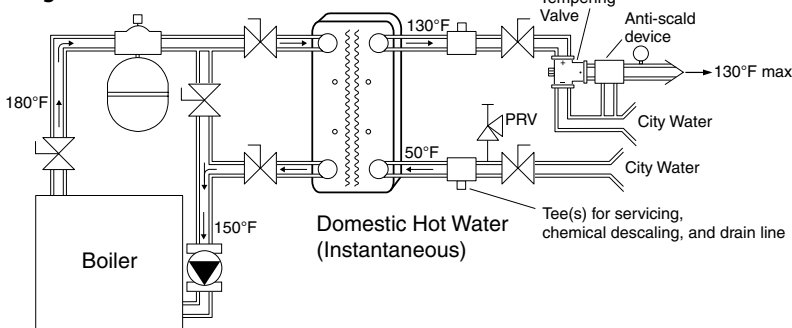

NOTE: Storage tanks over 120 gals. or 200,000 BTU must have ASME Certification.

Domestic Hot Water/Double Wall Selections

The DW Series is a Double Wall, Vented Heat Exchanger designed to meet local and state plumbing codes for double separation of potable water from boiler water, and other non-potable fluids. As a cost effective, full range heat exchanger, the DW Series is a "TRUE" Double Wall Vented design, with double wall plates and double seal fluid ports, both of which have positive leak detection. The DW Series also has "FULL THICKNESS" 316L copper brazed plates for longer life and reliability. Highly compact and easy to install. Ideal for new construction or shell & tube replacement. UL Listed. Optional ASME Code.

Double Wall, Vented

Boiler: 180°F Supply, 150° Return **Domestic:** 50°F Return, 140° Supply

10"x20" Models	No. of Plates	Capacity (Btu/hr)	Side-A (Boiler)		Side-B (Domestic)	
			(GPM)	PD (psi)	(GPM)	PD (psi)
DW10X20-6 (1" MPT)	6	27,500	1.8	5.0	0.6	0.4
DW10X20-10 (1" MPT)	10	55,000	3.7	5.0	1.2	0.8
DW10X20-14 (1" MPT)	14	82,000	5.5	5.0	1.8	0.8
DW10X20-18 (1" MPT)	18	110,000	7.5	5.0	2.4	1.2
DW10X20-22 (1" MPT)	22	135,500	9.2	5.0	3.0	1.2
DW10X20-30 (1-1/4" MPT)	30	177,500	12.1	4.4	3.9	1.2
DW10X20-42 (1-1/4" MPT)	42	240,000	16.3	4.0	5.3	1.2
DW10X20-50 (1-1/2" MPT)	50	283,000	19.2	4.0	6.3	1.2
DW10X20-62 (1-1/2" MPT)	62	347,000	23.6	4.0	7.7	1.2
DW10X20-74 (1-1/2" MPT)	74	411,000	28.0	4.0	9.1	1.2
DW10X20-94 (2" MPT)	94	515,000	35.1	4.0	11.5	1.2
DW10X20-110 (2" MPT)	110	600,000	40.9	4.0	13.4	1.2
DW10X20-134 (2" MPT)	134	730,000	49.7	4.0	16.3	1.2
DW10X20-154 (2" MPT)	154	839,500	57.2	4.0	18.7	1.2
DW10X20-198 (2" MPT)	198	1,075,000	73.3	4.0	24.0	1.2

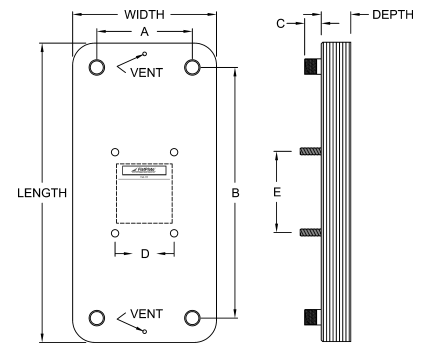

DW 10"x20" Models	No. of Plates	Width (inches)	Length (inches)	Depth (inches)	Connections MPT	GPM @ 5 psig PD		Weight (lbs)
						Side-A & B		
DW10X20-6 (1" MPT)	6	9.8	20.3	1.0	1"	1.8	0.4	18
DW10X20-10 (1" MPT)	10	9.8	20.3	1.4	1"	3.7	0.8	22
DW10X20-14 (1" MPT)	14	9.8	20.3	1.8	1"	5.5	0.8	26
DW10X20-18 (1" MPT)	18	9.8	20.3	2.1	1"	7.5	1.2	31
DW10X20-22 (1" MPT)	22	9.8	20.3	2.5	1"	9.2	1.2	35
DW10X20-30 (1-1/4" MPT)	30	9.8	20.3	3.3	1-1/4"	12.1	1.2	44
DW10X20-42 (1-1/4" MPT)	42	9.8	20.3	4.4	1-1/4"	16.3	1.2	57
DW10X20-50 (1-1/2" MPT)	50	9.8	20.3	5.1	1-1/2"	19.2	1.2	66
DW10X20-62 (1-1/2" MPT)	62	9.8	20.3	6.3	1-1/2"	23.6	1.2	79
DW10X20-74 (1-1/2" MPT)	74	9.8	20.3	7.4	1-1/2"	28.0	1.2	92
DW10X20-94 (2" MPT)	94	9.8	20.3	9.3	2"	35.1	1.2	114
DW10X20-110 (2" MPT)	110	9.8	20.3	10.8	2"	40.9	1.2	132
DW10X20-134 (2" MPT)	134	9.8	20.3	13.0	2"	49.7	1.2	158
DW10X20-154 (2" MPT)	154	9.8	20.3	14.9	2"	57.2	1.2	180
DW10X20-198 (2" MPT)	198	9.8	20.3	19.0	2"	73.3	1.2	229

- NOTES:**
1. Design Working Pressure: 450 psig.
 2. All units are standard models.
 3. Made with 316L Stainless Alloy, Copper Brazed.
 4. Stainless steel MPT fittings and mounting stud bolts.
 5. For ASME versions, put "-UM" after the model number; Example DW10x20-50 (1-1/2" MPT)-UM
 6. For International versions, connections are BSPT; Example DW10x20-50 (1-1/2" BSPT)

Domestic Hot Water/Double Wall Selections

Diagram 1-Recirc to Tank

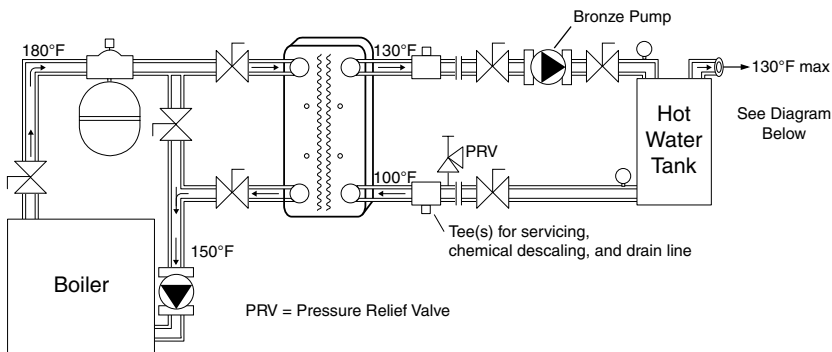

Piping: Tee(s) on the output side of the HX are recommended for convenience in event that future chemical descaling and cleaning is required.

Controls: Typical control of the pumps (Recirc to Tank only) should use an aqua stat in the hot water storage tank to maintain set point temperature (ie, 130°F).

Controls for Re-circ Loops: For re-circulated domestic hot water systems (ie apartments, hospitals, factories and office buildings), a motorized three way mixing valve is *required on the boiler side*, to be modulated based on *leaving water temperature* leaving the heat exchanger into the domestic water loop. The hot water loop pump runs continuously. This maintains the hot water set point for the loop and storage tank. The re-circ pump should flow 100% of the return loop water through the heat exchanger, then to the storage tank (if required, depending upon boiler capacity) at all times to minimize scaling and maximize BTUH output. City water inlet is recommended before the heat exchanger and after the pump, to maximize the heat exchanger capacity.

Controls for Instantaneous Water Heating: A three way tempering valve is required, as well as an anti-scalding safety device must be installed. The boiler pump should run continuously.

Controls for Steam Systems: A modulating steam valve and proper steam trapping is required.

Start-up: The bypass/balancing valve should be adjusted at full load to obtain the proper return water temperature to the boiler.

For applications with a recirc domestic hot water loop, the modulating 3 way valve should be adjusted so that it maintains proper domestic water temperature, and does not hunt or overshoot. *Slow to medium response rate is recommended.*

Diagram 2-Recirc to Building Loop

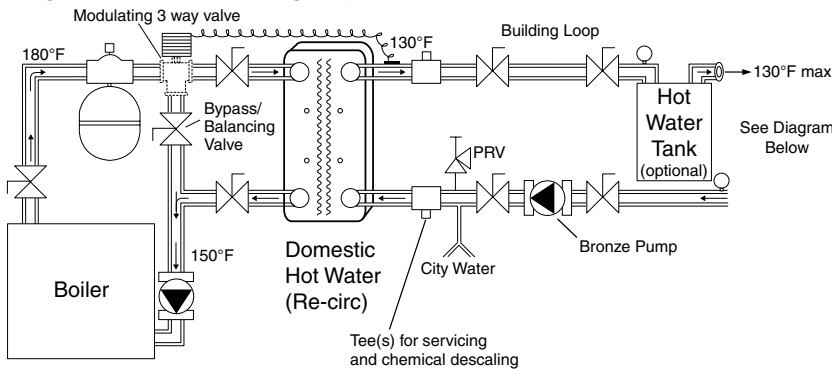
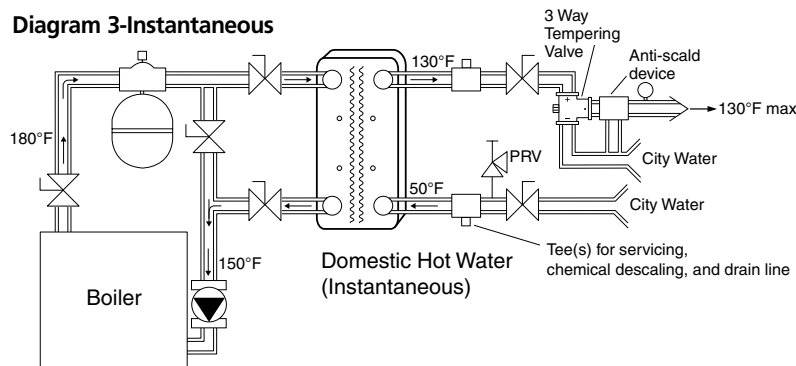

Diagram 3-Instantaneous



Swimming Pools & Spas Selections

Selecting a FlatPlate® Heat Exchanger for Swimming Pool Applications is quick and easy, based on the Total Pool Capacity (gallons), Heat Loss of the pool and the Heat Up Rate desired. MPN Series is designed for Swimming Pool applications where chemically treated water and biological elements are present.

Note: MPN Series Heat Exchangers use a special 254SMO Stainless Alloy and MUST be used in pool environments. Materials such as 316 Stainless steel will corrode and fail due to chlorine, and other chemical and biological elements typical in pool water.

Swimming Pools

To select a Heat Exchanger for Boiler to Pool Water Heating:

Step 1 Select the Heat Up Rate Desired

Pool Use

Periodic Use Only (weekends, holidays)
Extended Use (summer season)

Heat Up Rate

2°F/hour
1°F/hour

Step 2 Determine Pool Capacity

Rectangular Pools

Capacity (gallons) = _____ Length (ft) x _____ Width (ft) x _____ Average Depth (ft) x 7.5 gallons/cu ft

Circular Pools

Capacity (gallons) = _____ Diameter² (ft) x _____ Avg Depth (ft) x .785 x 7.5 gallons/cu ft

Swimming Pools & Spas

1°F/hr Heat Up Rate					2°F/hr Heat Up Rate			
Pool Capacity (Gallons)	Boiler Output Required (Btu/hr)	Boiler Side Minimum (GPM)	Pressure Drop (psig)	GEA FlatPlate Models	Boiler Output Required (Btu/hr)	Boiler Side Minimum (GPM)	Pressure Drop (psig)	GEA FlatPlate Models
1,000	8,345	2	8.7	MPN5X12-4 (1" MPT)	16,690	2	8.7	MPN5X12-4 (1" MPT)
2,000	16,690	2	8.7	MPN5X12-4 (1" MPT)	33,380	2	2.4	MPN5X12-6 (1" MPT)
4,000	33,380	2	2.4	MPN5X12-6 (1" MPT)	66,760	4	4.1	MPN5X12-8 (1" MPT)
6,000	50,070	3	5.1	MPN5X12-6 (1" MPT)	100,140	7	6.9	MPN5X12-10 (1" MPT)
8,000	66,760	4	4.1	MPN5X12-8 (1" MPT)	133,520	9	11.0	MPN5X12-10 (1" MPT)
10,000	83,450	6	5.1	MPN5X12-8 (1" MPT)	166,900	11	5.7	MPN5X12-16 (1" MPT)
12,000	100,140	7	6.9	MPN5X12-10 (1" MPT)	200,280	13	7.8	MPN5X12-16 (1" MPT)
15,000	125,175	8	8.0	MPN5X12-10 (1" MPT)	250,350	17	8.1	MPN5X12-20 (1-1/4" MPT)
20,000	166,900	11	5.7	MPN5X12-16 (1" MPT)	333,800	22	9.2	MPN5X12-24 (1-1/4" MPT)
25,000	208,625	14	9.0	MPN5X12-16 (1" MPT)	417,250	28	9.3	MPN5X12-30 (1-1/4" MPT)
30,000	250,350	17	8.1	MPN5X12-20 (1-1/4" MPT)	500,700	33	7.4	MPN5X12-40 (1-1/4" MPT)
35,000	292,075	18	9.1	MPN5X12-20 (1-1/4" MPT)	584,150	36	8.7	MPN5X12-40 (1-1/4" MPT)
40,000	333,800	19	6.9	MPN5X12-24 (1-1/4" MPT)	667,600	38	6.6	MPN5X12-50 (1-1/4" MPT)
45,000	375,525	21	5.4	MPN5X12-30 (1-1/4" MPT)	751,050	43	8.4	MPN5X12-50 (1-1/4" MPT)
50,000	417,250	24	7.0	MPN5X12-30 (1-1/4" MPT)	834,500	48	7.6	MPN5X12-60 (1-1/4" MPT)
60,000	500,700	29	5.8	MPN5X12-40 (1-1/4" MPT)	1,001,400	57	8.4	MPN5X12-70 (1-1/4" MPT)
70,000	584,150	33	7.5	MPN5X12-40 (1-1/4" MPT)	1,168,300	60	13.6	MPN10X20L-20 (1-1/2" MPT)
80,000	667,600	38	6.6	MPN5X12-50 (1-1/4" MPT)	1,335,200	69	12.1	MPN10X20L-24 (1-1/2" MPT)
90,000	751,050	43	8.3	MPN5X12-50 (1-1/4" MPT)	1,502,100	77	9.8	MPN10X20L-30 (2" MPT)
100,000	834,500	48	7.6	MPN5X12-60 (1-1/4" MPT)	1,669,000	86	11.7	MPN10X20L-30 (2" MPT)
125,000	1,043,125	60	9.2	MPN5X12-70 (1-1/4" MPT)	2,086,250	107	12.5	MPN10X20L-36 (2" MPT)
150,000	1,251,750	54	10.8	MPN10X20L-24 (1-1/2" MPT)	2,503,500	129	9.6	MPN10X20L-50 (2-1/2" MPT)
175,000	1,460,375	75	9.3	MPN10X20L-30 (2" MPT)	2,920,750	150	9.3	MPN10X20L-60 (2-1/2" MPT)
200,000	1,669,000	86	11.7	MPN10X20L-30 (2" MPT)	3,338,000	171	9.2	MPN10X20L-70 (2-1/2" MPT)

- NOTES:**
1. Typical Design Conditions: 180°F Boiler Water and 80°F Pool Water to the Heat Exchanger.
 2. Install a Zinc Anode on the Pool side piping when using an Electronic Chlorinator.
 3. Bypass/Balancing valve on Pool side of Heat Exchanger REQUIRED to allow for full pool pump flow.
 4. Pool side pressure drop for all models ranges from 4.0 psig or higher depending on setting of Bypass/Balance valve.
 5. For 160°F Boiler Water, increase product model size by 1.5 (ie, MPN5x12-16 at 180°F, use MPN5x12-24 at 160°F).
 6. For 200°F Boiler Water and Steam, use the same model size, multiply minimum Boiler GPM by 0.60.
 7. Materials used are; 254SMO Stainless Alloy, Nickel Braze, Stainless Steel MPT fittings and mounting studs.
 8. Design Working Pressure: 300 psig.
 9. Conversion from psig to ft-head. Multiply psig value by 2.31.

Swimming Pools & Spas Selections

Step 3 Select the Heat Exchanger and Boiler Output Required.

From the Selection table, based on the Pool Capacity (gallons) select the appropriate heat exchanger and boiler capacity based on the Heat Up Rate.

For Example: For a 15x30 ft pool, averaging 5.5 ft deep, the pool capacity is 18,563 gallons. Using the Selection table, a 1°F/hr heat up rate, requires 166,900 BTUH and a MPN5x12-16 heat exchanger.

Step 4 Check for Heat Loss to surroundings.

Heat Loss (BTUH) = 12 x ____ Pool Surface Area (sq ft) x ____ (Desired Pool Temp(°F) - ____ Coldest Ambient Temp During Use (°F))

Use this calculation to verify that the Boiler output exceeds the heat loss to surroundings.

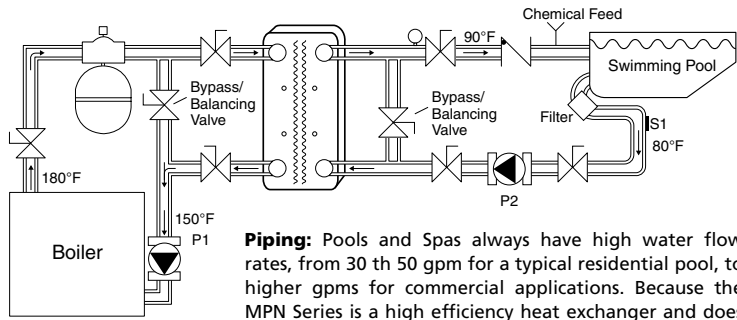

Piping: Pools and Spas always have high water flow rates, from 30 to 50 gpm for a typical residential pool, to higher gpm for commercial applications. Because the MPN Series is a high efficiency heat exchanger and does not require the full pool gpm flow, a BYPASS balancing valve is required to bypass 50% to 80% of the pool water. This bypass/balancing valve should be adjusted and permanently set at start-up.

Chemical feeds MUST be downstream from the heat exchanger, and a check valve should also be installed to prevent back-flow of chemicals into the heat exchanger when the pump is not in operation.

Controls: Temperature control of the pool should be based on a return water temperature stat, controlling (on/off) the boiler and boiler pump. Temperature control of the 90-100°F feed to the pool should be controlled by permanent adjustment of the bypass valve.

Startup: Start up the system, and adjust the pool side bypass valve so that the pool heats up no faster than 2°F/hr, initially. After the pool reaches approximately 78-80°F, and the boiler water is entering at 180°F, adjust the pool side bypass/balancing valve to obtain 90°F to 100°F water to the pool. Then adjust the boiler bypass/balancing valve so that approximately 150°F water is being returned to the boiler.

***NOTE:** The use of Electronic Chlorinators requires the installation of a Zinc Anode in the pool/spa side piping.

Spas

To select a MPN Series Heat Exchanger for a Spa:

Step 1 Determine the Capacity (gallons) of the Spa or Hot Tub. (See Step 2 in Pool calculations)

Step 2 From the Spa selection table, based on the Spa Capacity (gallons) select the appropriate heat exchanger and boiler capacity based on the Heat Up Rate.

Note: A spa is typically operated at 100°F to 105°F, requires a faster heat up rate, and due to aeration, has a higher loss to ambient surroundings. The table below is based on 3F/hr plus ambient losses due to aeration.

2°F/Hr Heat up Rate, plus Aeration			
Spa Capacity Gallons	Boiler Output Required (BTUH)	Boiler Side Minimum GPM	GEA FlatPlate Model
750	31,300	2	MPN5x12-6 (1" MPT)
1,000	41,725	3	MPN5x12-8 (1" MPT)
1,500	62,588	4	MPN5x12-10 (1" MPT)
2,000	83,450	6	MPN5x12-16 (1" MPT)
4,000	166,900	11	MPN5x12-20 (1-1/4" MPT)
6,000	250,350	17	MPN5x12-30 (1-1/4" MPT)
8,000	333,800	22	MPN5x12-40 (1-1/4" MPT)

- NOTES:**
1. Typical Design Conditions: 180°F Boiler Water to Heat Exchanger and 105°F Spa Water.
 2. Bypass/Balancing valve on Spa side of Heat Exchanger REQUIRED to allow for full spa pump flow.
 3. Spa side pressure drop for all models ranges from 4.0 psig or higher depending on setting of Bypass/Balance valve.
 4. For 160°F Boiler Water, increase product model size by 1.5 (ie, MPN5x12-16 at 180°F, use MPN5x12-24 at 160°F).
 5. For 200°F Boiler Water and Steam, use the same model size, multiply minimum Boiler GPM by 0.60.
 6. Materials used are: 254SMO Stainless Alloy, Nickel Braze, Stainless Steel MPT fittings and mounting studs.
 7. Design Working Pressure: 300 psig.
 8. Conversion from psig to ft-head. Multiply psig value by 2.31.

Snow Melt Selections

FlatPlate® heat exchangers are very cost effective in Snow Melt applications and provide high output, fast response and separation of the fluids. Used for Boiler water to Glycol heat transfer, and in some applications, zone isolation, the FP Series provides an easy solution to Snow Melt systems.

Typical Snow Melt systems are Boiler Water to Glycol 10% to 40% (typical) depending upon location and weather conditions, with the heat exchanger providing isolation of the glycol from the boiler water, providing an oxygen barrier to the boiler and protecting other components in the boiler system.

To Select a Heat Exchanger for a Snow Melt application:

- Step 1 Determine the Total BTUH required (from guidance from your Radiant Tube supplier) for the Snow Melt system.
- Step 2 Select the appropriate FP Model from the table, based on the Total BTUH required.

If the Boiler water temperature is 180°F or higher, or steam, use the Table shown. If the Boiler water temperature is less than 180°F Contact your local GEA FlatPlate Representative.

- Step 3 Check the total GPM required. If the GPM requirement of the snow melt system is greater than the GPM listed in the selection table, select a larger model to match the GPM and pressure drop needs, or install a Bypass balancing valve. This will allow full flow and optimum pressure drop for the pump. This applies to the GPM (s) on both Boiler and Glycol sides.

For Example: For a snow melt system requiring a 122,000 BTUH, from the Table, Model FP5x12-14 (3/4" MPT) would be selected. If the GPM requirement is greater than 8.3 use the next larger model to match the pump requirement.

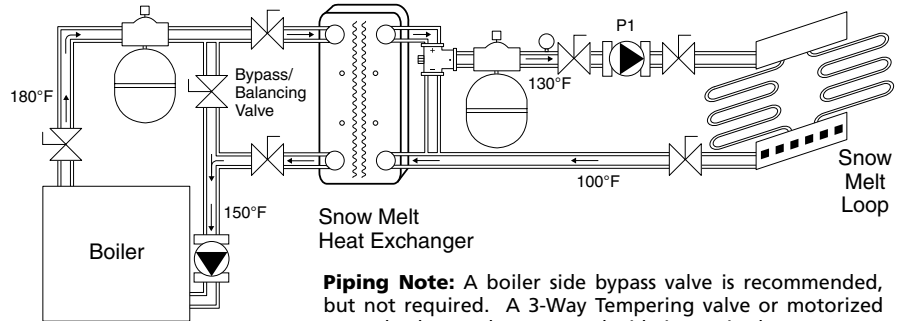

Piping Note: A boiler side bypass valve is recommended, but not required. A 3-Way Tempering valve or motorized control valve on the snow melt side is required.

Controls: A 3-Way Tempering Valve is required to allow for adjustment of the snow melt side, and to limit the temperature of the glycol. For radiant tubing in sand maximum glycol temperature is 140°F. In asphalt and concrete, maximum temperature is typically 150°F. Recommended set point 130°F for the glycol snow melt side.

Start-up: Adjust the 3-Way tempering valve to 130°F or the desired set point.

Snow Melt

Boiler: 180°F Supply, 150° Return **Snow Melt:** 100°F Return, 130° Supply (40% PG)

5"x12" Models	No. of Plates	Capacity (Btu/hr)	Side-A (Boiler)		Side-B (Snow Melt)	
			(GPM)	PD (psi)	(GPM)	PD (psi)
FP5X12-4 (3/4" MPT)	4	20,500	1.3	4.9	1.4	2.5
FP5X12-6 (3/4" MPT)	6	41,000	2.7	4.9	2.9	4.0
FP5X12-8 (3/4" MPT)	8	61,000	4.1	4.9	4.4	4.8
FP5X12-10 (3/4" MPT)	10	82,000	5.5	4.9	5.9	5.5
FP5X12-12 (3/4" MPT)	12	102,000	6.9	4.9	7.3	5.8
FP5X12-14 (3/4" MPT)	14	122,000	8.3	4.9	8.8	6.1
FP5X12-16 (3/4" MPT)	16	144,000	9.8	5.0	10.3	6.4
FP5X12-20 (1" MPT)	20	185,000	12.6	5.0	13.3	6.7
FP5X12-24 (1" MPT)	24	225,000	15.3	5.0	16.2	6.9
FP5X12-30 (1" MPT)	30	282,000	19.2	4.9	20.3	7.0
FP5X12-36 (1-1/4" MPT)	36	337,000	22.9	4.8	24.3	7.0
FP5X12-40 (1-1/4" MPT)	40	372,500	25.4	4.8	26.9	7.0
FP5X12-50 (1-1/4" MPT)	50	457,000	31.1	4.7	33.0	7.0
FP5X12-60 (1-1/4" MPT)	60	600,000	40.9	5.8	43.3	8.5
FP5X12-70 (1-1/4" MPT)	70	675,000	46.0	5.8	48.7	8.5
FP5X12-80 (1-1/4" MPT)	80	800,000	54.5	6.7	57.7	9.7

Boiler: 180°F Supply, 150° Return **Snow Melt:** 100°F Return, 130° Supply (40% PG)

10"x20" Models	No. of Plates	Capacity (Btu/hr)	Side-A (Boiler)		Side-B (Snow Melt)	
			(GPM)	PD (psi)	(GPM)	PD (psi)
FP10X20L-20 (1-1/2" MPT)	20	500,000	34.0	4.9	36.1	6.8
FP10X20L-24 (1-1/2" MPT)	24	650,000	44.3	5.5	46.9	7.9
FP10X20L-30 (2" MPT)	30	850,000	57.9	5.8	61.3	8.5
FP10X20L-36 (2" MPT)	36	1,050,000	71.6	6.0	75.8	9.0
FP10X20L-40 (2" MPT)	40	1,175,000	80.1	6.1	84.8	9.2
FP10X20L-50 (2-1/2" MPT)	50	1,525,000	103.9	6.5	110.1	10.0
FP10X20L-60 (2-1/2" MPT)	60	1,875,000	129.5	7.1	137.2	10.9
FP10X20L-70 (2-1/2" MPT)	70	2,150,000	153.4	7.5	162.4	11.5
FP10X20L-80 (2-1/2" MPT)	80	2,500,000	170.4	7.4	180.5	11.3
FP10X20L-90 (2-1/2" MPT)	90	2,750,000	187.5	7.5	198.6	11.3
FP10X20L-100 (2-1/2" MPT)	100	3,000,000	204.5	7.7	216.6	11.6

- NOTES:**
- Larger models are available. Contact your local FlatPlate® representative
 - For 200° F Boiler Water use the same model size, multiply minimum Boiler GPM by 0.60.

Close Approach Selections

FlatPlate® heat exchangers can be used in applications whereby the “Approach Temperatures” can be 10°F or less, and as low as 2°F. This means that the Heating (or Cooling) Source will Heat (or Cool) the Secondary load side to within a 2°F to 10°F of the Source temperature. This allows for a wide range of applications and versatility for utilizing FlatPlate® heat exchangers. FlatPlate® heat exchangers can be used for many Fluid to Fluid applications where a Heating (or Cooling) Source is used to transfer heat to a Load. Many applications include:

- **Boiler Water to Process**
- **Chilled Water to Process**
- **Glycol to Process Water**
- **Process Water to Process Water**
- **Hot Water Heater to Radiant Floor**
- **Cooling Tower/Free Cooling to Chilled Water loop**
- **Engine Water to Process**
- **High Pressure (300psi) Isolation to Low Pressure (150psi) Equipment**
- **Sea Water to Process (MPN Series)**

Diagram 1-Standard Piping Arrangement 10°F and Higher Approach

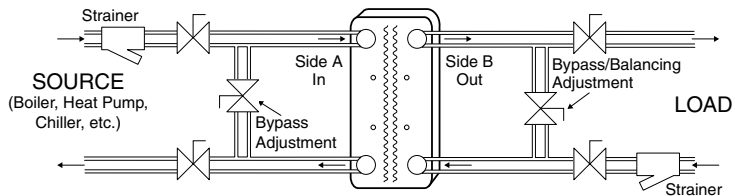
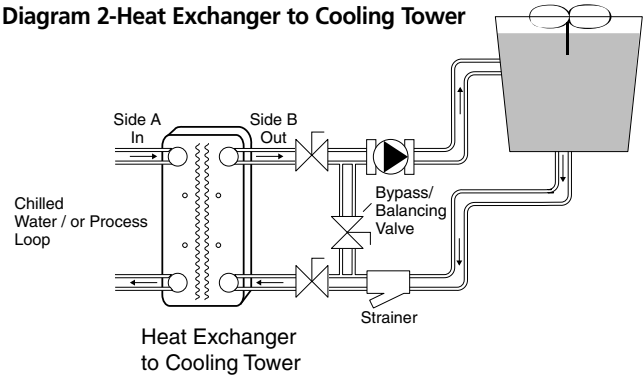

Diagram 2-Heat Exchanger to Cooling Tower



“Approach Temperature” = Side A (Source) Entering Temperature (°F) - Side B (Load) Leaving Temperature (°F)

For Example:

Side A: 95°F in , 85°F out

Side B: 77°F in , 87°F out = 8°F Approach

Temperature Difference (TD) of (Side A or Side B) are defined as:

Entering Temperature - minus Leaving Temperature

For Example:

Side A: 95°F in , 85°F out = 10°F TD for Side A

Side B: 77°F in , 87°F out = 10°F TD for Side B

Optimum “Approach temperature” for a Brazed Plate Heat Exchanger is typically 10°F for cost effective selections, yet 3°F and 4°F Approach temperatures are possible for special applications.

Ideal “Temperature Difference” (TD) is typically 10°F and is widely preferred in many applications.

To select a Close Approach Heat Exchanger, use the Selection Tables.

Step 1 Determine the BTUH Heat transfer required

Step 2 Select the Approach Temperature desired for your application, then use the appropriate Table.

For example: For 100,000 BTUH Boiler water at 180°F, to be used to heat water to 172°F, an 8°F approach, Model FP5x12-36 can be selected from the 8°F Approach table. Note, the tables assume 10°F temperature split on both the boiler (180°F in/170°F out) and 10°F temperature split on the load side (162°F in/172°F out).

Step 3 For fluid temperatures below 80°F, use the Temperature Correction Factor Table. Multiply the Correction Factor times the last two digits of the model number to obtain the appropriate model.

For example: If a FP5x12-50 is selected and one of the fluids is entering at 55°F, multiply the last two digits of the model number by 1.21 (FP5x12-50) to obtain a FP5x12-60 as the appropriate selection.

Diagram 3-High Pressure Isolation

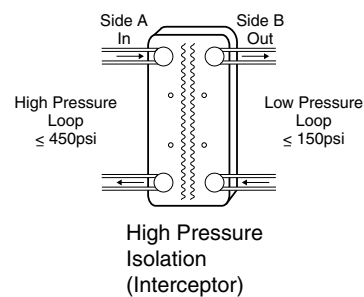

Close Approach Selections

Note: ALL the Tables shown assume a 10°F Split in the IN/OUT temperatures of both Side A and Side B fluids. Identical GPM, both sides. For temperature splits other than a 10°F TD Split or if Glycols are being used, call your local GEA PHE Systems representative for a computer selection.

Close Approach

Approach Temperature = Hot Side Supply Temp. In (Side-A In) minus Cold Side Temp. Out (Side-B Out).

	10°F Approach					8°F Approach					6°F Approach					
	Capacity (Btu/hr)	Side-A (Boiler) (GPM) PD (psi)		Side-B (Radiant) (GPM) PD (psi)		Capacity (Btu/hr)	Side-A (Boiler) (GPM) PD (psi)		Side-B (Radiant) (GPM) PD (psi)		Capacity (Btu/hr)	Side-A (Boiler) (GPM) PD (psi)		Side-B (Radiant) (GPM) PD (psi)		
5"x12" Models																
FP5X12-4 (3/4" MPT)	4,972	1.0	2.6	1.0	0.7	3,977	0.8	1.7	0.8	0.4	1,988	0.4	0.4	0.4	0.1	
FP5X12-6 (3/4" MPT)	9,944	2.0	2.6	2.0	1.2	9,944	2.0	2.6	2.0	1.2	4,972	1.0	0.7	1.0	0.3	
FP5X12-8 (3/4" MPT)	19,888	4.0	4.5	4.0	2.7	17,402	3.5	3.5	3.5	2.0	8,452	1.7	0.9	1.7	0.5	
FP5X12-10 (3/4" MPT)	29,833	6.0	5.7	6.0	3.8	24,363	4.9	3.8	4.9	2.5	11,933	2.4	1.0	2.4	0.6	
FP5X12-12 (3/4" MPT)	39,777	8.0	6.4	8.0	4.6	30,827	6.2	3.9	6.2	2.8	14,916	3.0	1.0	3.0	0.7	
FP5X12-14 (3/4" MPT)	44,749	9.0	5.7	9.0	4.3	38,285	7.7	4.2	7.7	3.2	18,397	3.7	1.0	3.7	1.0	
FP5X12-16 (3/4" MPT)	54,694	11.0	6.2	11.0	4.9	44,749	9.0	4.2	9.0	3.3	22,374	4.5	1.1	4.5	0.9	
FP5X12-20 (3/4" MPT)	74,582	15.0	7.0	15.0	5.8	57,180	11.5	4.2	11.5	3.5	28,838	5.8	1.1	5.8	0.9	
FP5X12-24 (1" MPT)	89,499	18.0	6.8	18.0	5.9	69,610	14.0	4.2	14.0	3.6	36,297	7.3	1.2	7.3	1.0	
FP5X12-30 (1-1/4" MPT)	113,863	23.0	6.9	23.0	6.2	84,527	17.0	3.9	17.0	3.5	46,241	9.3	1.2	9.3	1.1	
FP5X12-36 (1-1/4" MPT)	138,227	28.0	7.1	28.0	6.5	104,416	21.0	4.1	21.0	3.8	57,180	11.5	1.3	11.5	1.2	
FP5X12-40 (1-1/4" MPT)	154,138	31.0	7.2	31.0	6.6	119,332	24.0	4.4	24.0	4.1	64,638	13.0	1.3	13.0	1.2	
FP5X12-50 (1-1/4" MPT)	193,915	39.0	7.5	39.0	7.1	149,165	30.0	4.5	30.0	4.3	79,555	16.0	1.3	16.0	1.3	
FP5X12-60 (1-1/4" MPT)	233,693	47.0	7.9	47.0	7.5	183,971	37.0	5.0	37.0	4.8	99,443	20.0	1.5	20.0	1.4	
FP5X12-70 (1-1/4" MPT)	273,470	55.0	8.4	55.0	8.1	213,804	43.0	5.2	43.0	5.0	114,360	23.0	1.5	23.0	1.5	
FP5X12-80 (1-1/4" MPT)	313,248	63.0	8.9	63.0	8.7	248,609	50.0	5.7	50.0	5.6	129,277	26.0	1.6	26.0	1.6	

	6°F Approach				4°F Approach				3°F Approach						
	Capacity (Btu/hr)	Side-A (Boiler) (GPM) PD (psi)		Side-B (Radiant) (GPM) PD (psi)		Capacity (Btu/hr)	Side-A (Boiler) (GPM) PD (psi)		Side-B (Radiant) (GPM) PD (psi)		Capacity (Btu/hr)	Side-A (Boiler) (GPM) PD (psi)		Side-B (Radiant) (GPM) PD (psi)	
10"x20" Models															
FP10X20-20 (1-1/2" MPT)	139,221	28.0	9.6	28.0	7.9	79,555	16.0	3.3	16.0	2.7	42,263	8.5	1.0	8.5	0.8
FP10X20-24 (1-1/2" MPT)	169,054	34.0	9.5	34.0	8.1	99,443	20.0	3.5	20.0	2.9	52,208	10.5	1.0	10.5	0.8
FP10X20-30 (2" MPT)	218,776	44.0	9.9	44.0	9.9	134,249	27.0	3.9	27.0	3.4	69,610	14.0	1.1	14.0	1.0
FP10X20-36 (2" MPT)	263,526	53.0	9.8	53.0	8.8	164,082	33.0	4.0	33.0	3.6	84,527	17.0	1.1	17.0	1.0
FP10X20-40 (2" MPT)	293,359	59.0	9.7	59.0	8.9	179,000	36.0	3.8	36.0	3.5	94,471	19.0	1.1	19.0	1.0
FP10X20-50 (2-1/2" MPT)	372,914	75.0	10.0	75.0	9.3	228,721	46.0	3.9	46.0	3.7	119,332	24.0	1.1	24.0	1.0
FP10X20-60 (2-1/2" MPT)	442,525	89.0	9.8	89.0	9.3	273,470	55.0	3.9	55.0	3.7	144,193	29.0	1.1	29.0	1.1
FP10X20-70 (2-1/2" MPT)	517,108	104.0	10.0	104.0	9.5	323,192	65.0	4.1	65.0	3.9	174,026	35.0	1.2	35.0	1.2
FP10X20-80 (2-1/2" MPT)	586,719	118.0	10.0	118.0	9.6	372,914	75.0	4.2	75.0	4.0	198,887	40.0	1.2	40.0	1.2
FP10X20-90 (2-1/2" MPT)	651,358	131.0	9.9	131.0	9.6	422,636	85.0	4.3	85.0	4.2	223,748	45.0	1.3	45.0	1.2
FP10X20-100 (2-1/2" MPT)	715,996	144.0	10.0	144.0	9.7	472,358	95.0	4.5	95.0	4.4	248,609	50.0	1.3	50.0	1.3
FP10X20-110 (2-1/2" MPT)	775,663	156.0	9.9	156.0	9.7	522,080	105.0	4.6	105.0	4.5	273,470	55.0	1.3	55.0	1.3
FP10X20-120 (2-1/2" MPT)	835,329	168.0	10.0	168.0	9.8	571,802	115.0	4.8	115.0	4.7	298,331	60.0	1.4	60.0	1.3
FP10X20-130 (2-1/2" MPT)	890,023	179.0	9.9	179.0	9.8	621,524	125.0	5.0	125.0	4.9	323,192	65.0	1.4	65.0	1.4
FP10X20-140 (2-1/2" MPT)	944,717	190.0	10.0	190.0	9.8	671,246	135.0	5.2	135.0	5.1	348,053	70.0	1.4	70.0	1.4
FP10X20-150 (2-1/2" MPT)	994,439	200.0	10.0	200.0	9.8	720,968	145.0	5.4	145.0	5.3	372,914	75.0	1.5	75.0	1.5
FP10X20-160 (2-1/2" MPT)	1,039,189	209.0	9.9	209.0	9.8	770,690	155.0	5.6	155.0	5.5	397,775	80.0	1.5	80.0	1.5
FP10X20-170 (2-1/2" MPT)	1,083,939	218.0	10.0	218.0	9.8	820,412	165.0	5.8	165.0	5.7	422,636	85.0	1.6	85.0	1.6
FP10X20-180 (2-1/2" MPT)	1,128,689	227.0	10.0	227.0	9.9	870,134	175.0	6.0	175.0	6.0	447,497	90.0	1.6	90.0	1.6
FP10X20-190 (2-1/2" MPT)	1,163,494	234.0	9.9	234.0	9.8	919,856	185.0	6.3	185.0	6.2	472,358	95.0	1.7	95.0	1.7
FP10X20-200 (2-1/2" MPT)	1,203,272	242.0	10.0	242.0	9.9	969,578	195.0	6.6	195.0	6.5	497,219	100.0	1.8	100.0	1.8

- Notes:**
- For applications with brackish, pool, spa & Low PH water or steam, substitute Marine 5x12 models. See page 19 for the correct model no. and fluid compatibility.
 - For 2°F approach temperatures, use the 4°F table for Btu/hr and GPM selection to select TWO (2) identical models to be piped in series. Fluid pressure drop will be twice that shown.
 - For 10°F approach temperatures or greater, contact your local FlatPlate representative for exact selection.

Temperature Correction Table	
Fluid Entering Temperature	Model Correction Factor
> 80°F	1.00
> 60°F and < 80°F	1.21
> 32°F and < 60°F	1.42

- Multiply the last 2 digits of the model number to obtain the correct model.
- For Glycol applications, contact your local GEA PHE Systems representative.

Replacement Heat Exchangers

Shell And Tube

It is very easy to use a FlatPlate® Heat Exchanger to replace a Shell/Tube Heat Exchanger. There are two ways to select a FlatPlate® heat exchanger to replace a shell/tube heat exchanger. Both methods provide exact or improved performance selection.

Method A. Heat Transfer Surface Method

This method uses a near exact way of matching the heat transfer surface area of the heat exchanger, which defines the nominal performance of the unit. Because FlatPlate® units perform 20% to 80% better than shell/tube type heat exchangers, on a heat transfer surface basis, a 20% to 80% safety factor embedded in this method. This method works for almost any type of fluid to fluid and steam to fluid heat exchangers.

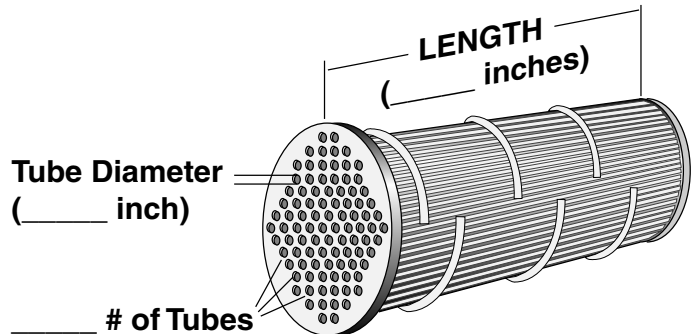

Step 1 Count the number of tubes in the shell/tube heat exchanger
of tubes = _____

Step 2 Measure the external diameter of the tube(s).
OD Diameter of bare tube is: (.25", .375", .5", .625", .75", .875" or _____)
If the tubes have fins or protrusions, call your GEA PHE Systems representative.

Step 3 Measure the length of the tube(s) from end sheet to end sheet. (If U-tube bundle, then use overall length of U-tube bundle.)
Length of tubes = _____ inches

Step 4 Multiply:
#tubes _____ x Diameter of tube _____ (inches) x 3.14 x Tube Length _____ (inches) x .0069 (ft²/in²) x 1.2 Safety factor
= _____ "Sq. Feet" of Heat Transfer Surface

Step 5 Based on the "Sq Feet" Column below, select the corresponding FlatPlate® Model

Hydronic Model	Sq Feet Surface
5x12 models	
FP5x12L-4 (3/4" MPT)	0.8
FP5x12L-6 (3/4" MPT)	1.5
FP5x12L-8 (3/4" MPT)	2.3
FP5x12-10 (3/4" MPT)	3.1
FP5x12-12 (3/4" MPT)	3.8
FP5x12-14 (3/4" MPT)	4.6
FP5x12-16 (3/4" MPT)	5.4
FP5x12-20 (1" MPT)	6.9
FP5x12-24 (1" MPT)	8.4
FP5x12-30 (1" MPT)	10.7
FP5x12-30 (1-1/4" MPT)	10.7
FP5x12-36 (1" MPT)	13.0
FP5x12-40 (1" MPT)	14.6
FP5x12-40 (1-1/4" MPT)	14.6
FP5x12-50 (1" MPT)	18.4
FP5x12-50 (1-1/4" MPT)	18.4
FP5x12-60 (1-1/4" MPT)	22.2
FP5x12-70 (1-1/4" MPT)	26.1
FP5x12-80 (1-1/4" MPT)	29.9

Hydronic Model	Sq Feet Surface
10x20 models	
FP10x20-20 (1-1/2" MPT)	23.6
FP10x20-24 (1-1/2" MPT)	28.9
FP10x20-30 (1-1/2" MPT)	36.8
FP10x20-40 (1-1/2" MPT)	49.9
FP10x20-50 (2" MPT)	63.0
FP10x20-60 (2" MPT)	76.1
FP10x20-70 (2" MPT)	89.3
FP10x20-80 (2" MPT)	102.4
FP10x20-90 (2-1/2" MPT)	115.5
FP10x20-100 (2-1/2" MPT)	128.6
FP10x20-110 (2-1/2" MPT)	141.8
FP10x20-120 (2-1/2" MPT)	154.9
FP10x20-130 (2-1/2" MPT)	168.0
FP10x20-140 (2-1/2" MPT)	181.1
FP10x20-150 (2-1/2" MPT)	194.3
FP10x20-160 (2-1/2" MPT)	207.4
FP10x20-170 (2-1/2" MPT)	220.5
FP10x20-180 (2-1/2" MPT)	233.6
FP10x20-190 (2-1/2" MPT)	246.8
FP10x20-200 (2-1/2" MPT)	259.9

For Steam, CuNi-Cupronickel, and Brass Shell/Tube Replacements, or Swimming Pool water and installations with Questionable water quality, substitute GEA PHE Systems MPN Series for the FP model#.

Replacement Heat Exchangers

Shell And Tube

Step 6 **Installation** - The most important item is that the fluid pressure drop of the new installation, closely matches (+/- 20%) that of the (former) shell/tube installation, so that the pump performance and fluid flow remains the same. Make sure bypass balancing valves are installed on all fluid circuits to the heat exchanger (boiler and secondary side, (excluding steam lines)), then adjust for proper pressure drop across the heat exchanger, which matches the pressure drop across the (former) shell/tube heat exchanger. This ensures a good installation and excellent operation and performance, and customer satisfaction.

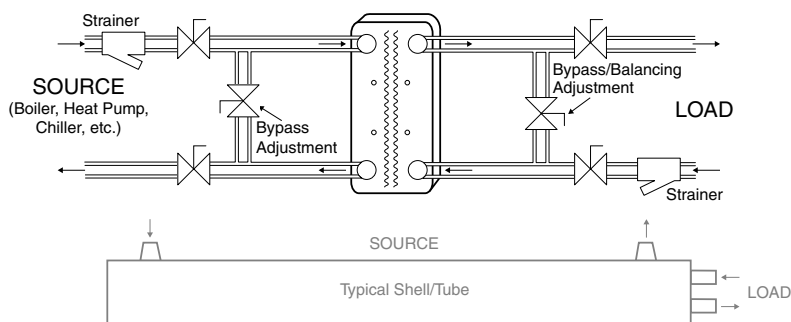

Method B. Design Condition Method

The standard design and selection method of a heat exchanger is based on "Design Conditions". This heat exchanger can then be selected from one of the SELECTION charts in this catalog, or computer selected. The following information is required for a computer selection:

Hot Side A

Fluid _____ (Water, or, %Glycol, or Fluid Type)
 Temperature IN _____ °F (or °C)
 Temperature OUT _____ °F (or °C)
 Flow Rate _____ GPM (or L/min)
 Fouling Factor (.0001 standard)
 Maximum allowable Pressure drop _____ psig

Cold Side B

Fluid _____ (Water, or, %Glycol, or Fluid Type)
 Temperature IN _____ °F (or °C)
 Temperature OUT _____ °F (or °C)
 Flow Rate _____ GPM (or L/min)
 Fouling Factor (.0001 standard)
 Maximum allowable Pressure drop _____ psig

Total Heat Transfer _____ BTUH (or KW)

NOTE: When Replacing a SHELL/TUBE heat exchanger, the FlatPlate® unit will be 1/2 to 1/5th the size and weight of the Shell/tube, for the exact same performance and design conditions. This is due to the compact construction of the FlatPlate® design.

Replacement HX'S Plate



FlatPlate®'s heat exchangers are easy replacement models for several import brands used in a wide range of HVAC/R equipment. Because FlatPlate®'s design is a "Next Generation" design, all FlatPlate® models meet or exceed performance and design pressure ratings of these models. **Use the Selection Chart below,**

Find the FlatPlate® Model which has the:

- 1) Closest model match, and
- 2) Design Applications/performance required, and
- 3) Approximate Unit dimensions

REPLACEMENT HX'S - Selection Table

Fluid to Fluid

<i>GEA FlatPlate Models</i>	Replaces SWEP, Elge Models	Replaces ALFA-LAVAL Models	Replaces Triangle & Weil McLain Models
FP3X8-14 (3/4" MPT)	B5*14	CB12-14 and CB14-14	TTP1-14E and WMBP1-14E
FP3X8-20 (3/4" MPT)	B5*20	CB12-20 and CB14-20	TTP1-20E and WMBP1-20E
FP3X8-30 (3/4" MPT)	B5*30	CB12-30 and CB14-30	TTP1-30E and WMBP1-30E
FP5X12L-4 (3/4" MPT)	B8*10	CB25-6 and CB26-6	TTP1-14E and WMBP1-14E
FP5X12L-6 (3/4" MPT)	B8*10	CB25-8 and CB26-8	TTP1-14E and WMBP1-14E
FP5X12L-8 (3/4" MPT)	B8*16	CB25-12 and CB26-12	TTP1-20E and WMBP1-20E, TTP3-14 and WMBP3-14
FP5X12-10 (3/4" MPT)	B8*20	CB25-14 and CB26-14	TTP4-10 and WMBP4-10
FP5X12-12 (3/4" MPT)	B8*20	CB25-16 and CB26-16	TTP1-30E and WMBP1-30E, TTP3-20 and WMBP3-20
FP5X12-14 (3/4" MPT)	B5*36 and B10*20	CB25-16 and CB26-16	TTP4-14 and WMBP4-14
FP5X12-16 (3/4" MPT)	B8*24	CB25-24 and CB26-24	TTP3-40 and WMBP3-40, TTP4-14 and WMBP4-14
FP5X12-20 (1" MPT)	B8*36 and B10*30	CB25-28 and CB26-28	TTP3-40 and WMBP3-40
FP5X12-24 (1" MPT)	B8*40 and B10*30	CB25-34 and CB26-34	TTP4-24 and WMBP4-24
FP5X12-30 (1" MPT)	B10*40	CB25-44 and CB26-44	TTP4-30 and WMBP4-30
FP5X12-40 (1" MPT)	B10*50	CB25-54 and CB26-54	Not Available
FP5X12-50 (1" MPT)	B10*60	CB25-64 and CB26-64	TTP4-50 and WMBP4-50
FP10X20-20 (1-1/2" MPT)	B45*20 and B50*20	CB75-20 and CB76-20	TTP7-20 and WMBP7-20
FP10X20-24 (1-1/2" MPT)	B45*24 and B50*24	CB75-24 and CB76-24	TTP7-24 and WMBP7-24
FP10X20-30 (1-1/2" MPT)	B45*30 and B50*30	CB75-30 and CB76-30	TTP7-30 and WMBP7-30
FP10X20-40 (1-1/2" MPT)	B45*40 and B50*40	CB75-40 and CB76-40	TTP7-40 and WMBP7-40
FP10X20-50 (2" MPT)	B45*50 and B50*50	CB75-50 and CB76-50	TTP7-50 and WMBP7-50
FP10X20-60 (2" MPT)	B45*60 and B50*60	CB75-60 and CB76-60	TTP7-60 and WMBP7-60
FP10X20-70 (2" MPT)	B45*70 and B50*70	CB75-70 and CB76-70	TTP7-70 and WMBP7-70
FP10X20-80 (2" MPT)	B45*80 and B50*80	CB75-80 and CB76-80	TTP7-80 and WMBP7-80

For Larger Models contact your local GEA PHE Systems representative.

Dimensional Fit

For replacement applications, check the dimensional fit for the following units which maybe slightly larger or smaller than the unit it is replacing.

B5, E5, CB14, TTP1, WMBP1 models are 2.7"W x 8"H, to be replaced with a FlatPlate® 3x8 model, 3.3"W x 7.8"H
 B10, CB25, CB26, TTP4, WMBP4 models are, 4.0"- 4.5"W x 12"H, to be replaced with a FlatPlate® 5x12 model, 4.9"W x 12"H
 B45, B50, TTP7, WMBP7 models are, 9.5"-10"W x 20"H, to be replaced with a FlatPlate® 10x20 model, 9.8"W x 20"H
 CB75, CB76 models are 7.5"W x 24.5"H to be replaced with a FlatPlate® 10x20 model, 9.8"W x 20"H

Pressure Rating

All FlatPlate® FP series models are rated for 450 psig, equal to or greater than the units listed above.

NOTE: TTP1... and WMBP1... models are 150 psig rating.

FlatPlate® models can be substituted at 300 psig rating.

Failure Analysis

If the unit being replaced has been in service for less than 5 years (Plate Heat Exchanger or Shell & Tube), the cause or mode of failure may repeat itself, due to water quality, and other factors.

A failure analysis report can be performed by FlatPlate® for non-FlatPlate® models, for a nominal cost, as part of a replacement heat exchanger order.

Plate & Frame Replacements

Many Plate and Frame heat exchangers (with gaskets) sometimes fail over time and can also be replaced with a FlatPlate® model.

Information needed for replacement includes dimensions of the plates, number of plates, and GPM flow rates.

Please contact your local FlatPlate® representative for assistance.

Accessories

Mounting Brackets

Mounting of any brazed plate unit can be accomplished by 1) using a bar across the face of the unit, or 2) mounting to a steel strut, or 3) by using a mounting bracket. Mounting brackets are designed for easy use, where applicable. BKT and FR models are all stainless steel.

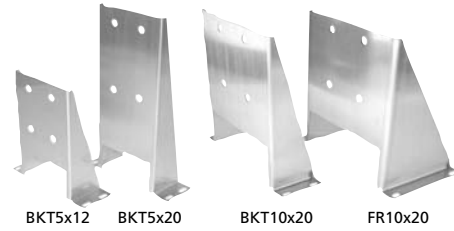

Bracket Model	Type
BKT5x12	Mounting Bracket for 5x12 models
BKT5x20	Mounting Bracket for 5x20 models
BKT10x20	Mounting Bracket for 10x20 models, 10 to 80 plates
FR10x20	Rugged Floor Mounting Frame for 10x20 models, 90 to 200 plates

BKT5x12 & BKT5x20

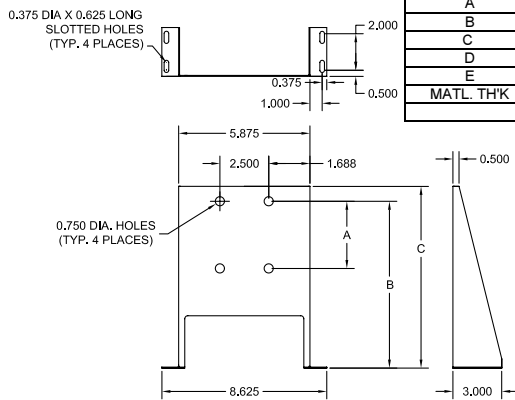

PART #	BKT10X20	FR10X20	BKT5X20	BKT5X12
PLATE COUNT	10-100 PL	110-220 PL	ALL	ALL
A			5.500	3.500
B			13.625	8.625
C			14.875	9.750
D	3.000	7.000		
E	4.000	8.000		
MATL. TH'K	14 GA	10 GA	14 GA	14 GA

MATERIAL: SA-240, 304 SS

BKT & FR10x20

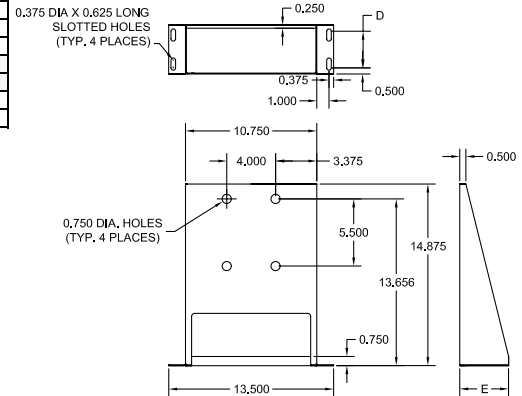

"Y" Strainers



A Water strainer is required for proper protection of the brazed plate fluid side for chillers, condensers, and fluid to fluid units. These strainers are cast bronze, FPT female pipe connection and rated for 400 psi working pressure at 150°F.

Model	Female Pipe connection	Mesh Strainer	GPM @ 1 psi PD	GPM @ 2 psi PD
STR3/4	3/4" FPT	20 mesh	18	26
STR1	1" FPT	20 mesh	28	40
STR1-1/4	1-1/4" FPT	20 mesh	42	60
STR1-1/2	1-1/2" FPT	20 mesh	70	100
STR2	2" FPT	20 mesh	110	140
STR2-1/2	2-1/2" FPT	20 mesh	140	190
STR3	3" FPT	20 mesh	180	260
STR4	4" FPT	20 mesh	300	420

For higher working pressure models or stainless steel versions, please contact the factory.

Zinc Anode



A Zinc Anode is required for all MCN & MPN models used in Swimming Pools with electronic chlorinators and for ALL applications where galvanic corrosion is possible. A Zinc Anode is installed and shipped with all MCN Condensers, and not provided with MPN fluid to fluid models.

Model	Female Pipe Connection
ANODE 3/8	3/8" FPT

Accessories

Insulation Kits



Insulation Kits are available and recommended for FP and all other FlatPlate® models to prevent heat loss and for other applications, such as low temperature glycols. Designed to be applied quickly in 10 minutes or less, the Insulation Kits consist of three sections: a pre-cut front, back and side panel made from 1/2" black Armaflex, with extra strength adhesive backing.

Minimum operating temperature: -40°F. Maximum operating temperature: 220°F

Insulation Kit Model	Use with GEA FlatPlate Model
3x8" Models	FP & FPN
IN-FP3x8-14	FP3x8-14
IN-FP3x8-20	FP3x8-20
IN-FP3x8-30	FP3x8-30
IN-FP3x8-40	FP3x8-40

Insulation Kit Model	Use with GEA FlatPlate Model
5x12" Models	FP, FPN & MPN
IN-FP5x12-8	FP5x12-8
IN-FP5x12-10	FP5x12-10
IN-FP5x12-12	FP5x12-12
IN-FP5x12-16	FP5x12-16
IN-FP5x12-20	FP5x12-20
IN-FP5x12-24	FP5x12-24
IN-FP5x12-30	FP5x12-30
IN-FP5x12-36	FP5x12-36
IN-FP5x12-40	FP5x12-40
IN-FP5x12-50	FP5x12-50
Larger models, use IN520-XX side wall, cut to 32.25" length	

Insulation Kit Model	Use with GEA FlatPlate Model
5x20" Models	FP, FPN
IN-FP5x20-8	FP5x20-8
IN-FP5x20-10	FP5x20-10
IN-FP5x20-12	FP5x20-12
IN-FP5x20-14	FP5x20-14
IN-FP5x20-20	FP5x20-20
IN-FP5x20-24	FP5x20-24
IN-FP5x20-30	FP5x20-30
IN-FP5x20-40	FP5x20-40
IN-FP5x20-50	FP5x20-50
IN-FP5x20-60	FP5x20-60
IN-FP5x20-70	FP5x20-70

Insulation Kit Model	Use with GEA FlatPlate Model
10x20" Models	FP, FPN & MPN
IN-FP10x20-20	FP10x20-20
IN-FP10x20-30	FP10x20-30
IN-FP10x20-40	FP10x20-40
IN-FP10x20-50	FP10x20-50
IN-FP10x20-60	FP10x20-60
IN-FP10x20-70	FP10x20-70
IN-FP10x20-90	FP10x20-90
IN-FP10x20-100	FP10x20-100
IN-FP10x20-130	FP10x20-130
IN-FP10x20-150	FP10x20-150
IN-FP10x20-170	FP10x20-170
IN-FP10x20-190	FP10x20-190

Models not shown, use the next size larger.

- NOTES:**
1. All insulation Kits are three piece die cut, with front, back and side wrap-a-round, 1/2" Armaflex, with peel off pre-glued backing.
 2. Rated for 220°F maximum temperatures.
 3. For <20°F, Two insulation kits recommended. Consult the Factory for correct models.

Quick Reference Calculations

BTU	=	Amount heat required to raise (heat or cool) 1 lb of water 1°F
	=	1054.8 Joules
	=	252 gram-calories
BTU/H	=	Amount of heat over time to raise (heat or cool) 1 lb of water 1°F in ONE hour
BTU/H (water at 68°F)	=	Temp Difference x GPM x 500
BTU/H (30% E. Glycol at 68°F)	=	Temp Difference x GPM x 445
BTU/H (50% E. Glycol at 20°F)	=	Temp Difference x GPM x 375
BTU/H (Most Oils)	=	Temp Difference x GPM x 250
BTU/H (any liquid or gas)	=	$\frac{\text{Temp Difference} \times \text{Specific Heat (BTU/lb}^\circ\text{F)}}{\text{Mass Flow Rate (lbs/hr)}}$
	=	$\frac{\text{Temp Difference} \times \text{Specific Heat (BTU/lb}^\circ\text{F)} \times \text{Density (lb/cu ft)}}{7.4805}$
Celsius (°C)	=	$(^\circ\text{F}-32) \times 5/9$
Conductivity (BTU/hr-ft ² -°F.ft)	=	°C/cm x .05782
1 Cubic Foot	=	7.481 Gallons
	=	1728 Cubic inches
	=	38.32 liters
Density (lb/cu ft)	=	Specific Gravity x 62.344
	=	g/ml x 62.4
Fahrenheit (°F)	=	$(^\circ\text{C} \times 9/5) + 32$
1 Ft. of Head	=	2.307 psi (lbs per sq inch)
1 Foot of Water (68°F)	=	.4335 psi (lb per sq inch)
	=	.2930 watts
1 Horsepower (boiler)	=	34.5 lb of steam at 212°F
	=	33476 BTU/hr
1 Gallon	=	8.346 lbs of water at 68°F
	=	231 cubic inches
	=	3.785 litres
GPM	=	.060308 Liters/sec
	=	3.62 Liters/min
Kelvin (°K) to °F	=	K x 1.8 - 459.7
Kilowatt (KW)	=	3414 BTU/hr
1 Lb of Water	=	.01602 Cu Ft
	=	27.68 Cu Inches
	=	.120 gallons
1 psi (Pound/sq in)	=	2.307 Feet of water
	=	2.036 inches of Mercury
	=	.06802 Bar (atmospheres)
Rankin (°R) to °F	=	°R +459.67
Specific Heat (BTU/lb-°F)	=	cal/g-°C x 1
Tank Capacity Calculation (gallons) (rectangular)	=	Length(ft) x Width(ft) x Depth(ft) x 7.481 (gal/cu ft)
Tank Capacity Calculation (gallons) (cylinder)	=	$\frac{\text{Diameter(ft)}^2 \times 3.14 \times \text{Height(ft)} \times 7.481 \text{ (gal/cu ft)}}{4}$
Tank Heating Total Requirement (BTU total)	=	Tank Temperature Rise x Gallons x 8.346 (plus tank & piping external losses)
Tank Heating Rate (BTU/hr) (Boiler Capacity needed)	=	$\frac{\text{Tank Heating Requirement(BTU)}}{\text{Hrs (hrs desired to bring tank up to temperature)}}$
Tank Heat up Rate (hrs)	=	$\frac{\text{Tank Heating Requirement(BTU)}}{\text{BTU/hr Heat Source Boiler}}$
1 Ton (Refrigeration, chilling)	=	12,000 BTU/hr
1 Ton (Refrigeration. condensing side)	=	15,000 BTU/hr
Viscosity Cp (Centipoise)	=	Centistokes x Density(g/ml)
Viscosity (lb/ft-hr)	=	Cp x 2.42
1 Watt	=	3.413 BTU/hr

Terms and Conditions of Sale

1. GENERAL TERMS.

1.1 Binding Contract. Unless otherwise noted in the Seller's proposal, this proposal shall lapse automatically upon the expiration of a thirty (30) day period after the date of its submission unless it has been previously accepted by Purchaser or revoked in writing by Seller. This proposal does not become a binding contract until Seller confirms the Purchaser's order in writing.

1.2 Plans, Drawing and Illustrations. Proposal pages, catalogue illustrations and preliminary drawings are submitted only to show the general style, arrangement and approximate dimensions of equipment. Seller reserves the right to make such changes of design, construction or arrangement as it deems necessary to achieve the specifications contained herein. Purchaser is to provide the drawings of all foundations, concrete construction and reinforcement and required housings, based upon Seller's equipment drawings.

1.3 Proprietary and Confidential Information. This proposal and all drawings, notebooks, operating data, specifications, and other information, data and material (whether orally disclosed, printed, handwritten, typed, numerically or computer generated, computer stored, or otherwise) furnished to Purchaser by either Seller or any of its subcontractors or suppliers shall remain the proprietary and confidential property of Seller or the subcontractor or supplier, respectively, and shall be used by Purchaser only with respect to the work covered by the contract and shall not be used by Purchaser in connection with any other project. --Such proprietary and confidential information and data shall not be shown or otherwise made available to any third party at any time without Seller's prior written consent. Neither Purchaser itself shall, nor shall Purchaser permit any third party to, reverse engineer, measure or otherwise technically examine or test Seller's equipment without Seller's prior written consent. Any such proprietary and confidential information which Purchaser determines must be disclosed to its employees, shall only be disclosed to its employees on a need-to-know basis for the operation, maintenance, and repair of the equipment provided under the contract. Intellectual property or patent rights which may be obtained on the basis of the information given or made available to Purchaser under the contract or with respect to Seller's equipment shall remain the exclusive property of Seller or its subcontractor and/or supplier, respectively.

2. SAFETY REQUIREMENTS OF PURCHASER.

Purchaser shall use, and shall train and require its employees to use and shall cause any end user to use, all safety devices, guards, and proper safe operating and maintenance procedures as prescribed by all applicable laws, rules, regulations, codes and standards and as set forth in operating and maintenance manuals and instruction sheets furnished by Seller. Purchaser shall not, and shall cause any end user not to, remove or modify any safety device, guard or warning sign. If the Purchaser fails to strictly observe any of the obligations set forth in the preceding two sentences with regard to any of Seller's equipment, Purchaser agrees to defend Seller against and indemnify and save Seller harmless from, any claim, liability or obligation (including the costs and attorneys' fees of any suit or claims related thereto) incurred by Seller as a result of persons being injured or property being damaged directly or indirectly in connection with the operation of such equipment as a result of such failure. Purchaser also agrees to indemnify and save Seller harmless from, any claim, liability or obligation incurred by Seller as a result of persons being injured or property being damaged due to Purchaser's use of Seller equipment for materials or products not specified in the contract or use of non-original replacement parts not specifically authorized in writing by Seller or due to changes in the Seller equipment made by Purchaser without Seller's specific written authorization.

3. CHANGE REQUESTS.

The Purchaser has the right to ask for variation in the scope of supply. To this end the Purchaser shall inform the Seller in due time in writing about any details of such demand ("Change Request"). The Seller shall, within 14 working days from the reception of the Change Request, make an offer in writing to the Purchaser regarding the performance of the demanded variations (additional purchase price, modified delivery periods etc.). If a longer period of time from 14 days is required to determine the delay or cost increase necessitated by the change, then the Seller must advise the Purchaser within such 14 days and proceed diligently thereafter to determine the additional costs and time required. In case the Purchaser accepts said offer the Seller shall be obliged to perform the agreed modifications subject to changes being made to the purchase order or contract to reflect the Seller's response to the Change Request. Notwithstanding the foregoing, the Seller shall not be required to accept any change which the Seller believes in good faith is technically impossible or unsafe, then the change will not be made.

4. COMPLIANCE WITH LAWS.

The equipment or work purchased from Seller shall comply with all applicable laws, rules, regulations, codes and standards of all federal, state, local and municipal governmental agencies having applicable regulatory jurisdiction, as such laws, rules, regulations, codes and standards are in effect on the date of the contract, provided that: (i) the Purchaser will include in its specifications or will bring to the attention of Seller in writing any state, local or municipal laws, rules, regulations, codes or standards which are different from those imposed by the federal governmental agencies and authorities; (ii) if any such federal, state, local or municipal laws, rules, regulations, codes or standards are changed, or if new laws, regulations, codes or standards or interpretations thereof are enacted or adopted subsequent to the date of the contract, which require a change in Seller's equipment or work, an equitable adjustment shall be made to the contract price, delivery schedule and payment terms; and (iii) Seller does not guarantee any compliance with, nor will Seller incur any liability for failure of the equipment or work to comply with, any federal, state or local pollution control, effluent or utility control laws, rules, regulations, codes or standards.

5. PRICE AND PAYMENT.

5.1 The purchase price shall be paid in accordance with the Seller's proposal. Any right to retain due payments or to set-off counterclaims shall be excluded unless any such claim or counterclaim of the Purchaser is undisputed or has been determined by a final judgment of the competent court or arbitration court.

5.2 Whatever the means of payment used, payment shall not be deemed to have been effected before the Supplier's account has been fully and irrevocably credited.

5.3 If the Purchaser fails to pay by the stipulated date, the Seller shall be entitled to interest from the day on which payment was due. The rate of interest shall be one and one-half percent (1½%) per month until the payment is made in full. Additionally, if Seller is required to expend costs and expenses in collecting any payments, Purchaser shall reimburse the Seller for such costs of collection (including reasonable attorneys fees).

In case of late payment the Seller may suspend his performance of the contract until it receives payment. If the Purchaser has not paid the amount due within three months the Seller shall be entitled to terminate the contract by notice in writing to the Purchaser and to claim compensation for the losses and damages it has incurred.

6. TRANSPORTATION; INSURANCE; RISK OF LOSS.

6.1 Transportation; Shipping.

6.1.1 Where transportation costs are prepaid, equipment will be shipped to an unloading point designated by the Purchaser. Unloading, haulage

from the designated unloading point and further necessary handling shall be at the Purchaser's risk and expense, independent of any installation services that may be requested by the Purchaser.

6.1.2 Shipping instructions are to be supplied by the Purchaser within 30 days after release of the purchase order by Purchaser. In the event Purchaser fails to supply shipping instructions, it shall be invoiced and Seller at its option may place the equipment in Seller's or any public or private storage facilities at the Purchaser's risk and expense.

6.2 Insurance. Purchaser accepts full responsibility for the safeguarding of all equipment delivered to the Purchaser until it is paid for in full. Until the contract price is paid in full, Purchaser shall provide and maintain insurance to the total value of the equipment delivered hereunder against all risks of fire and explosion in the names of Purchaser and Seller, as their respective interests may appear, and shall also provide and maintain such insurance to the above value against flood, earthquake, windstorm, cyclone, tornado, hurricanes, riot and strike and civil commotion.

6.3 Title; Right of Possession; Security for Payment. The parties mutually agree that the equipment specified herein shall at all times remain personal property regardless of the degree of its annexation to the real property and that the equipment shall not, by reason of any annexation to real property become a part thereof or otherwise a fixture. Title and right of possession of such equipment shall remain in Seller at all times. Title shall pass to Purchaser in accordance with the delivery terms for the equipment. Without waiving any rights to elect to proceed under applicable lien laws, Seller reserves a security interest in the equipment and parts furnished by it. By accepting delivery of the equipment or parts, Purchaser grants to Seller a security interest in such equipment and parts to secure the full and prompt payment for such equipment and parts until the agreed price (including any notes therefor) for such equipment and parts has been fully paid in cash. In the event of default in payment, Seller shall have all rights of repossession and other rights available to a secured party under the laws applicable thereto. Any equipment or parts may be separated from real estate for purpose of repossession by Seller or by its agent without liability for such removal if the Purchaser is in default in payment. Seller is authorized to execute, deliver and file with the appropriate filing office or offices any assignments, financing statements and other documents which Seller may require to evidence or perfect such security interest in accordance with applicable laws.

7. SELLER'S REMEDIES.

7.1 In the event of the insolvency of the Purchaser, Seller reserves the right to cancel the sale as well as the right to stop delivery of the goods and to resell same. Such a right shall not restrict or otherwise impair Seller's remedies for damages in the event of Purchaser's breach.

7.2 Should Purchaser fail to comply with the terms and conditions set forth herein, or if any writ or execution be levied on any of Purchaser's property, or a receiver be appointed, or if a petition in bankruptcy be filed by or against Purchaser, Seller may, upon election, demand the entire purchase price stated herein or may without notice or demand by process of law or otherwise, take possession of all or any of the equipment, wherever located, and retain all monies theretofore paid as compensation for the reasonable use of such equipment. If a contract arising from this proposal is breached and is placed in the hands of an attorney for collection of any balance due or enforcement of any other of Seller's remedies, Purchaser agrees to pay all reasonable attorneys' fees and all other expenses, including therein paid or incurred by Seller. Purchaser hereby waives any and all claims, damages and demands against Seller arising out of the repossession, retention and repair as aforesaid. All rights and remedies contained herein are cumulative and not alternative.

7.3 Seller reserves all other rights and remedies available to it in the event of Purchaser's breach.

8. ASSIGNMENT.

The Purchaser shall not have the right to assign the agreement without the written consent of Seller.

9. INCREASE IN COST OR PRICE.

Unless otherwise noted in Seller's proposal, all prices quoted are subject to surcharges in accordance with the provisions posted on a monthly basis on the Seller's Internet site. If shipment should be delayed by Purchaser beyond sixty (60) days or as specified in the Seller's proposal, the price may be increased to the price in effect at the time the equipment is shipped.

10. SELLER'S LIABILITY; FORCE MAJEURE.

10.1 Seller shall not be liable for loss or damage of any kind resulting from: (i) Purchaser failing to supply any necessary technical data, as required; (ii) Purchaser failing to supply the apparatus, materials and services required; (iii) any changes in designs or specifications made subsequent to acceptance of this proposal; (iv) failure of suppliers to furnish purchased material or auxiliary equipment within scheduled dates provided that the purchased material or auxiliary equipment was properly ordered and appropriately expedited; (v) by any other reason beyond its control; or (vi) any delay caused by late payments by Purchaser.

10.2 Seller shall attempt to overcome but shall not be liable for any loss or damage from delay in delivery of any equipment or completion of any work as a result of causes of any kind beyond the reasonable control of Seller, such as, but not limited to, strikes or other labor difficulties, war, riots, changes in laws and regulations and other acts of governmental authorities, inclement weather, fire, flood or unavoidable casualties, or any delays in transportation of materials, or inability to obtain timely delivery of materials from suppliers where such transportation or delivery has been properly procured and appropriately expedited. In the event of any such delay, Seller will notify the Purchaser within a reasonable time after Seller becomes aware of such cause of delay and it is agreed that the time for delivery or completion shall be extended for a period of time at least equal to the time lost by reason of the delay.

11. MATERIAL AND WORKMANSHIP WARRANTY.

Seller warrants to the Purchaser that the equipment purchased from Seller is free from defects in material and workmanship for a period of twelve (12) months from the date of Purchaser's initial operation using the equipment but not more than eighteen (18) months from the date of delivery of the equipment to the Purchaser. If the equipment is installed in accordance with Seller's specifications and instructions and is used and maintained normally and properly in accordance with Seller's instructions as to maintenance and operation, as set forth in written operation and maintenance manuals and instruction sheets furnished by Seller: (i) the equipment has not been changed without the prior written approval of Seller; (ii) Purchaser gives prompt written notice to Seller before the end of the warranty period specifying all alleged defects in the equipment purchased; and (iv) Purchaser preserves and turns over to Seller and permits reasonable inspection by Seller of all allegedly defective equipment, parts or items and access to the equipment to observe its startup, operation and maintenance.

This warranty shall not cover (i) any equipment furnished by Purchaser or any third party (other than a subcontractor of Seller), (ii) any defects arising from corrosion, abrasion, use of unsuitable lubricants, freezing or other operation outside of prescribed temperature ranges, or negligent attendance or faulty operation, (iii) ordinary wear and tear, or (iv) any defects caused by errors on the part of the Purchaser in not providing a suitable place in which the equipment is to be located, adequate foundation works, or adequate protection against influences within or outside the place of the equipment is to be located which may affect the equipment or its operation. Notwithstanding the warranty set forth above, Seller shall not warrant any equipment, where the vendor of such equipment (other than Seller) is specified by Purchaser, for a period longer than warranted by the vendor.

UNLESS OTHERWISE EXPRESSLY STATED IN ANY DOCUMENT ATTACHED TO THESE TERMS AND CONDITIONS, THIS WARRANTY OF MATERIAL AND WORKMANSHIP IS THE ONLY WARRANTY MADE BY SELLER AND IS IN LIEU OF ALL OTHER WARRANTIES, EXPRESS OR IMPLIED, AND SELLER DISCLAIMS ON BEHALF OF ITSELF, ITS SUBCONTRACTORS AND SUPPLIERS ANY AND ALL IMPLIED WARRANTIES, INCLUDING, WITHOUT LIMITATION, WARRANTIES OF MERCHANTABILITY, FITNESS FOR A SPECIFIC PURPOSE (OTHER THAN THE PURPOSE STATED IN THE PURCHASER'S SPECIFICATIONS SET FORTH IN THE CONTRACT), SUITABILITY OR PERFORMANCE. No other promise or affirmation of fact (including but not limited to statements regarding capacity or performance of the equipment) shall constitute a warranty of Seller or give rise to any liability or obligation on the part of Seller.

Seller's obligation under this warranty and any other warranty or guarantee which is part of the contract is strictly and exclusively limited to furnishing repairs or replacements for equipment or parts determined to be defective on inspection by an authorized representative of Seller. Notwithstanding this exclusive remedy, if it is ultimately determined that the remedy fails in its essential purpose, then any action which may be brought against Seller subject to the terms of the contract will be limited to 100% of the contract price for the purchased equipment for which the exclusive remedy has so failed. Seller assumes no responsibility and shall have no liability for any repairs or replacements by Purchaser without Seller's prior written authorization. If Seller did not repair or replace the equipment, Seller shall have no liability for the costs of removing or segregating any defective equipment so that the repairs or replacements can be made.

12. DAMAGES.

NOTWITHSTANDING ANY OTHER PROVISION OF THE CONTRACT TO THE CONTRARY:

(A) SELLER'S AND ITS SUBCONTRACTORS' AND SUBSUPPLIERS' AND OTHER RESPONSIBILITY LIABILITY WHETHER ARISING OUT OF CONTRACT OR TORT OR ANY OTHER LEGAL CONTEXT OR THEORY, INCLUDING NEGLIGENCE AND STRICT LIABILITY, UNDER THE CONTRACT, INCLUDING, BUT NOT LIMITED TO, ALL CLAIMS FOR BREACH OF ANY WARRANTY OR GUARANTEE, FAILURE OF PERFORMANCE OR DELAY IN PERFORMANCE BY SELLER OR PERFORMANCE BY SELLER OR NON-PERFORMANCE OF THE PURCHASED EQUIPMENT SHALL NOT EXCEED THE CONTRACT PRICE FOR THE PURCHASED EQUIPMENT; PROVIDED, HOWEVER, THAT THIS LIMITATION WILL NOT APPLY TO ANY LIABILITY OF SELLER FOR DIRECT DAMAGES CLAIMED BY PURCHASER FOR PHYSICAL DAMAGE TO PURCHASER'S PROPERTY (OTHER THAN EQUIPMENT PROVIDED BY SELLER) OR FOR DIRECT DAMAGES CLAIMED BY THIRD PARTIES FOR SUCH THIRD PARTIES' PERSONAL INJURY OR PHYSICAL PROPERTY DAMAGE (FOR WHICH PURCHASER IS LIABLE) TO THE EXTENT CAUSED BY THE NEGLIGENT ACTS OR OMISSIONS OR WILLFUL MISCONDUCT OF THE SELLER, FOR ALL OF WHICH MATTERS SELLER SHALL BE LIABLE UP TO AN AMOUNT OF \$1,000,000 IN THE AGGREGATE, AND

(B) IN NO EVENT SHALL SELLER, ITS SUBCONTRACTORS OR SUBSUPPLIERS BE LIABLE IN CONTRACT OR IN TORT OR UNDER ANY OTHER LEGAL CONTEXT OR THEORY, INCLUDING NEGLIGENCE AND STRICT LIABILITY, FOR ANY SPECIAL, PUNITIVE, INDIRECT, INCIDENTAL OR CONSEQUENTIAL DAMAGES OF ANY KIND OR CHARACTER, INCLUDING, BUT NOT LIMITED TO, LOSS OF USE OF PRODUCTIVE FACILITIES OR EQUIPMENT, COSTS OF PRODUCT RECALL, PLANT DOWNTIME, DAMAGE TO OR LOSS OF PRODUCT, CHEMICALS, CATALYSTS, FEEDSTOCK OR OTHER RAW MATERIALS, LOSS OF REVENUES OR PROFITS OR LOSS UNDER PURCHASES OR CONTRACTS MADE IN RELIANCE ON THE PERFORMANCE OR NON-PERFORMANCE OF THE PURCHASED EQUIPMENT, WHETHER SUFFERED BY PURCHASER OR ANY THIRD PARTY, OR FOR ANY LOSS OR DAMAGE ARISING OUT OF THE SOLE OR CONTRIBUTORY NEGLIGENCE OF THE PURCHASER, ITS EMPLOYEES OR AGENTS OR ANY THIRD PARTY.

TO THE EXTENT THAT SELLER OR THE PURCHASER MAKES ANY CLAIM UNDER ANY FRAUD OR TORT THEORY, THE PROVISIONS INCLUDING CIRCUMVENTING THE LIMITATIONS AND DISCLAIMERS SET FORTH ABOVE AND IS UNSUCCESSFUL IN PREVAILING ON THOSE CLAIMS, IT HEREBY AGREES TO REIMBURSE AND INDEMNIFY THE OTHER PARTY FOR ALL ATTORNEYS' FEES AND EXPENSES AND COSTS INCURRED BY THE OTHER PARTY IN DEFENDING SUCH CLAIM.

13. ALTERATION - MODIFICATION.

No waiver, alteration or modification of the foregoing terms and conditions, except as noted in the text of this proposal shall be valid unless made in writing and signed by an authorized representative of Seller.

14. PATENTS.

Seller shall hold Purchaser harmless against any claim that Seller's equipment infringes United States apparatus patents, but Seller makes no representation or warranty, and Seller shall have no responsibility for any infringement or unfair competition resulting from the use of Seller's equipment with the Purchaser's process, or in combination with other equipment not supplied by Seller.

15. PRODUCT SELECTION AND USE.

The Purchaser shall be responsible for accurate design and operating conditions used in the selection and use of the Seller's products. The Purchaser's selection and use of Seller's products from published literature shall be at the Purchaser's risk as to appropriate application, design conditions and performance criteria use.

16. STANDARDS AND TOLERANCES.

All product dimensions and published information is subject to change without notice. All of Seller's products furnished to the Purchaser shall also be subject to tolerances and variations consistent with usages of the trade concerning dimensions, composition and mechanical properties and normal variations in performance characteristics and quality.

17. INTEGRATION CLAUSE.

By acceptance of this proposal, the Purchaser acknowledges (1) that it has not relied on any previous written, oral or implied representation, inducement or understanding of any kind or nature, (2) that Seller's proposal, including these General Terms and Conditions of Sale and any drawings incorporated in the proposal by reference, embodies the entire agreement between the Purchaser and Seller and supersedes all prior agreements and understandings, both written and oral, among the parties with respect to the subject matter hereof, (3) that the contract entered into by acceptance of Seller's proposal by the Purchaser may not be modified or terminated except in writing signed by a duly authorized representative of Seller making specific reference to this contract, and (4) the Purchaser may not assign the contract without the prior written consent of Seller.

18. DISPUTE RESOLUTION; GOVERNING LAW

Any determination, agreement or performance which is disputed or cannot be made, resolved or agreed within fourteen (14) days of the date requested by either Purchaser or Seller or such longer period for resolution as may be mutually agreed shall be submitted for resolution by the chief executive officers of the Purchaser and the Seller. It shall be a condition precedent to any subsequent proceeding that the dispute shall be submitted for resolution by such chief executive officers, but if those officers shall not reach a resolution within twenty-one (21) days of submittal of the matter, the matter shall be finally settled by arbitration under the Rules of the American Arbitration Association by one or more arbitrators appointed in accordance with such Rules. The place of arbitration will be Philadelphia, Pennsylvania. The contract between the Seller and the Purchaser and their respective performances shall be construed under and governed by the laws of Pennsylvania.

GEA PHE Systems
Competence in Heat Transfer

With emphasis on the highest quality standards and constant innovations, GEA PHE Systems continues to expand its market position: Within the GEA Process Equipment Division, GEA Ecoflex together with GEA Ecobraze, GEA WTT, GEA PHE Systems NA, GEA VIEX and GEA EcoServe forms GEA PHE Systems, the Center of Competence and Service Center for gasketed, brazed and fully welded plate heat exchangers of GEA Group:

- HVAC
- refrigeration
- sugar
- chemical
- paper
- food
- life science
- marine
- power
- renewable energy



Contact details at:
www.geaphena.com

The specifications contained in this printing unit are intended only to serve the non-binding description of our products and services and are not subject to guarantee. Binding specifications, especially pertaining to performance data and suitability for specific operating purposes, are dependent upon the individual circumstances at the operation location and can, therefore, only be made in terms of precise requests.

Your contact:



Process Equipment Division

GEA PHE Systems NA, Inc.

100 GEA Drive
York, PA 17406
Toll Free: 1-800-774-0474
Phone: 1-717-268-6200
Fax: 1-717-268-6163
www.geaphena.com
E-mail: info@geaphena.com