

G124X | G234X | G334X
Atmospheric Gas Boilers

Buderus

Bosch Group



Setting the Standard for Efficiency

- **High Efficiency: Full line of Atmospheric Gas Boilers**
- **Flexible, Corrosion Resistant GL-180M Cast Iron**
- **Limited Lifetime Warranty**
- **Electronic Ignition, 3" Thermal Insulation on all Models**
- **74,000 to 542,000 BTU/Hr Input**

Comfortable. Efficient. Intelligent Heating.

G124X | G234X | G334X



Intelligent Heating – By Design

Buderus, the world leader in hydronic heating technology, manufactures the highest quality boilers based on centuries of experience. With its innovative design and quality manufacturing, a Buderus boiler will outlast and out-perform virtually any other residential hot water system in the world.

The G124X, G234X and G334X are designed in Europe, where fuel costs are significantly higher and

environmental regulations are more stringent. Established in 1731, Buderus uses state-of-the-art techniques in the design and manufacturing of its boilers.

Manufactured with the patented Buderus GL-180M flexible cast iron, the sections are tightly joined together and sealed by profiled, beveled steel push nipples, ensuring a long life. Special compounds provide a gas-tight seal for safe and efficient operation. And, thanks to the GL-180M cast iron's amazing flexibility, this boiler resists thermal shock under conditions of rapid temperature change. All models are atmospheric vented.

GL-180M Gray Cast Iron:

Buderus GL-180M silicone injected, gray cast iron has excellent corrosion resistance, exceptional casting characteristics and 40% greater flexibility and elasticity as well as high thermal conductivity. Buderus developed the special substances that are impregnated during the casting process to improve the mechanical properties of cast iron. The graphite precipitates into smaller, modified flakes which produce GL-180M cast iron with 40% greater elasticity and a high silicone barrier for corrosion protection. Gray cast iron obtains its superior material characteristics primarily from a high carbon (graphite) and silicone content. Additional elements further enhance the properties of the GL-180M. The graphite appears in two different forms in the microstructure: nodular form producing excellent tensile strength and great elasticity and graphite flakes producing excellent corrosion resistance against acidic combustion products. Manufactured with the patented Buderus GL-180M flexible cast iron, the sections are tightly joined together and sealed by profiled, beveled steel push nipples, ensuring a long life.

Manufactured with the patented Buderus GL-180M flexible cast iron, the sections are tightly joined together and sealed by profiled, beveled steel push nipples, ensuring a long life.



Special compounds provide a gas-tight seal for safe and efficient operation. And, thanks to the GL-180M cast iron's amazing flexibility, this boiler resists thermal shock under conditions of rapid temperature change.



Quality

Manufactured by Buderus, the world leader in cast iron boiler design and production, the G124X, G234X and G334X construction consists of flexible GL-180M cast iron, designed to resist thermal shock for long life and a high silicone cast iron surface for excellent corrosion resistance. They each have staggered contoured fins for optimum heat transfer and efficient operation, high precision castings with steel push nipples, sectional construction, and deluxe, heavy gauge blue enameled jacket for a clean finished appearance. There is a full 3" of thermal insulation for minimal standby heat loss coupled with an integral draft diverter for low profile. All models are easily converted to propane, and they also offer low emissions with Premixed Burner Technology. Durable, quiet and efficient, Buderus boilers are designed for many years of trouble-free operation.

Efficiency

The G124X, G234X, and G334X Series Boilers are available in natural gas or easily converted to propane and feature AFUE ratings up to 84.8% for high efficiency and top performance. Stainless steel premixed factory tested burners allow for low emissions, and a full 3" of thermal insulation virtually eliminate standby loss and stack temperature losses. Buderus boilers are designed for a long life, providing efficiency and durability for the homeowner that is unsurpassed by the competition.

Stainless Steel Premixed Burners

- Low emissions with Premixed Burner Technology
- Factory tested for natural gas operation
- All models easily convert to propane
- Complete burner tray is easily removed
- Durable, quiet, efficient and designed for long life

Superior Design

Flueways of Buderus boilers have a gas tight seal thanks to a tongue and groove section design and elastic high temperature resistant sealing material. This seal is fully pressed into the groove during assembly.



G234X Boiler

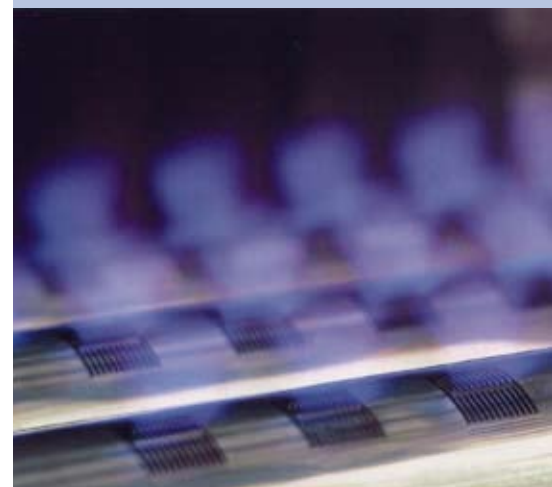

G124X | G234X | G334X

Upgrade your system for added comfort to your home!

Once you have a Buderus boiler you can add a Buderus indirect fired hot water tank, an optional Buderus Logamatic control or both. The Logamatic control maximizes your comfort and fuel savings, and it will also accommodate specialized heating applications such as radiant flooring. Combined, this premium heating system will provide years of exceptional comfort and economy...for little more than the cost of a standard replacement component.

Domestic Hot Water Tanks



The Buderus indirect fired domestic hot water tanks are designed to fit any specialized need. To maximize space, the G234X/G334X can be paired with Buderus vertical

ST-tanks. These tanks increase boiler efficiency, system longevity and minimize the need of service calls, when paired with a Buderus boiler.

The tanks are designed with many features to aid in maintenance, such as easy access ports for interior cleaning, extra thick Magnesium anode rods (or optional electrical anode) and Thermoglaze® interior tank coating to protect against corrosion and aid in cleaning. To help maximize efficiency the tanks are so well insulated against heat loss, they lose less than a ¼° F per hour.

Convenient Logamatic Control



The Buderus Logamatic Controls, designed to work with most Buderus boilers, significantly increase the efficiency of your heating system. The Controls maintain a comfortable environment by measuring indoor and outdoor temperatures in order to automatically and effectively regulate the temperature of the boiler. This allows the boiler to use less fuel while keeping your home exactly as warm as you want it. The Logamatic Controls also include the convenience of a setback feature for nighttime as well as domestic hot water priority. So, no matter how hard the heating has to work on a cold day, there will always be hot water for showers. All control functions are able to be customized by you. Additionally, the Buderus Logamatic R2107 is designed with a built-in self diagnostic system to aid in maintenance and reduce service costs.

Panel Radiators

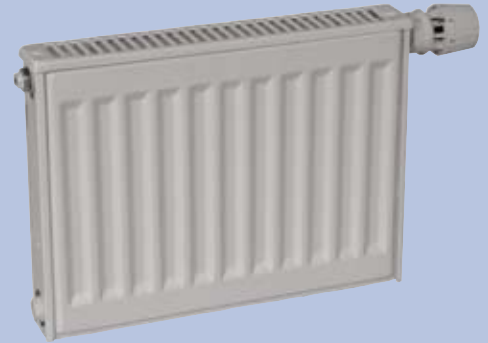

A cleaner, quieter, and more comfortable source of heat ... Buderus manufactures a whole range of high-quality radiators to precisely match your taste in decor and satisfy heating requirements. Panel radiators produce two types of heat: radiant and convected. Radiant heat like the sun warms objects rather than just the air, creating a greater sense of warmth faster and at lower room temperatures. Forced hot air or fin-tube baseboard systems only produce heat that warms the air (i.e., convected heat). The design of Buderus radiators eliminates noise, ... no more clanking and hissing. Our radiators require less space than baseboard enabling greater flexibility with furniture placement. And Buderus' unique styling also minimizes areas where dust and dirt can collect.

G124X

Model	G124X/18	G124X/25	G124X/32
Performance Data			
Input Rate BTU/Hr	74,000	103,000	132,500
DOE Heating Capacity BTU/Hr	61,400	85,500	110,000
Net IBR BTU/Hr	53,000	75,000	96,000
AFUE %	84.3	84.2	84.6
Piping Connections			
Pressure Drop @ 20° F Δ T (In WC)	18.8	22.9	32.2
B-Vent II Connection Size	5"	5"	6"
Boiler Supply & Return	1"	1"	1"
Gas Connection	½"	½"	½"
Min. Relief Valve	62 lb./hr.	86 lb./hr.	110 lb./hr.
Physical Dimensions			
Number of Burner Tubes	2	3	4
Boiler Width	23½"	23½"	23½"
Height	33⅛"	33⅛"	33⅛"
Dimension A	8¾"	5⅞"	1⅝"
Dimension B	7¼"	8⅞"	9"
Dimension C	4½"	5⅞"	5⅞"
Dimension D	15"	13½"	13½"
Dry Weight (lbs.)	229	240	337
Water Content (gal.)	2.4	2.9	3.4



G124X boilers will stack on Buderus LT160, LT200, and LT300 tanks.

Approval Numbers

MEA 100-96-E

G3-1103-58

Quick-Fit™ Modular Piping System



The Quick-Fit System takes only minutes to connect and includes all the piping, valves, circulating and control elements to feed both radiant floor heating zones and conventional high-temperature heating zones. Not only will a Quick-Fit system save time and money on any boiler installation, it also eliminates incorrect valve or motor installations. Additionally it ensures a clean, finished and professional installation. The Quick-Fit system consists of three main components, the Quick-Mix Mixing Station for radiant flooring applications, the Quick-Pump Station for high-temperature zones and the Quick-Header Manifold for multi-temp heating systems. The Quick-Fit System can be used to connect virtually any piping arrangement.

CLEARANCES:
2" FRONT
2" SIDES
6" REAR

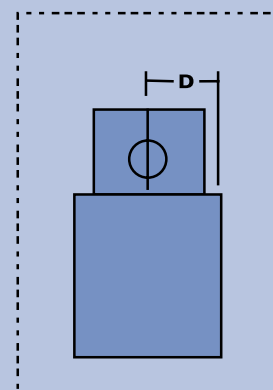
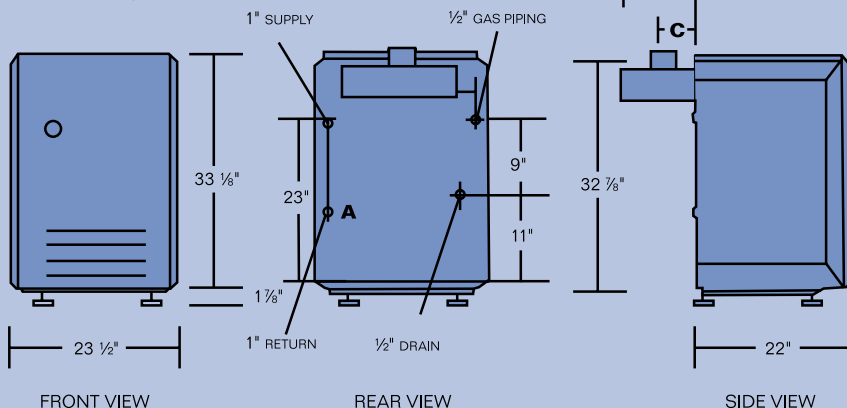

TOP VIEW

G234X

Model	G234X/38	G234X/45	G234X/55	G234X/64
Performance Data				
Input Rate BTU/Hr	160,000	187,000	228,000	266,000
DOE Heating Capacity BTU/Hr	130,000	154,000	188,000	219,000
Net IBR BTU/Hr	113,000	134,000	163,000	190,000
AFUE %	84.3	84.1	84.8	84.3
Piping Connections				
Pressure Drop @ 20° F Δ T (In WC)	16.1	22.1	25.3	28.9
Vent Size	7"	7"	7"	8"
Damper Included?	Yes	Yes	Yes	Yes
Gas Connection	¾"	¾"	¾"	¾"
Physical Dimensions				
Number of Burner Tubes	3	3	4	5
Boiler Width (W)	25 ⁹ / ₁₆ "	25 ⁹ / ₁₆ "	29 ¹ / ₈ "	32 ³ / ₄ "
Height	38 ¹ / ₂ "	38 ¹ / ₂ "	38 ¹ / ₂ "	38 ¹ / ₂ "
Dry Weight (lbs.)	487	487	562	684
Water Content (gal.)	6.1	6.1	7.1	8.2
Vent	7"	7"	7"	8"



Approval Numbers

MEA 217-98-E
CRN No# 7169.7C
G3-0106-184

CLEARANCES:
 2" FRONT
 2" SIDES
 6" REAR

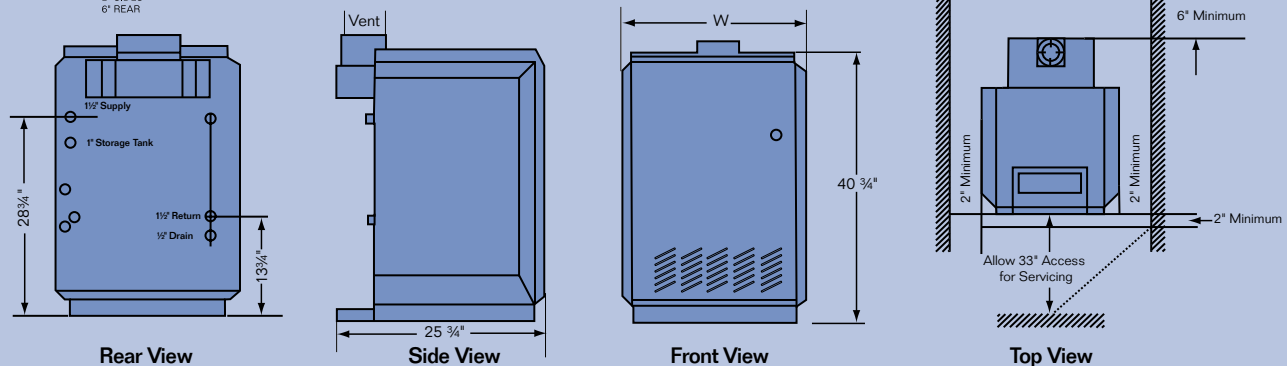

G334X

Model	G334X/73	G334X/92	G334X/116	G334X/132
Performance Data				
Input Rate BTU/Hr	301,000	378,000	476,000	542,000
DOE Heating Capacity BTU/Hr	249,000	314,000	396,000	451,000
Net IBR BTU/Hr	217,000	273,000	344,000	392,000
Comb. Eff. (%)	82.7	83.1	83.2	83.2
Piping Connections				
Pressure Drop @ 20° F Δ T (In WC)	32.1	44.1	54.2	60.2
Vent Size	8"	9"	10"	10"
Damper Included?	Optional	Optional	Optional	Optional
Gas Connection	¾"	¾"	¾"	¾"
Physical Dimensions				
Number of Burner Tubes	5	6	7	8
Boiler Width (W)	34¾"	41¾"	48¾"	56"
Height	40¾"	40¾"	40¾"	40¾"
Dry Weight (lbs.)	758	930	1,093	1,265
Water Content (gal.)	9.2	11.4	13.5	15.6
Vent	8"	9"	10"	10"



Approval Numbers

MEA 217-98-E
CRN No# 7169.7C
G3-0106-184

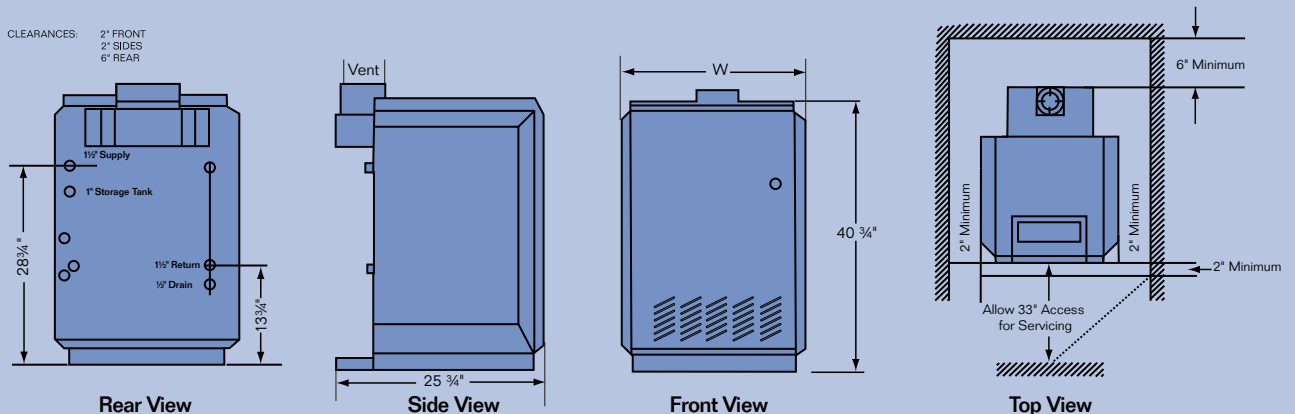

G124X | G234X | G334X: Atmospheric Gas Boilers



G334X Boiler

Buderus boilers are manufactured to the highest standards. The boilers are designed with premixed burner technology for low emissions, a factory tested gas operation, and are field converted to propane.

To aid in cleaning and servicing the burner tray is completely removable. All Buderus boilers are durable, quiet, efficient and designed for long life.

Special Features	G124X	G234X	G334X
Integral draft diverter for low profile	■	■	■
AFUE ratings over 84%	■	■	
Two stage firing capabilities			■
30 PSI relief valve, drain and P&T gauge	■	■	■
Standard non-combustible base		■	■
Approved for 2" side clearance to combustibles	■	■	■
All rear tapings for clean, finished appearance	■	■	■
Plug-in connection for vent damper	■	■	■
Boiler sizes 18 to 64 units completely assembled, jacket installed	■	■	
Combined slow opening gas control valve	■	■	■
Approved for installation on combustible flooring	■	■	■
Standard Honeywell control components	■	■	■
1" Supply and return tapings, 1/2" NPT gas connection	■		
1 1/2" Supply and return tapings, 3/4" NPT gas connection		■	■
Can be stacked on the LT Tanks	■		