

LEAVE THIS BULLETIN ON THE JOB SITE FOR FUTURE REFERENCE

The New NCM300 panel provides intelligent control of Heat Pump or Conventional forced air zoning systems at a maximum of three zones using motorized dampers and practically any off-the-shelf thermostat. With features like Automatic changeover, Timed or Thermostatic staging, Field selectable Features and Supply air Sensing capability, the NCM300 provides the highest level of performance and versatility in a non-expandable zone control panel. Perfect for new construction and retro-fit applications.

**Zone Capacity** Controls two or three air zones with 24vac Power Open/Close or Spring Assisted motorized dampers.

**Compatible HVAC Systems** Will control 1 stage Heat Pumps with Electric auxiliary heat. Will also control 1 & 2 stage Gas or Oil furnaces. Also Straight Electric furnaces or Hydronic Heat with 1 stage air conditioning.

**Compatible Thermostats** The NCM300 is compatible with most single stage Heat/Cool type Thermostats. Two stage Heat Pump Thermostats can be used if staging by temperature is desired. Hard Wired, Power Robbing or Battery Powered type thermostat models can be used.

**Automatic Heat/Cool Changeover** The NCM300 panel features automatic changeover from any thermostat allowing for individual zone comfort from the zoned HVAC system.

**Status LED** The STATUS LED blinks slowly during normal operation to indicate the micro processor is operating properly.

**System LEDs** A total of 9 LED's indicate the system status and mode of operation.

**Damper LEDs** LEDs labeled Zone 1 thru Zone 3 indicate which dampers are energized to open.

**Operating Power** **INPUT VOLTAGE:** 19-30VAC 60 Hz Transformer 40-60VA MAX. NEC Class 2. **CURRENT DRAW:** Max 14VA @ 24VAC. **OVER-CURRENT PROTECTION:** 2.5 amp or 60VA.

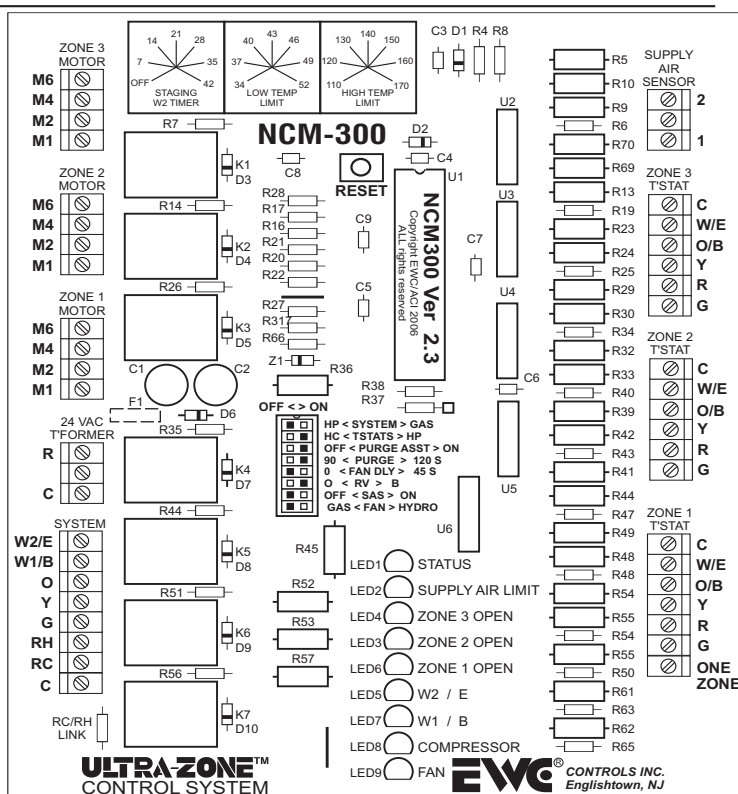

Figure 1. NCM300 panel

### Thermal Breaker

The NCM300 has a 2.5amp thermal circuit breaker in place of a fuse that protects the NCM300 from shorted circuits in the thermostat and damper field wiring. **It will not protect against shorts in the HVAC system wiring. DO NOT exceed a 60va transformer to power the panel.**

**NOTE:** When the circuit breaker is tripped it will get hot and all of the panel LED's will stop functioning. To reset the breaker, locate the short by removing all wires connected to the panel, one at a time. When the shorted wire is removed the panel will resume normal operation. Now you must repair or replace the shorted wire before you re-connect it.

### Operating Conditions

**TEMPERATURE:** -20° to 160°F (-29° to 71°C)

**HUMIDITY:** 0% - 95% RH Non-Condensing.

### Indoor Fan Control

Any zone can activate the indoor fan and only the dampers in zones calling for continuous fan operation will open. Continuous fan operation will only occur when there are no active or pending heat or cool demands.

## Built-In Timer Settings

The panel has built-in timers that insure safe HVAC system operations.

- \*Start-up Delay Timer 4 minutes, fixed.
- \*Minimum Run Timer 2 minutes, fixed.
- \*Short Cycle Timer 2 minutes, fixed.
- \*Changeover Timer 4 minutes, fixed.
- \*Opposing System Service Timer 20 minutes, fixed.
- \*Second Stage Heating Timer Off or 7 to 42 minutes, adjustable.

### TIMER DEFINITIONS

#### Start-Up Delay Timer

Upon initial power up or after a power failure, the panel will not start the equipment for 4 minutes.

#### Minimum Run Timer

When a call is activated, the zone panel will run the HVAC system in that mode for a minimum of 2 minutes.

#### Short Cycle Timer

When the HVAC system is satisfied, the zone panel will not resume the same call for a minimum of 2 minutes.

#### Changeover Timer

At the end of a call, a 4 minute timer is started and the zone panel will not switch to the opposite mode of operation until the timer has expired.

#### Opposing System Service Timer

A 20 minute delay must expire, or the active zone(s) must satisfy, before the panel will honor a thermostat demand to changeover to the opposite mode of system operation.

#### 2nd Stage Heating Timer

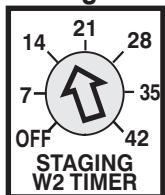

The W2 TIMER sets the total amount of time delay before second stage heating is energized. 1st stage heat will stay energized when 2nd stage heat activates. If desired turn the Timer OFF and let your heat pump thermostats stage up for you.

#### Heating and Cooling Limit Settings

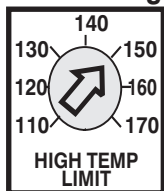

The Heating Limit potentiometer sets the supply air temperature at which the heating is cycled off and the fan continues to run until, the supply air temperature has dropped below the heating limit set point. 3 Minutes min.

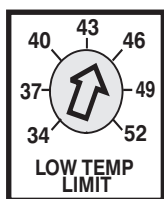

The Cooling Limit potentiometer sets the supply air temperature at which the cooling is cycled off and the fan continues to run until, the supply air temperature has risen above the cooling limit set point. 3 Minutes min.

## RESET BUTTON



### RESET

Reset the CPU *anytime* you make dip-switch changes to the NCM300 panel!

DO NOT use a sharp object to press the button! Your finger tip will work fine.

Momentarily pressing the RESET button clears the built-in timers controlling the Start-up timer, Minimum run timer, Short cycle timer, W2 timer, Supply air sensor timer and the Changeover timer. This enables you to test the installation faster. Caution should be observed when using this button.

**Pressing the RESET button for 7 seconds will reset the CPU.**

## Selecting the Options Using the DIP Switches

8 DIP switches allow you to select the features specific to your very own zoned HVAC system.

### HP < SYSTEM > GAS



Select the type of HVAC system the panel will control. Heat Pump (HP) or Gas/Oil/Hydronic with A/C. (GAS)

### HC < TSTATS > HP



Select the type of Thermostats you will use. Select HC for conventional Heat/Cool type thermostats or select HP for Heat Pump type thermostats.

### OFF < PURGE ASST > ON



Select ON to allow the NCM300 to operate the fan during the 90/120 second purge cycle. Works in both heat and cool mode. Set the switch to OFF to allow the system to operate on it's own fan purge cycle.

### 90 < PURGE > 120s



Select a purge time of 90 seconds or 120 seconds. The damper(s) on the last zone calling will be held open for that time while all other zone dampers remain closed.

### 0 < FAN DLY > 45S



Select 45 seconds to allow the hot water or steam coil to heat up before the fan starts. Select 0 seconds and the fan will start immediately upon a call for heat. **Switch # 8 must be set to HYDRO for this feature to work!**

### 0 < RV > B



Select O or B for the type of Reversing Valve operation of your heat pump.

### OFF < SAS > ON



Select ON if you are using a Supply Air Sensor with the NCM300. Select OFF if you have not installed a sensor.

### GAS < FAN > HYDRO



Select the GAS position when setting up for gas or heat pump systems. Select HYDRO when setting up for Straight Electric or Hydronic (Steam/Hot Water) heating systems.

# WIRING INSTRUCTIONS

**WARNING: THESE PANELS ARE DESIGNED FOR USE WITH 24VAC. DO NOT USE OTHER VOLTAGES! USE CAUTION TO AVOID ELECTRIC SHOCK OR EQUIPMENT DAMAGE. ALL WORK SHOULD BE PERFORMED TO LOCAL AND NATIONAL CODES AND ORDINANCES. USE 18 AWG SOLID COPPER, COLOR-CODED, MULTI-CONDUCTOR THERMOSTAT CABLE.**

## Thermostat Wiring

**The NCM300 zone control panel requires standard 1 stage heat/cool thermostats in all zones, regardless of the application. 2nd stage heat output is controlled by an adjustable timer on the panel. If you prefer, the NCM300 will also work with any off the shelf 2 stage Heat Pump Thermostat. 2nd stage heat will then be thermostatically controlled. Typical thermostat wiring diagrams are shown below.**

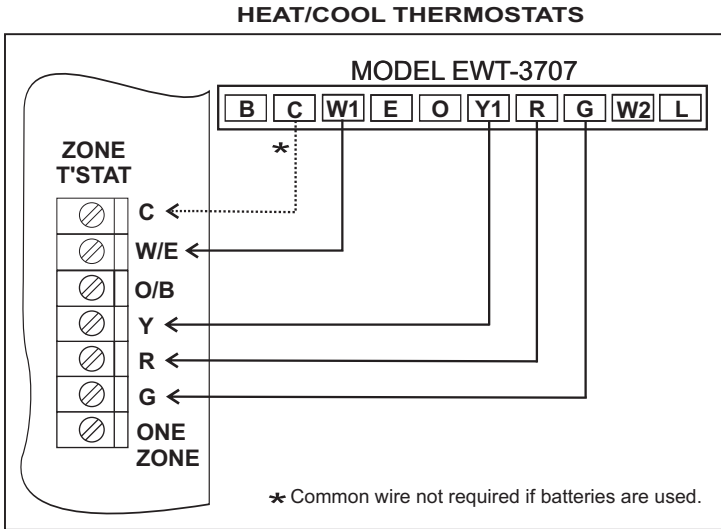

Figure 2a. Model EWT-3707: Configured for 1 heat 1 cool (SS1 mode). See thermostat instructions for further details.

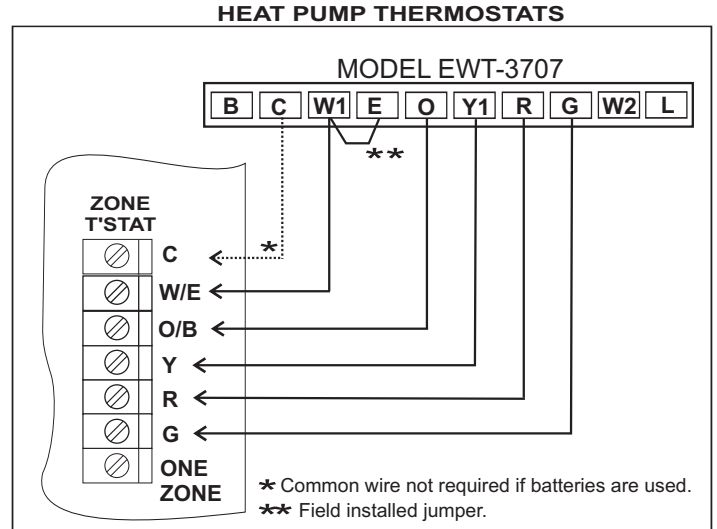

Figure 2c. Model EWT-3707: configured for 2 heat 1 cool heat pump (HP1 mode). See thermostat instructions for further details.

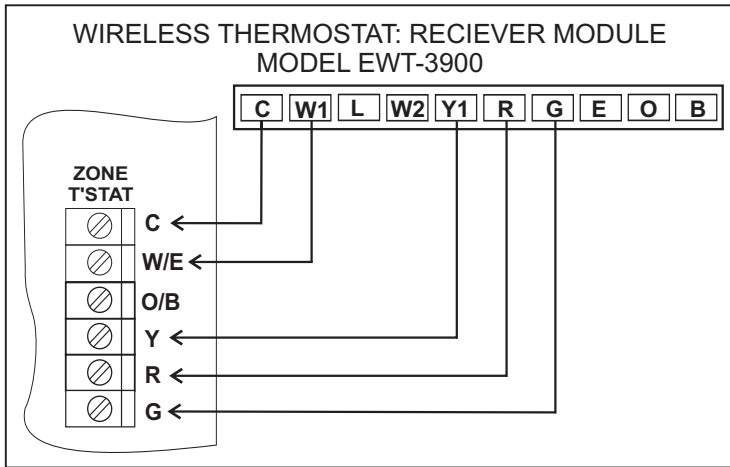

Figure 2b. Model EWT-3900: Wireless Thermostat. Configured for 1 heat 1 cool (SS1 mode). Can be configured for heat pump. See

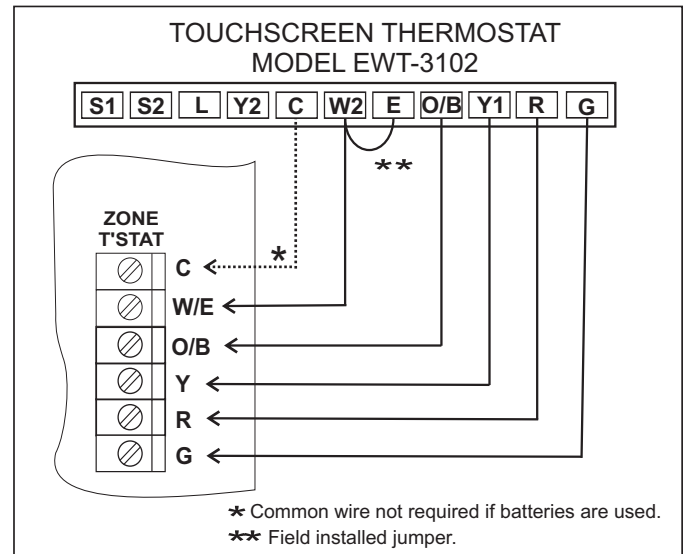

Figure 2d. Model EWT-3900 Wireless Thermostat: Configured for 2 heat 1 cool heat pump (HP1 Mode). See thermostat instructions for further Details.

**NOTE: The New NCM300 allows the user to install Heat Pump thermostats on all zones. This allows the user to override the W2 Timer and energize the auxiliary heat via thermostatic demand! You may still use regular Heat/Cool type thermostats with a Heat Pump system and use the W2 Timer to energize the auxiliary heat. Doing so may save more energy. This new design simplifies the thermostat selection process and allows the installer to easily adapt the NCM300 to most residential applications.**

## System Wiring

The NCM300 panel was designed to be easy to understand and wire up. We have provided several typical field wiring diagrams to review. Your actual field wiring may vary. Notice that you may now connect the 24vac "C" common terminal from the HVAC system to the NCM300 "system" terminal block. This provides a convenient place to reference the HVAC system 24vac common wire and helps to simplify the troubleshooting process.

### Single Transformer Gas/Electric Systems

Typical gas/electric system showing 1 or 2 stage heating. **Note the jumper (link) between RC and RH.** There is no need to install your own jumper.

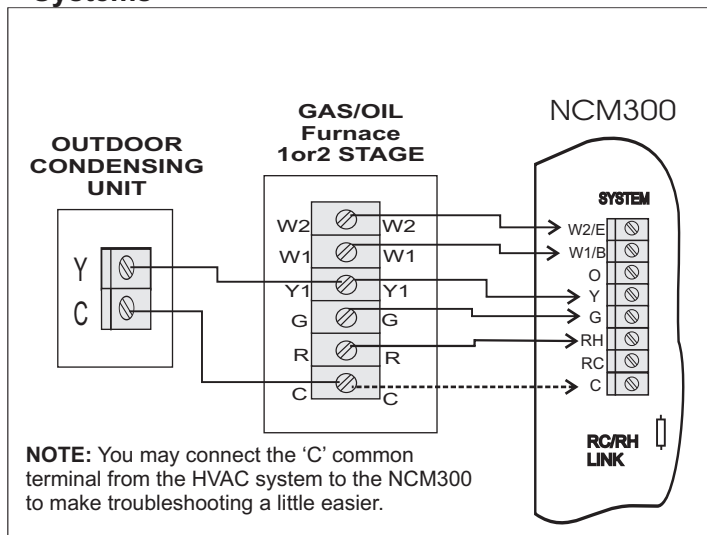

Figure 3a.

**Note:** Your Hydronic Air Handler may include a W terminal. That means it may have it's own isolation circuit. If you can confirm this, simply connect the W1/B terminal to the W terminal on the air handler. **Do not cut the Rc/Rh Link.** Wire up your Boiler Control or Circulator Control to the isolation contacts or wires provided in the air handler. (Follow dashed lines) The fan is controlled via time delay relay inside the air handler or use the Fan Hydro switch on the NCM300.

### Two Transformer Hydronic Heat Systems

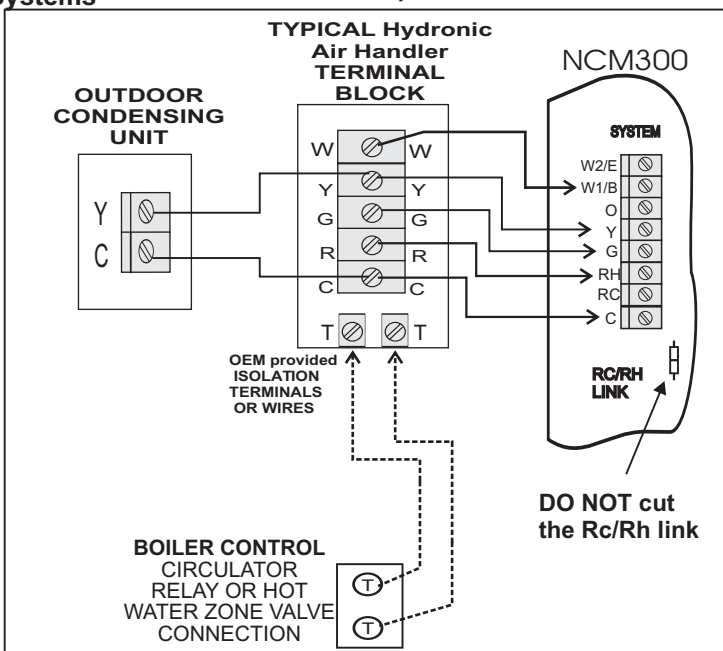

Figure 3b.

### Heat Pump with O or B Type Reversing Valve

Typical heat pump system wiring with electric resistance backup heat. Wire up the reversing valve to either O or W1/B, depending on your type of system. Applies to air cooled or geothermal / ground source HVAC systems.

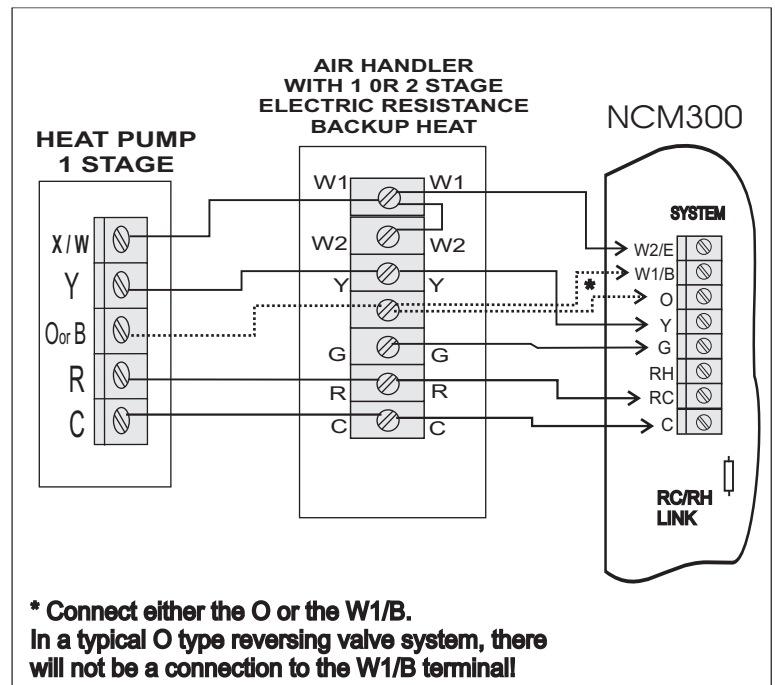

Figure 3c.

### Two Transformer Oil Heating Systems

Your Oil furnace may not provide factory isolation for the Primary Burner Control. Simply cut the Rc/Rh link on the NCM300 and wire up to the Fan Center as shown. Then run the T&T connections to the Rh and the W1/B terminals to complete the control wiring.

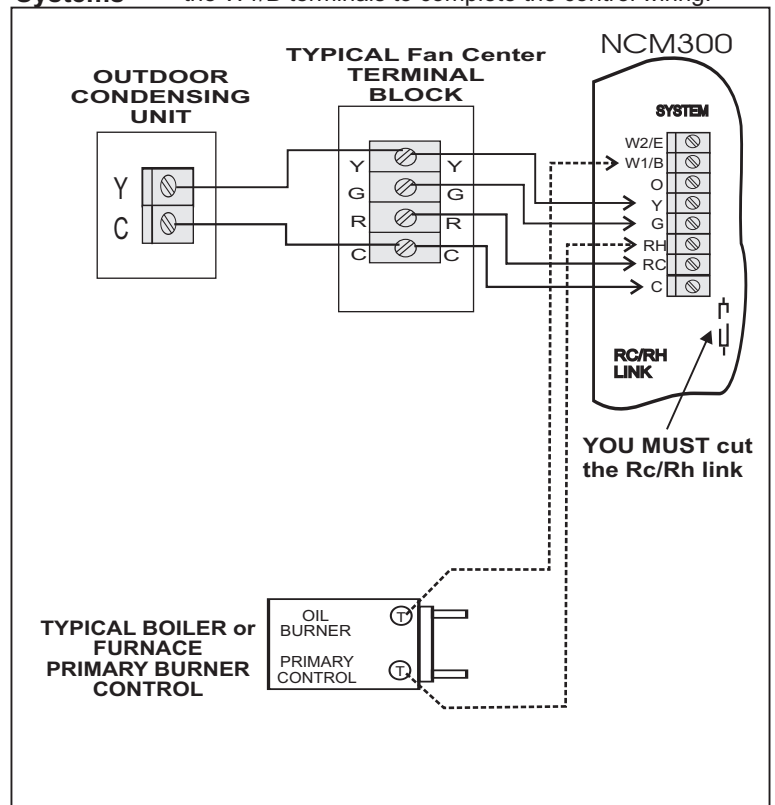

Figure 3d.

# DAMPER WIRING

**Note: All zone dampers default to the "OPEN" position after a purge delay has occurred. Dampers also default "OPEN" during changeover & short cycle delays, and when all zone demands are satisfied, and no signals are detected from the thermostats.**

REFERENCE THESE DIAGRAMS PRIOR TO INSTALLATION AND POWER WIRING. DOING SO WILL SAVE TIME AND LABOR LATER ON.

## ZONE DAMPER MOTOR TERMINAL BLOCK DESIGNATION & FUNCTION

- Terminal M6 24vac to Close a damper(s)
- Terminal M4 24vac to Open a damper(s)
- Terminal M2 Constant 24vac HOT
- Terminal M1 Common 24vac

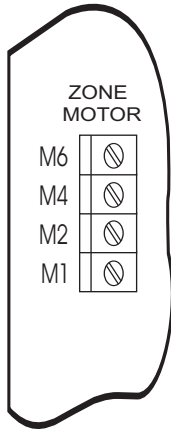

Figure 4a

## All Models ND & URD Damper Wiring

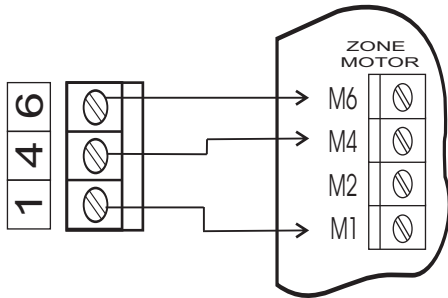

Figure 4b

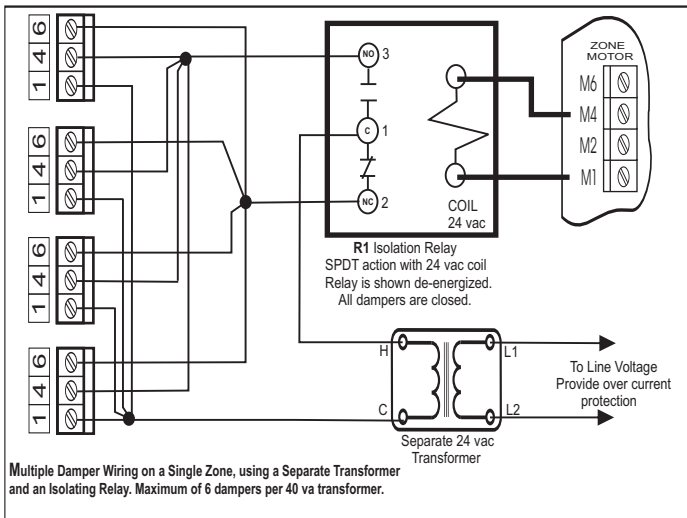

Figure 4c

## 2 Wire Spring Return Motor Wiring

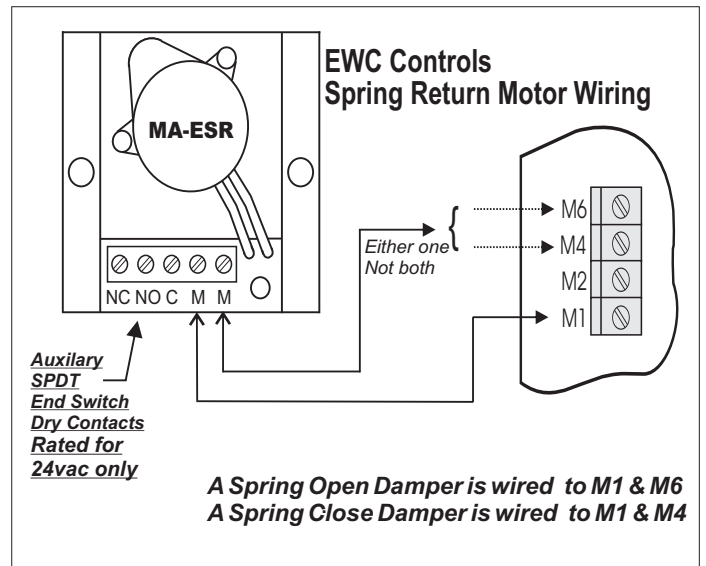

Figure 5

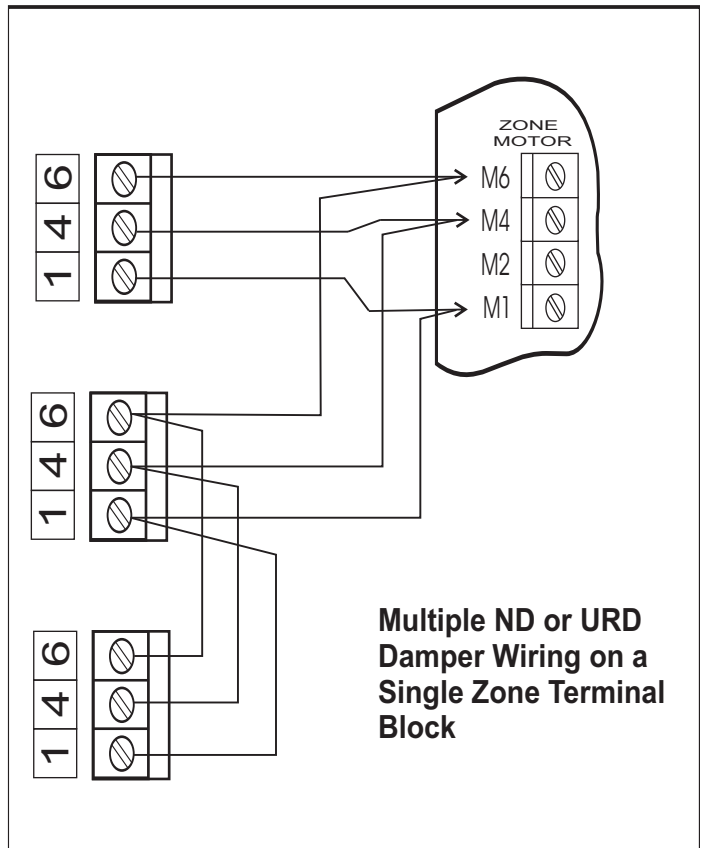

Figure 6

***On all these dampers and most older style dampers, including competitor's dampers, always wire up number to number.***

***Do not overload the NCM300 Thermal Circuit Breaker. Use a 24vac UL listed transformer at 60va maximum power rating!***

# SERVICE GUIDE

## Some Helpful Guidelines

All voltage measurements on the NCM300 panel should be made with the ground lead of your meter on terminal “C” of the 24VAC input terminals.

All voltage measurements at the **HVAC System Terminal Block** (W1/B, O, Y, W2/E & G) should be made with the meter’s ground lead on the terminal “C” at the HVAC system block.

## Using the LED Indicators

The **STATUS LED** should blink at 1second on / 1 second off, to indicate the microprocessor is operating properly.

The **SUPPLY AIR LIMIT LED** will illuminate if the panel senses a discharge temperature in excess of the high or low limit set points. The LED will blink rapidly if the sensor is open, shorted or disconnected. The panel will function normally but with no supply air temperature control until the open or short is repaired.

The **Zone Damper LED’s** will illuminate to indicate which dampers should be open.

The **W1/B LED** indicates that the panel is in the 1st stage heating mode or, the “B” type reversing valve output is active.

The **W2/E LED** indicates 2nd stage heat or Emergency heat has been energized.

The **COMPRESSOR LED** indicates the compressor is energized.

The **FAN LED** indicates the fan is energized.

## Dampers Not Responding Properly

If the Zone LED indicators are illuminated but the dampers appear to be malfunctioning, check the damper field wiring.

If the ZONE LED’s are not responding properly, check the calls on each zone thermostat. If the calls indicate a damper should be energized and is not, press the RESET button to cancel the timers. If the problem persists, see Table 2 for service help.

## Check 24VAC Power

Measure 24VAC at all damper **M1** and **M2** terminals and all T-stat **R** and **C** terminals. See Table 1 if any of these voltages are incorrect.

## HVAC System Not Responding Properly

If the HVAC LED indicators are responding properly, but the system appears to be malfunctioning, check that the HVAC system is wired correctly and that the DIP switches have been properly set.

If the HVAC LEDs are not responding properly, check the calls on each zone thermostat. If the calls indicate that the HVAC system should be activated and is not, press the RESET switch to cancel the timers. Also check that the DIP switches have been properly set. If the problem persists, see Table 3 for trouble shooting help.

## Table 1. Detecting 24VAC Shorts

### Detecting 24vac Shorts

**All LED’s will be off and the panel will appear to be dead!** you will measure 24VAC at the transformer terminals **R & C**, but not at any damper **M1&M2** terminals, or any zone thermostat **R & C** terminals. **CAUTION:** The thermal breaker will be hot to the touch.

### Isolating 24vac Shorts

Remove the power to the panel and allow the thermal poly fuse to cool down.

Remove the wire at each zone thermostat **R** terminal and test if the short still persists by restoring power to the zone panel and testing as described above. If the short disappears, check the zone thermostat wiring and the thermostat itself. This applies if the thermostat requires the 24 volt (**C**) common, or the **R** wire could be shorted to the building ground.

If the short still persists disconnect all the wires at each damper terminal (M1, M2, M4 & M6). Restore power and test as described above. If the short clears, check the damper wiring and the dampers for shorts with a continuity tester. If the short still persists, call the technical support hot-line.

**Table 2. Detecting Damper Problems**

<b>Damper LED On But Damper Not Responding</b>	Check the damper wiring to insure it is correctly wired. Be sure the wires are secured in the terminals. Test the damper motor to insure it is properly operating. If the problem still persists, contact technical support.	<b>Testing Damper Motors</b>	For a RDN/SMDL/BMDL damper, connect 24VAC common to terminal <b>1</b> , and 24VAC to terminals <b>2</b> and <b>4</b> . The damper should open. Remove 24VAC from terminal <b>4</b> and the damper should close.
<b>NCM300 Damper LED Not Responding</b>	<p>Check that the STATUS LED is blinking. If it is not, the panel may be in a shutdown mode due to a short in the field wiring. See Table 1. Detecting 24vac shorts.</p> <p><b>Press the RESET for 1 second to clear any time delay(s) that may be keeping the call off and the damper from not responding.</b></p> <p>Check the voltage at each zone thermostat terminal <b>W</b>, <b>Y</b> and <b>G</b> terminals to insure the damper should be activated.</p> <p>If the problem still persists, call the technical support hot-line.</p>	For a BMD/SMD/ND/URD damper, connect 24VAC common to terminal <b>1</b> , and 24VAC to terminal <b>4</b> and the damper should open. Remove 24VAC from terminal <b>4</b> and apply 24VAC to terminal <b>6</b> and the damper should close.	For a power close spring open damper, connect 24VAC to the two motor " <b>M</b> " terminals, and the damper should CLOSE. Remove the 24VAC and the damper should OPEN. For a power open damper, the action will be reversed.

**Table 3. Detecting Heating, Cooling and Fan Problems**

<b>Panel LEDs On But System Not Responding</b>	<p>Check the HVAC wiring to insure it is correctly wired. Be sure the wires are secured in the terminals. Check that there is 24VAC at the <b>Rc</b> and <b>Rh</b> terminals. Use the HVAC system common (C) for the ground lead of your meter. Check that Rh and Rc are connected if the system uses a single transformer.</p> <p>For a gas/electric system test the HVAC by shorting terminals <b>Rh</b> and <b>W1/B</b> together to activate the heater, <b>Rc</b> to <b>Y</b> to activate the compressor and <b>Rc</b> to <b>G</b> to activate the fan. If the HVAC system has responded properly, call EWC technical support.</p> <p>For a heat pump system test the heating by jumping terminals <b>Rc</b> to <b>Y</b>, <b>W1/B</b> and <b>G</b>. For a cooling test jump <b>Rc</b> to <b>Y</b>, <b>O</b> and <b>G</b>.</p>	<p>Press the RESET button for 1 second to clear the time delay that may be preventing the call. The panel could be in minimum run time, short cycle delay, changeover delay or opposite system timing mode.</p> <p>If the system still does not respond, measure the voltage at each zone thermostat terminal <b>W/E</b>, <b>Y</b>, &amp; <b>G</b> to insure they are correct and a call is in order.</p>	
<b>LEDs and System Not Responding</b>	<p>Check that the STATUS LED is blinking to insure the computer is operating properly, <b>press and hold the RESET button for 7 seconds to reboot the CPU.</b></p>	<b>Measuring Thermostat Voltages</b>	<p>Heat/Cool thermostats will apply 24vac to the <b>W/E</b> terminal during a heating call. During a cooling call, 24vac is applied to both <b>Y</b> &amp; <b>G</b>. During a continuous fan call, 24VAC is applied to the G terminal.</p> <p>Be sure the <b>Rc</b> and <b>Rh</b> terminals at the thermostats are jumped together if your specific installation requires it.</p> <p>Heat Pump thermostats will apply 24vac to <b>Y</b> and <b>G</b> during a 1st stage heating call. 24vac will be applied to <b>W/E</b> during a 2nd stage call. In Emergency mode, 24vac is applied to <b>W/E</b> &amp; <b>G</b>. During a cooling call, 24vac is applied to <b>Y</b>, <b>G</b> &amp; <b>O</b>.</p>

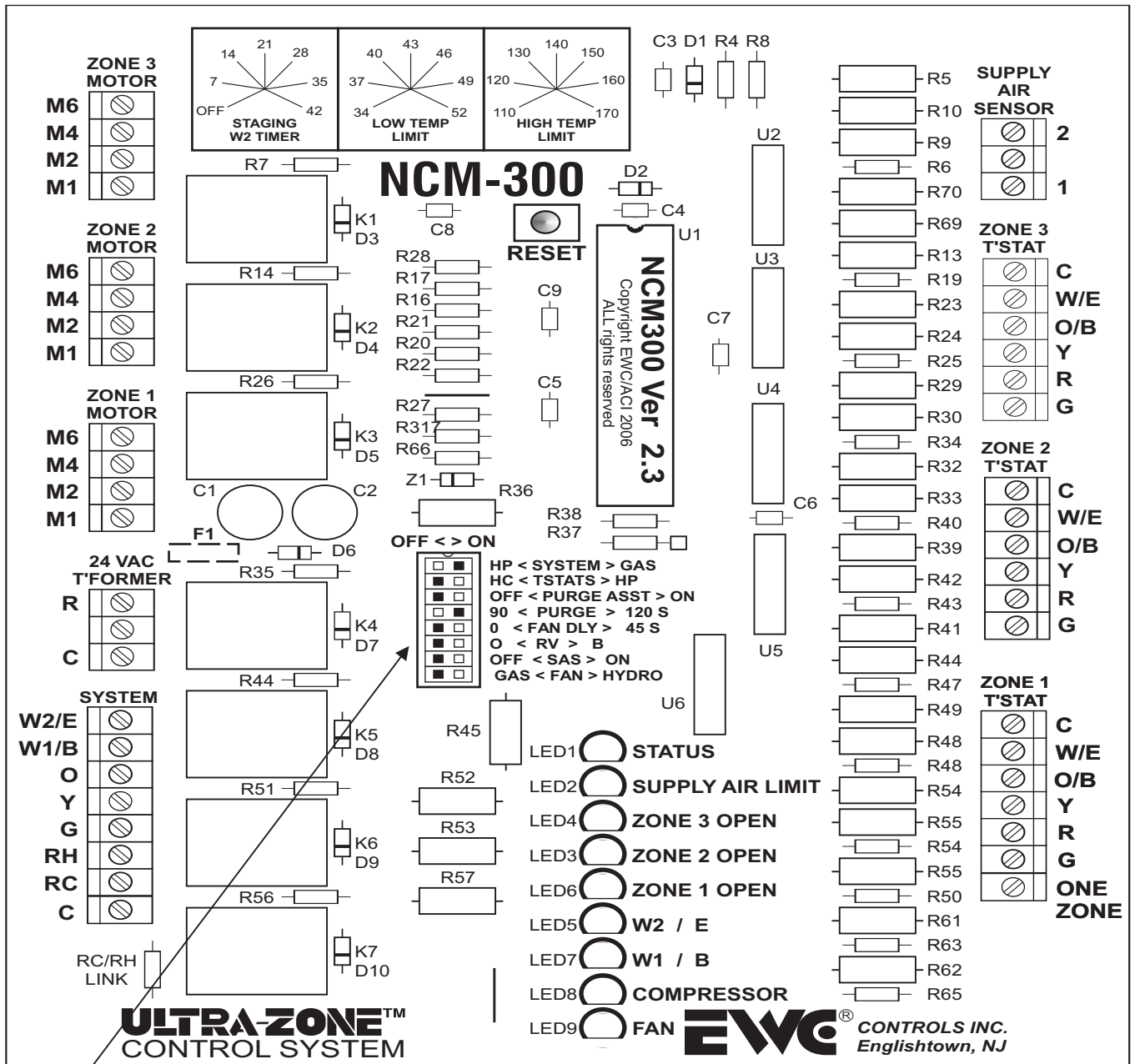

***Blow-up view of NCM300 showing Factory Dip Switch settings.***

**OFF < > ON**

RECORD YOUR OWN DIP SWITCH SETTINGS HERE →

Use a pencil and shade the boxes that correspond to your settings!

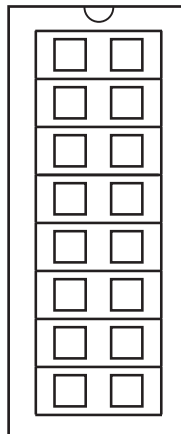

**HP < SYSTEM > GAS  
 HC < TSTATS > HP  
 OFF < PURGE ASST > ON  
 90 < PURGE > 120 S  
 0 < FAN DLY > 45 S  
 0 < RV > B  
 OFF < SAS > ON  
 GAS < FAN > HYDRO**



# HEAT / COOL WIRING DIAGRAM

## Model NCM-300 ULTRAZONE™ Control Panel

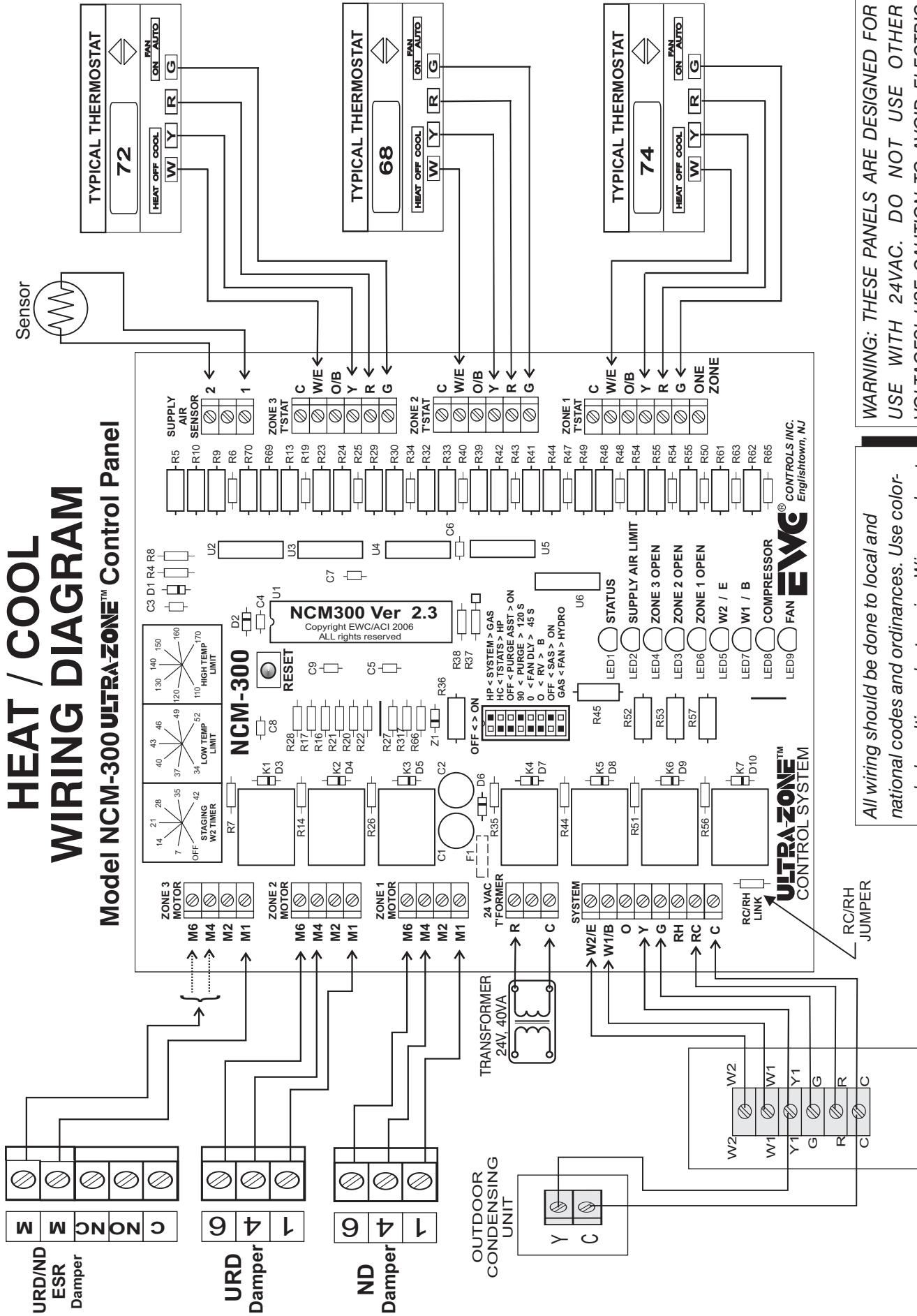

**WARNING: THESE PANELS ARE DESIGNED FOR USE WITH 24VAC. DO NOT USE OTHER VOLTAGES! USE CAUTION TO AVOID ELECTRIC SHOCK OR EQUIPMENT DAMAGE.**

All wiring should be done to local and national codes and ordinances. Use color-coded, multi-conductor wire. Wire number to number or letter to letter on each control.

# HEAT PUMP WIRING DIAGRAM

## Model NCM-300 ULTRAZONE™ Control Panel

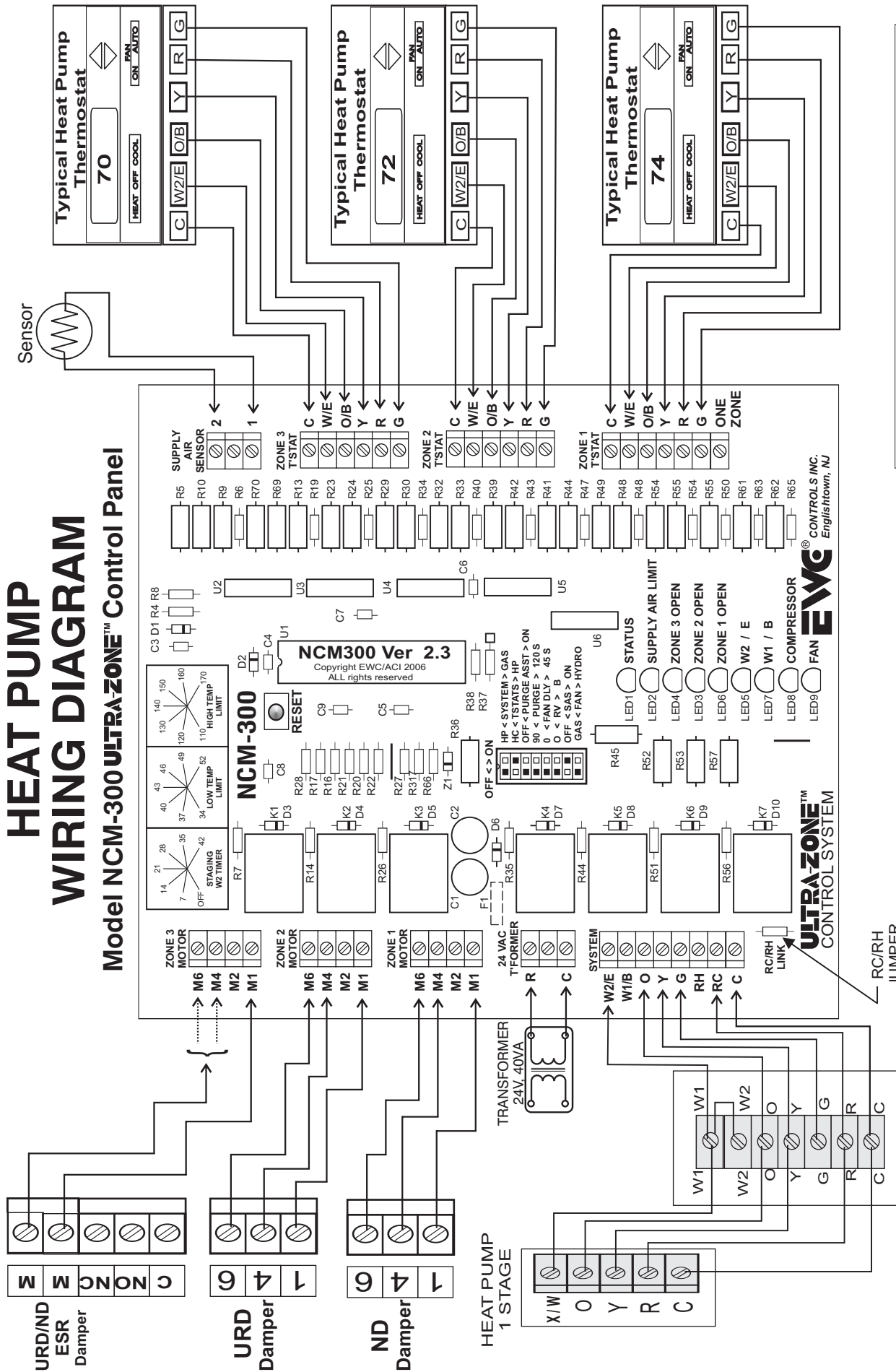

All wiring should be done to local and national codes and ordinances. Use color-coded, multi-conductor wire. Wire number to number or letter to letter on each control.

WARNING: THESE PANELS ARE DESIGNED FOR USE WITH 24VAC. DO NOT USE OTHER VOLTAGES! USE CAUTION TO AVOID ELECTRIC SHOCK OR EQUIPMENT DAMAGE.

PIN 090375A0206 REV C

# ULTRA-ZONE™

## Forced Air Zone Controls

### SUPPLY AIR SENSOR OPERATIONS AND ONE ZONE FEATURE CONTROL

A *Supply Air Sensor* can be used to limit supply air temperatures and prevent over heating of the equipment during the heating cycle or coil freeze-up during cooling cycles. Wire the sensor as shown below and set dip switch #7 to the *ON* position. (See Page 2)

The Supply air sensor installs into the supply air plenum or downstream of the evaporator coil or heat exchanger and monitors the discharge air temperature in heating and cooling modes. The actual temperature is relayed backed to the microprocessor. When the temperature exceeds or falls below the HEAT or COOL limit set points, the microprocessor will de-energize all HEAT or COOL outputs for a minimum of 3 minutes. It also energizes the FAN, if it is not already running, to help dissipate the heat or warm up the evaporator coil. Refer to the Data sheet that comes with the Supply Air Sensor.

*There is no differential built in to the sensor!* Once the supply air temperature rises or falls to a safe value and, the 3 minute time delay has expired, the microprocessor will restore the HEAT or COOL outputs. The FAN will de-energize or stay running, depending on the mode of operation and the application.

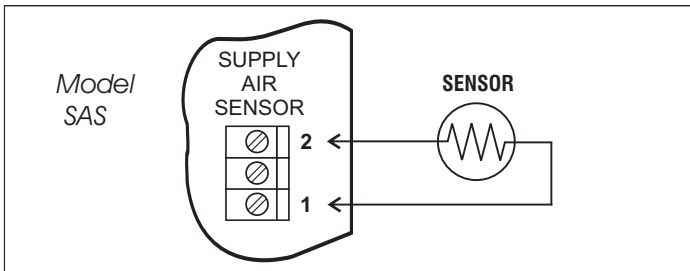

Supply air temperature sensor.

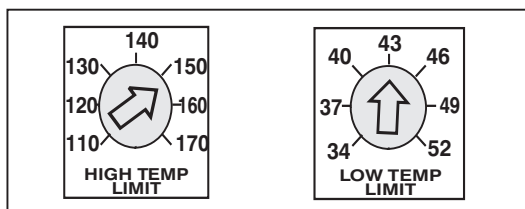

Adjustable Heating & Cooling limit potentiometers

The *One Zone* feature allows the homeowner to control all the zones from a single thermostat by using an optional switch connected to the One Zone terminal shown below. A homeowner can switch to One Zone control when they leave for vacation or as a night setback mode, and the Zone 1 thermostat will control all zones. All zone dampers will respond to the Zone 1 thermostat. Use Part # VAC.

One Zone can also be used in commercial applications with a programmable thermostat in Zone 1 and non-programmable thermostats in all other zones, thus satisfying the requirements of California Title 24.

Substantial energy savings and equipment protection can be obtained with proper use of the One Zone feature and the supply air sensor.

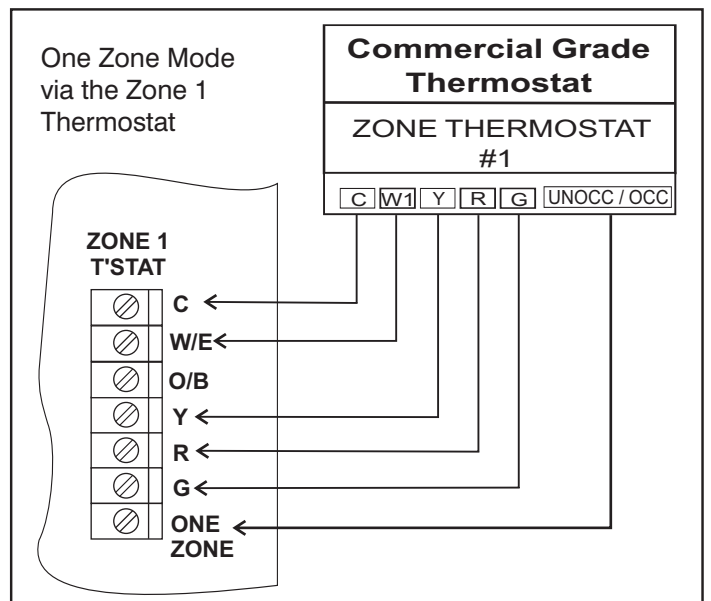
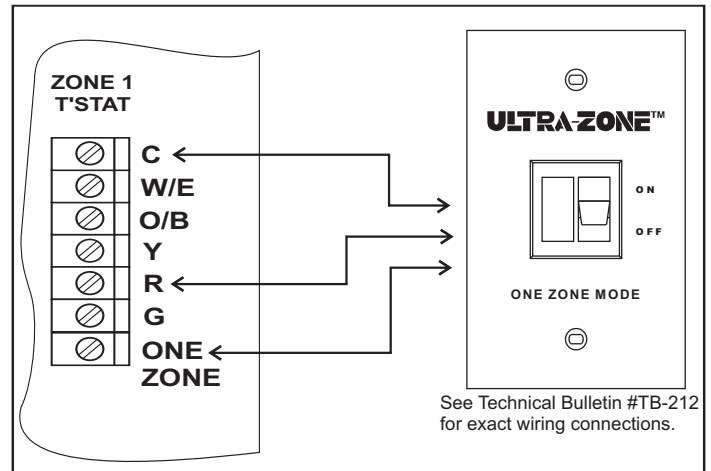



**Congratulations on purchasing and successfully installing your new NCM300 Zone Control system. The NCM300 is certainly easy to setup and install. But should you find the need for a little assistance, remember that you can call our toll free technical support hotline when you are on the job site! @ 800-446-3110. Please have a multi-meter, pocket screwdriver and wire cutters handy.**

**If you just have some questions about the NCM300 or any other Ultra-Zone product, call us at 732-446-3110. Monday thru Friday, 8:00am - 5:00pm Eastern Time.**

**Thank You**

**FIELD NOTES:**