

**Electronic Programmable Controller
Six Stage, Dual Setpoint
General Instructions**

APPLICATION

Electronic six stage programmable controller with proportional output for heating, cooling and mixed air. The six stages can be programmed for heating, cooling and fan operation.

SPECIFICATIONS

Sequenced Control: Staged and/or proportional heating, proportional control of outside and return (mixed air) damper, staged and/or proportional cooling. Heating and cooling cannot operate simultaneously.

Single Sensor Control: Heating, cooling and ventilation with individual heating and cooling setpoints.

Unit Fan: May be programmed to cycle in the unoccupied mode.

Relay Output: 6 relays can be programmed for heating, cooling or fan operation. Operational voltage level by dual-in-line switches.

Mixed Air Sensor (optional): The controller can provide a separate mixed air control, or limit control in conjunction with proportional cooling output ramp.

Cold Start: On power failure.

Sensors: Any non-adjustable TS-8000, or TS-80000 Balco sensor.

Control Output Voltage: See Table-2.

Power Requirements: 24 Vac, 10 VA.

Power Supplies Available: 6.2 Vdc, 4 mA; 20 Vdc, 35 mA. These regulated and filtered power supplies must not be connected to +20, +6.2 or red lead of other supplies.

Environment:

Ambient Temperature Limits,

Shipping and Storage, -40 to 160°F (-40 to 71°C).

Operating, 0 to 140°F (-18 to 60°C).

Humidity, 5 to 95% RH, non-condensing.

Locations, NEMA Type 1 indoor only.

Connections: Coded screw terminals.

Cover: Aluminum.

Mounting: Unit is provided with plastic track for panel mounting.

Dimensions: 3-7/8" high x 12" wide x 2-3/4" deep (98 mm x 305 mm x 70 mm).

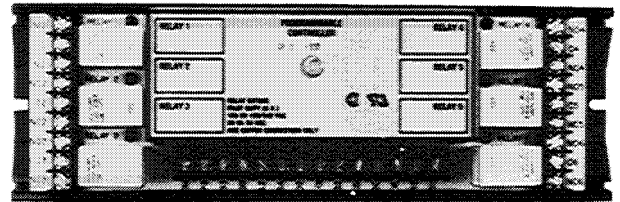

OPTIONS

CP-8161-433 CP-8161-333 less controller board. Used as slave in conjunction with CP-8161-333, CP-8261-333 or with TP-8121 or TP-8124.

ACCESSORIES

- AD-8969-201 Offset resistor kit; 5, 10, 15, and 20 °F
- AT-8122 Remote setpoint adjuster, dual scale 20 to 120°F (-6 to 49°C)
- AT-8155 Remote setpoint adjuster, dual scale 50 to 250°F (10 to 120 °C)
- AT-8158 Remote setpoint adjuster, dual scale 55 to 85°F (13 to 29 °C)
- AT-8258-101 Night setback scale for AT-8158
- TC-4111 Bulb thermostat
- THC-2 Enthalpy controller
- TS-8101 Room sensor
- TS-8131 Room button-type sensor
- TS-8201 Duct/immersion sensor
- TS-8241 Diffuser sensor
- TS-8261 Light fixture sensor
- TS-8405 5' (1.5 m) averaging sensor
- TS-8422 22' (6.7 m) averaging sensor
- TS-8501 Outdoor sensor
- TS-8601 Selective ratio discharge sensor
- TS-810X1 Ser. Room temperature sensors
- TSP-8101-103 Temperature transmitter
- TOOL-201 Calibration kit for TAC System 8000

Table-1 RELAY CONTACT RATINGS.

Volts AC 50/60 Hz	Contact	VA Rating	Inrush VA
120/240	N.O.	125	1250
	N.C.	67	670
24	N.O.	25	250
	N.C.	13	130

Table-2 SPECIFICATIONS.

Part Number	Heating			Cooling			Mixed Air ^a				Relay (6) Outputs	
	Setpoint "SPA"	Throttling "TRA" ^b	Output "IO1"	Setpoint "SPB"	Throttling "TRB" ^b	Output "IO2"	Low Limit Setpoint ^c	Minimum Position	Mixed Air Start Point	Output "OP3"	Pull-in Voltage (Vdc)	Differential
CP-8161-333	45 to 75 °F (7 to 24 °C)	2 to 10 °F Factory Set 3°F	2 to 15 Vdc Factory set R.A. Field changeable D.A.	70 to 100 °F (21 to 38 °C)	2 to 10 °F Factory Set 3°F	2 to 15 Vdc D.A. only	41 to 95 °F (5 to 35 °C) 10°F ^b fixed T.R.	0 to 100% Factory set 25%	3 to 6 Vdc with respect to CLG output (Output is 6 to 9 Vdc)	5 to 12 Vdc D.A. only	5.5 6.5 7 7.5 8 8.5 9	0.5 Vdc fixed
CP-8161-433	None	None	^d	None	None	^d						

- ^a Mixed air override is either accomplished from first or second stage cooling, or by outside enthalpy or temperature thermostats (purchased separately).
- ^b For 3 Vdc output change.
- ^c Can be used as separate mixed air controller or mixed air low limit in conjunction with cooling output ramp (then throttling range of mixed air would be the same as cooling ramp).
- ^d IO1 and IO2 become inputs on CP-8161-433.

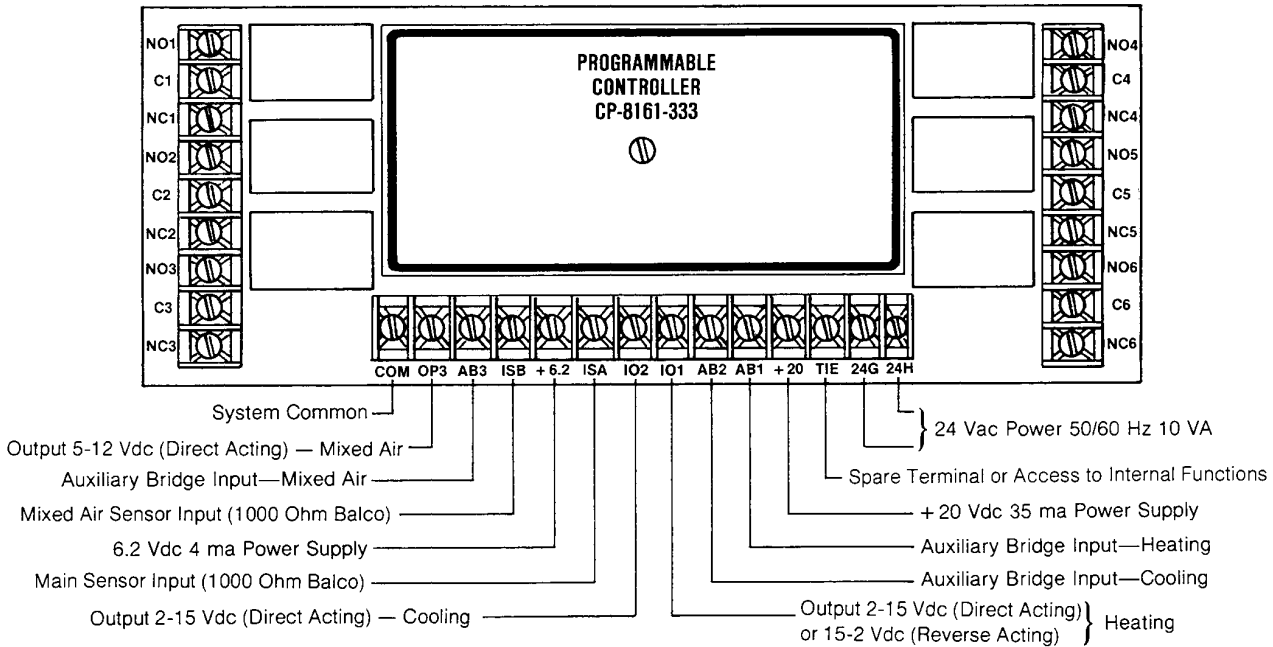

Figure-1

DEFINITIONS

Direct-Acting (D.A.) Control Temperature increase at main temperature sensor causes the output voltage signal to increase, therefore causing the relays to energize.

Reverse-Acting (R.A.) Control Temperature increase at main temperature sensor causes the output voltage signal to decrease, therefore causing the relays to de-energize.

Throttling Range (T.R.) Number of degrees change required at the main temperature sensor in order to produce a 6 to 9 Vdc (3 Vdc) proportional signal output change.

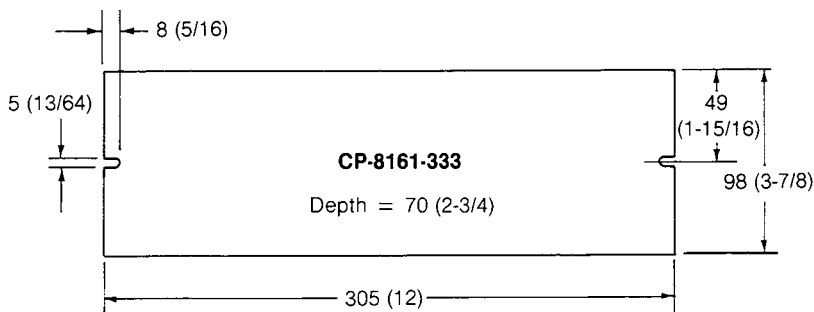

All dimensions in millimeters with inches shown in brackets.

Figure-2

CP-8161-333
3-Heat/3-Cool/Mixed Air
(Showing Program as Shipped from Factory)
 See Figure 10 for Sequence of Operation

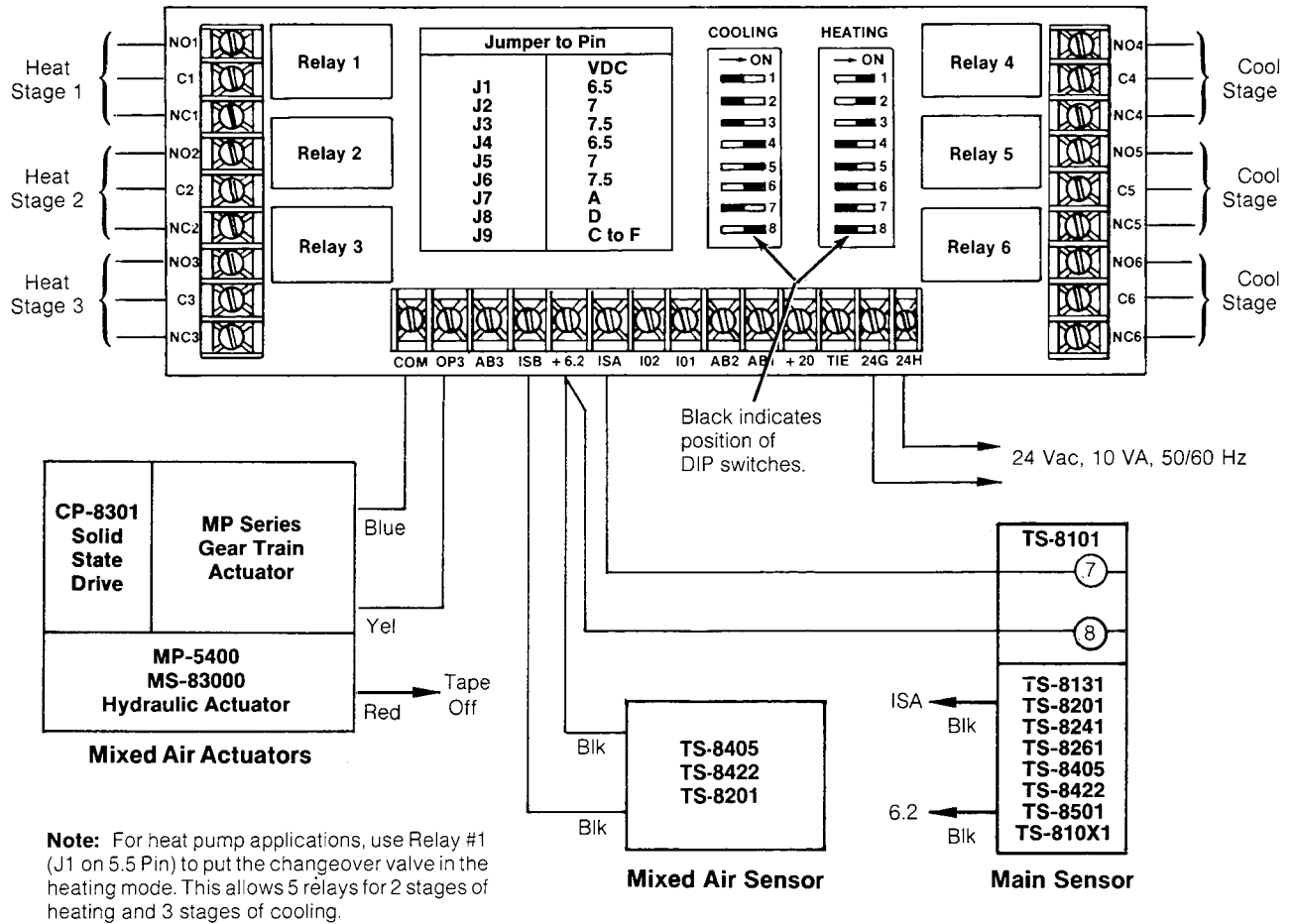

Figure-3

Pre- Installation

Visually inspect the package for damage. If damaged, notify the appropriate carrier. Visually inspect the device for obvious defects. Return damaged or defective products.

Mounting screws are not provided.

INSTALLATION

Mount the device in an inside location near the controlled equipment using the two slots in the track. Avoid locations where excessive vibration, moisture, corrosive fumes or vapors are present, or where high radio frequency or electromagnetic interference generating devices are near. NEMA Type 1 housings are intended for indoor use primarily to provide a degree of protection against contact with the enclosed equipment.

See Figure-2 for mounting dimensions.

WIRING

Make all connections according to job wiring diagrams and in compliance with national and local codes.

All circuits must be wired NEC Class 1 unless only one CP-8161 with all low voltage (under 30 Vac) connections is used in the enclosure.

Two separate No. 18 twisted pair wires (six turns per foot), low voltage are suitable for up to 1000 feet for the sensor leads.

When more than one programmable controller is used in the same enclosure, one Class 2 transformer with proper VA rating should be used to power all programmable controllers.

Never run line voltage in the same conduit with unshielded sensing element leads.

Shielded cable must be used when it is necessary to install the DC signal leads in the same conduit with power wiring, or when it is known that high RFI/EMI generating devices are near. Terminate the shield at the controller only on the COM (-) terminal.

Caution: Never connect the shielding or common to earth ground.

Refer to the wiring diagram (Figure-3) for typical connection to power, inputs and outputs required by the application.

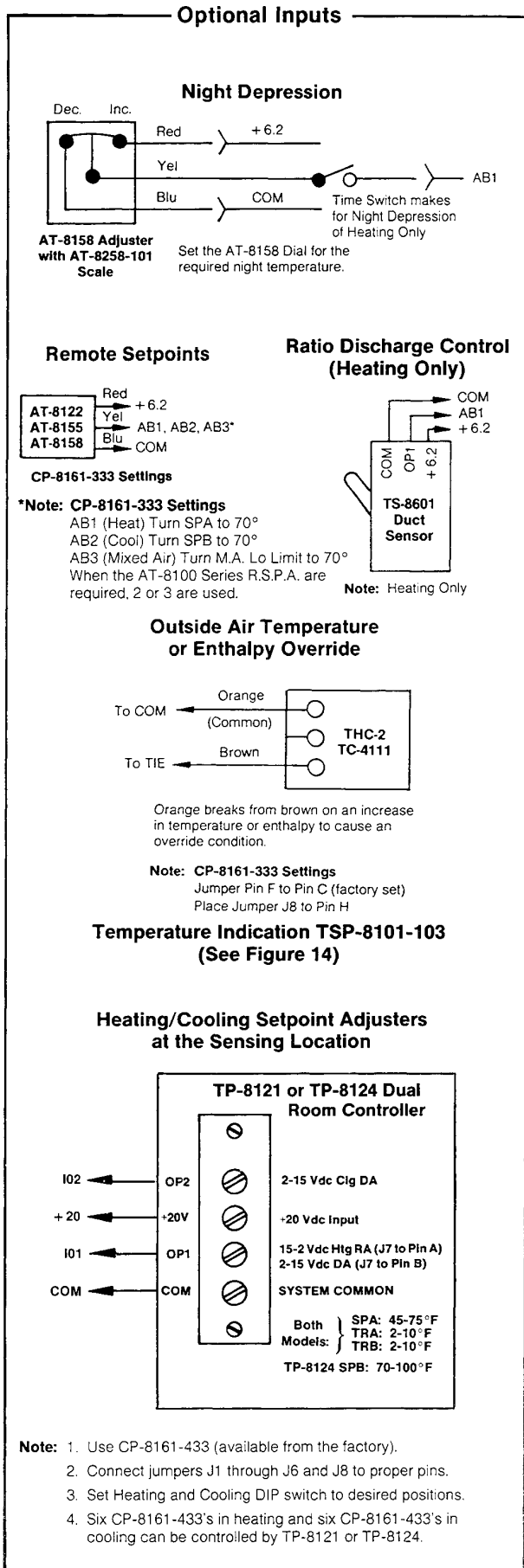

Figure-4

OPERATIONAL DATA

The general operational capability of the programmer is explained on page 12 in Theory of Operation.

Control Arrangements

The instructions are provided for three applications of staged control arrangements plus input and output options, as follows:

A staged 3 heat/3 cool/ mixed air application is shown in Figure-3. As an option, position 8 on the cooling DIP switch can be placed in the "off" position. This will provide a true mixed air controller, and the mixed air will be maintained at the temperature set on the mixed air low limit setpoint. Turn the mixed air start point adjustment full clockwise to disable.

A staged 3 heat/2 cool/fan cycle/mixed air application is shown in Figure-8.

A staged 2 heat/2 cool/humidification/dehumidification is shown in Figure-9.

Optional Inputs and Outputs

Figures-4 and 5 show the application of optional control inputs and outputs.

Optional Inputs

- Night depression (adjustable).
- Remote setpoints of heating, cooling and mixed air temperature.
- Ratio discharge control for heating.
- Outside air temperature or enthalpy override of the mixed air damper control to minimum ventilation when the outside air cannot cool.
- Separate heating and cooling setpoint adjusters at the sensing location.

Optional Outputs

- Heating
Hydronic valve control.
SCR electric heat control, single or 3 phase power.
- Cooling with chilled water valves.
- Mixed air damper control with additional actuators in parallel.
- Slaving up to 5 additional programmable controllers for parallel operation.
- Heating and cooling lockout.

Jumper/Pin Programming Functions

The programmable controller block diagram, sequence of operating voltage signals and jumper/pin programming instructions are shown in Figures-10 and 11. Jumper/pin programming provides the following functions:

Relay selection: The Vdc pins designated the pull-in voltage (via Jumpers 1-6) that is measured at terminals IO1, IO2 and COM.

Heating voltage signal ramp, i.e., reverse or direct-acting (J7 to Pin A or B).

Mixed air override to minimum ventilation by cooling stage 1 or 2 (J8 to Pin D or E) or by external outdoor air enthalpy or temperature (J8 to Pin H and black jumper on Pins F and C).

Optional Outputs

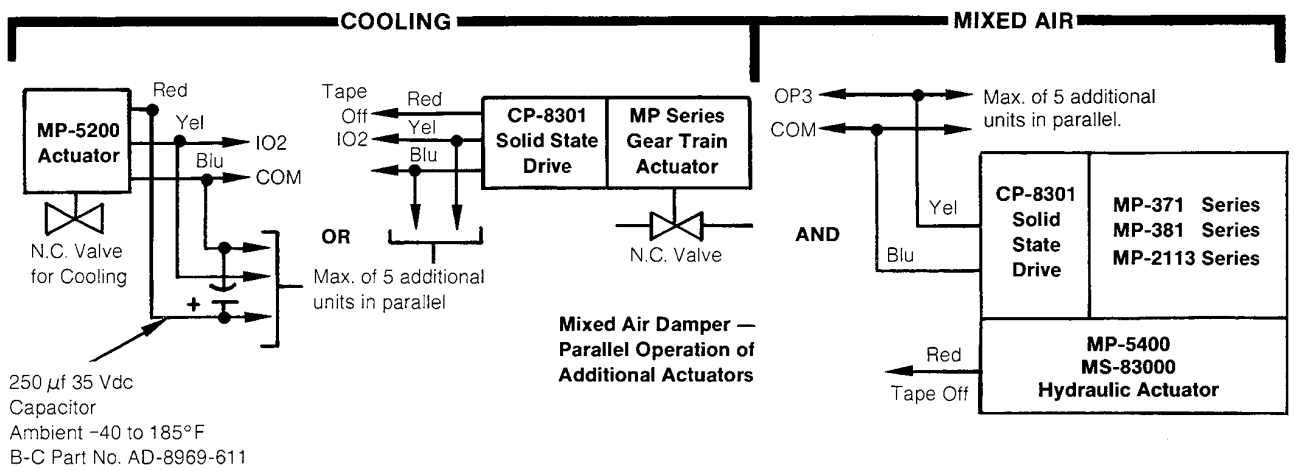
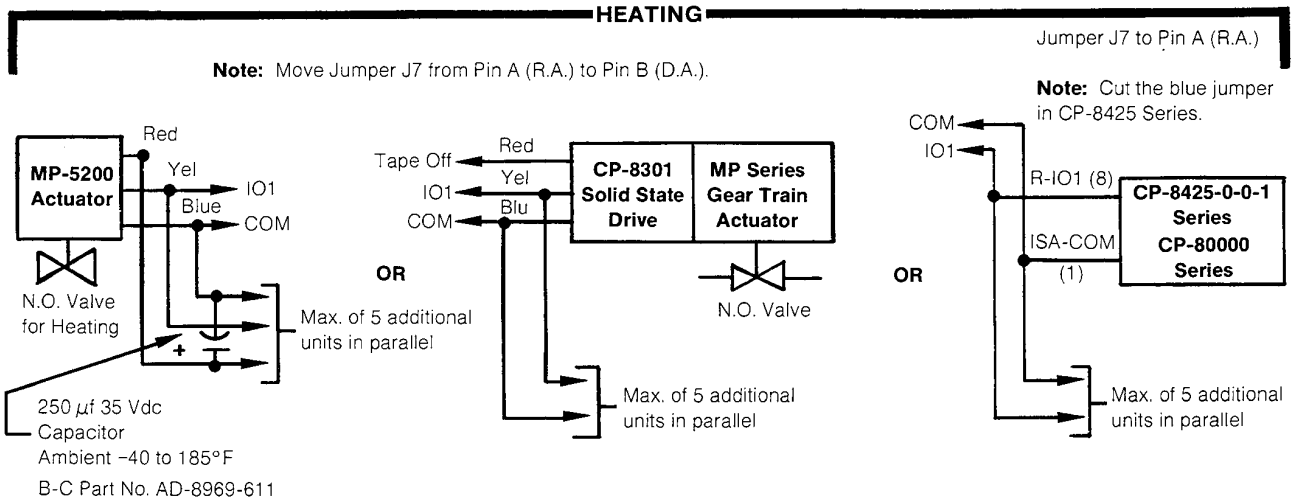

SLAVE

Maximum Number of Slave CP-8161-433 (5)

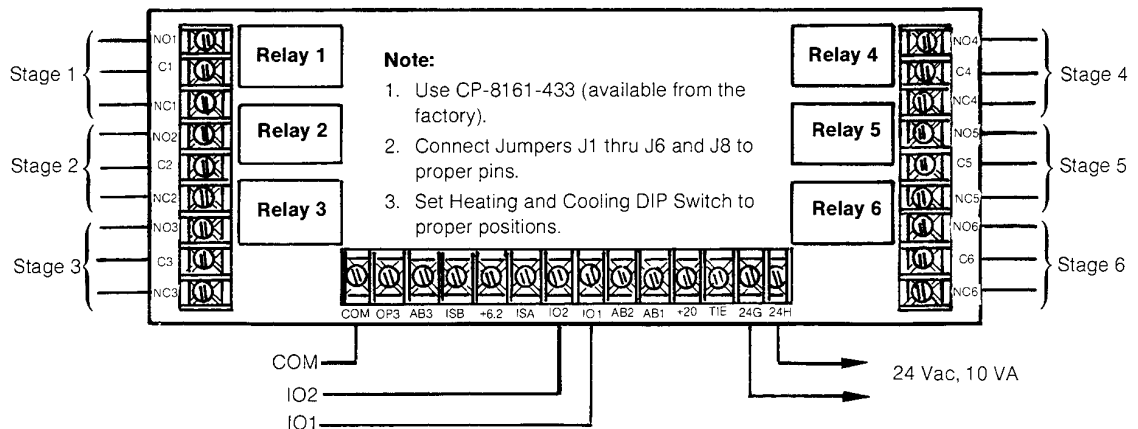

Note: Master-slave operation using up to 5 additional HVAC units with slave CP-8161-433's may be paralleled by the master CP-8161-333. Each slave CP-8161-433 has the same relay stage mixed air and output options as the master unit.

Figure-5

Heating and Cooling DIP Switches

The programming instructions for the heating and cooling DIP switches are shown in Figure-11. The DIP switches program the relays for heat, cool or fan operation and select the mixed air operating cycle.

Jumper/Pin and DIP Switch Programming

The jumper/pin and DIP switch programming makes it possible to provide:

An economizer mixed air cycle in conjunction with -

- Up to 6 stages of heat or cool.
- Any combination of heat and cool stages.
- Any combination of heat and cool stages plus a unit fan stage.
- Proportional output signals for control of heating valves, cooling valves and SCR electric heat control.

Multiple cycles, such as 2 heat and 2 cool stages with humidification and dehumidification stages.

A mixed air cycle with adjustable minimum ventilation which operates independently of the heating and cooling program. The mixed air temperature may be set in the range of 41 to 95°F by the mixed air low limit adjuster.

Deadband

The deadband between heating and cooling is the difference in the SPB and SPA settings. For example, the deadband is 13°F when SPB is set at 78°F and SPA is set at 65°F.

Mixed Air Start Point

The point at which the mixed air cycle starts to operate in the heat and cool program is adjustable by using the mixed air start point (MASP). Turn the MASP adjuster clockwise to increase the deadband between free cooling and operation of the cooling equipment.

The mixed air operating throttling range is the setting of TRB when controlled from the cooling ramp signal.

When the mixed air temperature is 5° above the mixed air low limit setting, the mixed air damper is positioned directly by the mixed air ramp signal. The mixed air low limit control has a 10°F fixed throttling range.

If the mixed air temperature approaches the low limit setting, the low limit proportions the outside air damper fully closed (or minimum ventilation position) 5°F below the setpoint, and allows full opening of the outside air damper 5°F above the setpoint.

The adjustment and programming locations are shown in Figure-13.

OPERATION

The CP-8161-333 is factory set to provide 3 stage heat/3 stage cool/mixed air cycle program. Refer to Figure-3.

When the space temperature drops below its heating setpoint (SPA typically 65°F), the controller provides up to 3 stages of heat (or will proportion an SCR electric heat control) to maintain the SPA setting. The mixed air is in the minimum damper position setting for ventilation.

When the space temperature approaches the cooling setpoint (SPB typically 78°), the mixed air dampers are proportioned to provide maximum cooling from the outside air. The dampers are proportioned to the minimum ventilation position if the mixed air temperature approaches the low limit setting.

When the outside air cannot provide enough cooling, the controller provides 3 cooling stages (or will proportion chilled water valves) to maintain the SPB setting.

The mixed air is returned to the minimum damper position when the first stage of cooling is energized. See programming instructions for other options. For applications requiring other combinations of heat and cool stages, simply select the staging relays by using the programming instructions for the heating/cooling DIP switches and jumpers.

Examples:

For a 4 stage heat/2 stage cooling application use factory settings but set switch 4 of the heating DIP to "on" and set switch 4 of the cooling DIP to "off". Relays #1-4 will then be heating relays. The throttling range of heating remains 3°F unless changed by adjusting TRA or TRB. Place Jumper J4 on Pin 8.

For a 6 stage cooling application, set switches 1 through 6 of the heating DIP to "off" and set switches 1 through 6 of the cooling DIP to "on". The throttling range remains 3°F unless changed by adjusting TRB. Place Jumper J4 on pin 8, J5 on Pin 8.5, and J6 on Pin 9. SPA can still be the setpoint for proportional heating.

For 6 stage heating application, set switches 1 through 6 of the heating DIP to "on" and set switches 1 through 6 of the cooling DIP to "off". The throttling range remains 3°F unless changed by adjusting the TRA. Place Jumper J4 on pin 8, J5 on Pin 8.5, and J6 on Pin 9. Set SPA at 65°F, for example. The cooling ramp has control of the mixed air. Cooling switch 8 must be on. To start to open the mixed air for cooling, set SPB at 70°F. When TRB is set at 5°F, the mixed air cycle will start at 65°F (at 0% Min.). The Mixed Air Cycle will start at a temperature of the SPB setting minus the TRB setting.

When an air supply fan stage is used (Figure 8), the fan is off in the program deadband. On a call for staged or proportional heating or cooling, the fan starts first. When the fan stage is used, the fan must always be running while electric heat or direct expansion cooling is energized.

For heat pump applications, Relay 1 controls the unit changeover valve. See the heat pump note in Figure-3.

For systems without a mixed air cycle, and with multiple cycle operation (Figure-9), the room temperature is maintained without a mixed air cycle. The relative humidity is typically maintained in the range of 40-55% Rh. Humidity control is maintained by relays 5 and 6 which are controlled by the mixed air controller section and humidity sensor.

Blank charts are provided inside the cover to record the application jumper/pin and DIP switch programs for reference in future service work.

HEATING, COOLING LOCKOUT

Lockout stages of heating or cooling are accomplished by braking the lead from the relay common terminal to the controlled device with a relay or switch. See Figure-6.

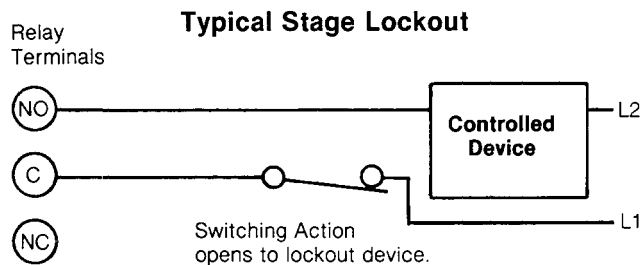

Figure-6

To lockout proportional heating or cooling valves, use a relay or switch. See Figure-7.

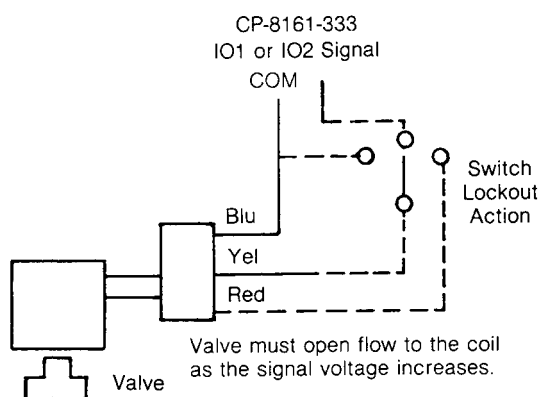

Figure-7

CHECKOUT PROCEDURE

(For tracing a controller malfunction)

Use a 20,000 ohm per volt VOM for test readings.

Step 1. Provide 24 Vac, 10 VA, 50/60 Hz supply power to terminals 24 and 24G

Step 2. Verify the voltage at terminals +20 to COM and +6.2 to COM. If these voltages are not present, replace CP-8161-333.

Step 3. Verify the sensors. Test the sensor leads to terminals ISA to +6.2 and ISB to +6.2 for approximately 1000 ohms resistance. Replace defective sensors or correct the wiring.

Step 4. Verify voltage outputs 15 to 2 Vdc at terminal IO1 and COM, and 2 to 15 Vdc at terminals IO2 and COM. Verify 5 to 12 Vdc at terminals OP3 to COM. If these voltages are not present, replace CP-8161-333.

Step 5. Verify the relay contact action. The common relay contact (C) must be made to the normally open contact (NO) when the coil is energized (red light on). Replace CP-8161-333 if the relays are defective.

Step 6. Verify the jumper/pin positions and DIP switch settings (Figure 11) for the required CP-8161-333 program. Reposition the jumpers or DIP switch settings. If they are defective, replace CP-8161-333.

Step 7. Adjust the mixed air cycle start point.

Step 8. Verify the calibration using the calibration procedure. Place the CP-8161-333 (or see Field Repair, Page 15) if calibration cannot be made.

Step 9. Verify the minimum ventilation position setting. The position is adjustable from 0 to 100%.

CALIBRATION

Use a 20,000 ohm per volt VOM.

Step 1. Remove the sensor lead connections from terminals ISA to 6.2 and replace with a 1000 ohm $\pm 1\%$ resistor (Tool-203).

Step 2. Turn SPA until the voltage at terminals IO1 to COM is 6 Vdc. Hold the SPA knob in position and rotate the metal indicator counterclockwise until over 70°F on the dial scale.

Step 3. Turn SPB until the voltage at terminal IO2 to COM is 6 Vdc. Hold the SPB knob in position and rotate the metal indicator counterclockwise until over 70°F on the dial scale.

Step 4. The controller is calibrated. Remove the 1000 ohm test resistor and reconnect the sensor leads.

Switch Action	Controlled Device	Controlled Device Action
Yel to Blue	CP-8301	CCW Rotation
Yel to Red	CP-8301	CW Rotation
Yel to Blue	MP-5200 Series	Retracts
Yel to Red	MP-5200 Series	Extends

CP-8161-333
3-Heat/2-Cool/Fan Cycle/Mixed Air

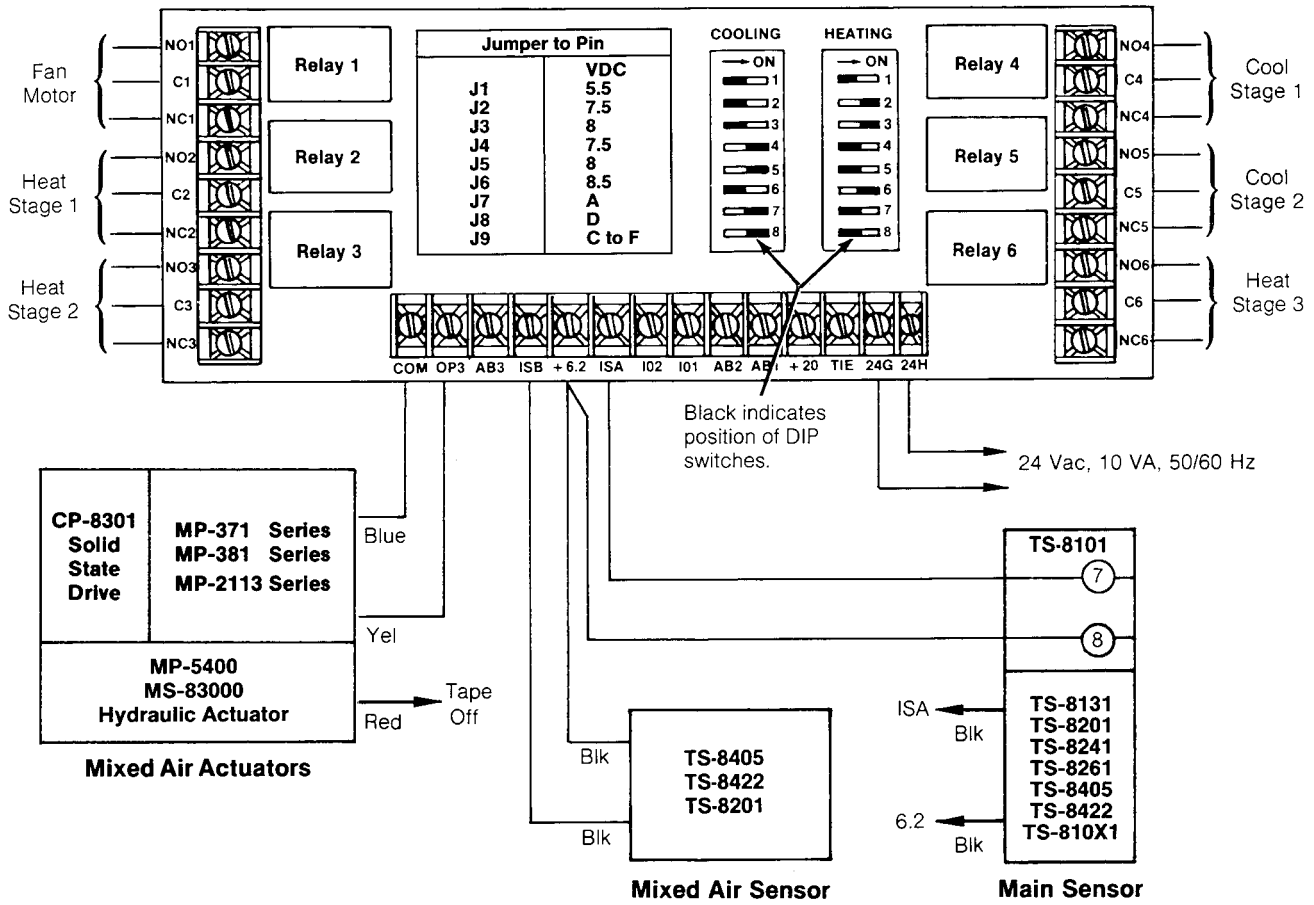

Figure-8

CP-8161-333
2-Heat/2-Cool/Humidification/Dehumidification

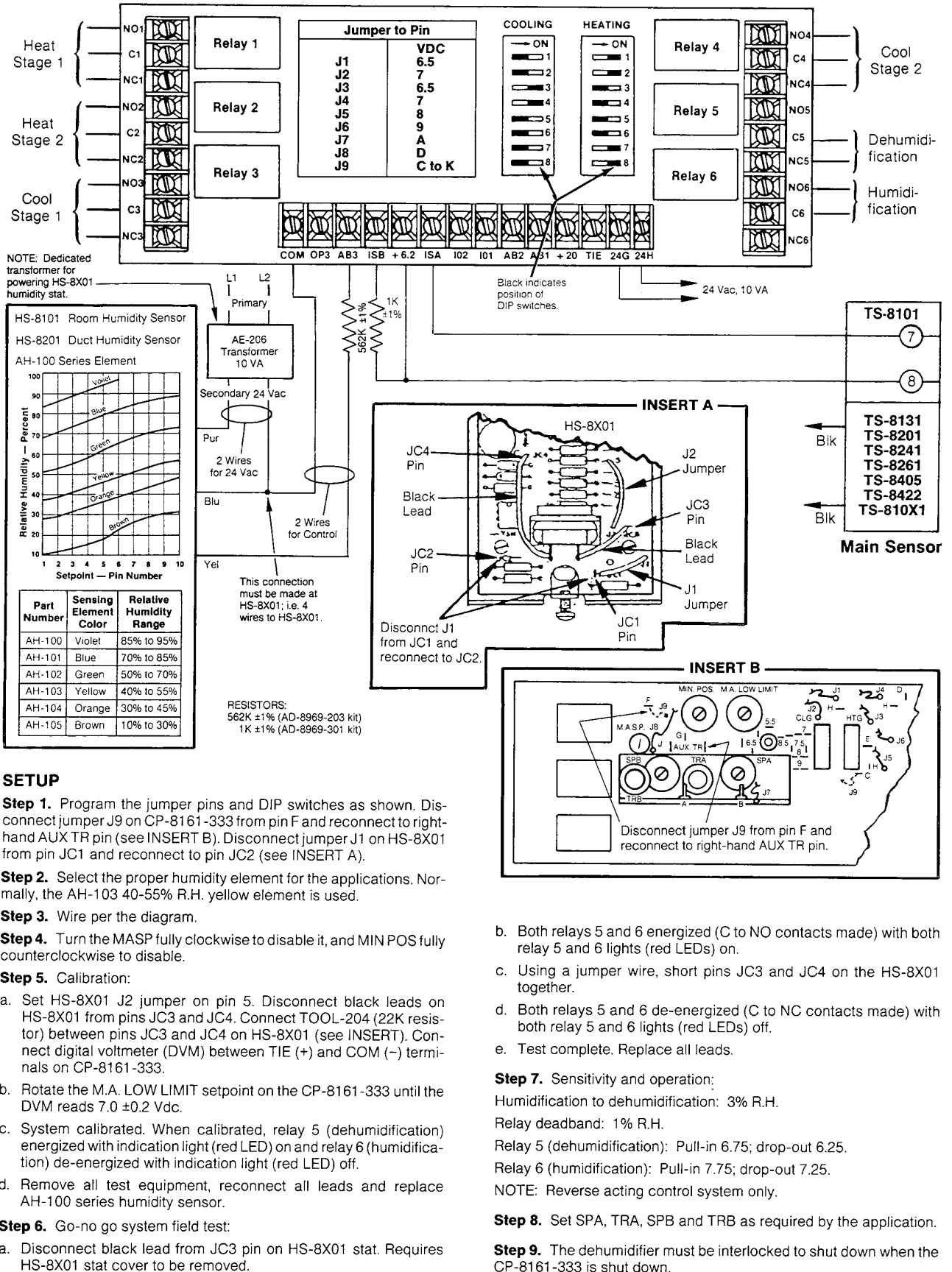
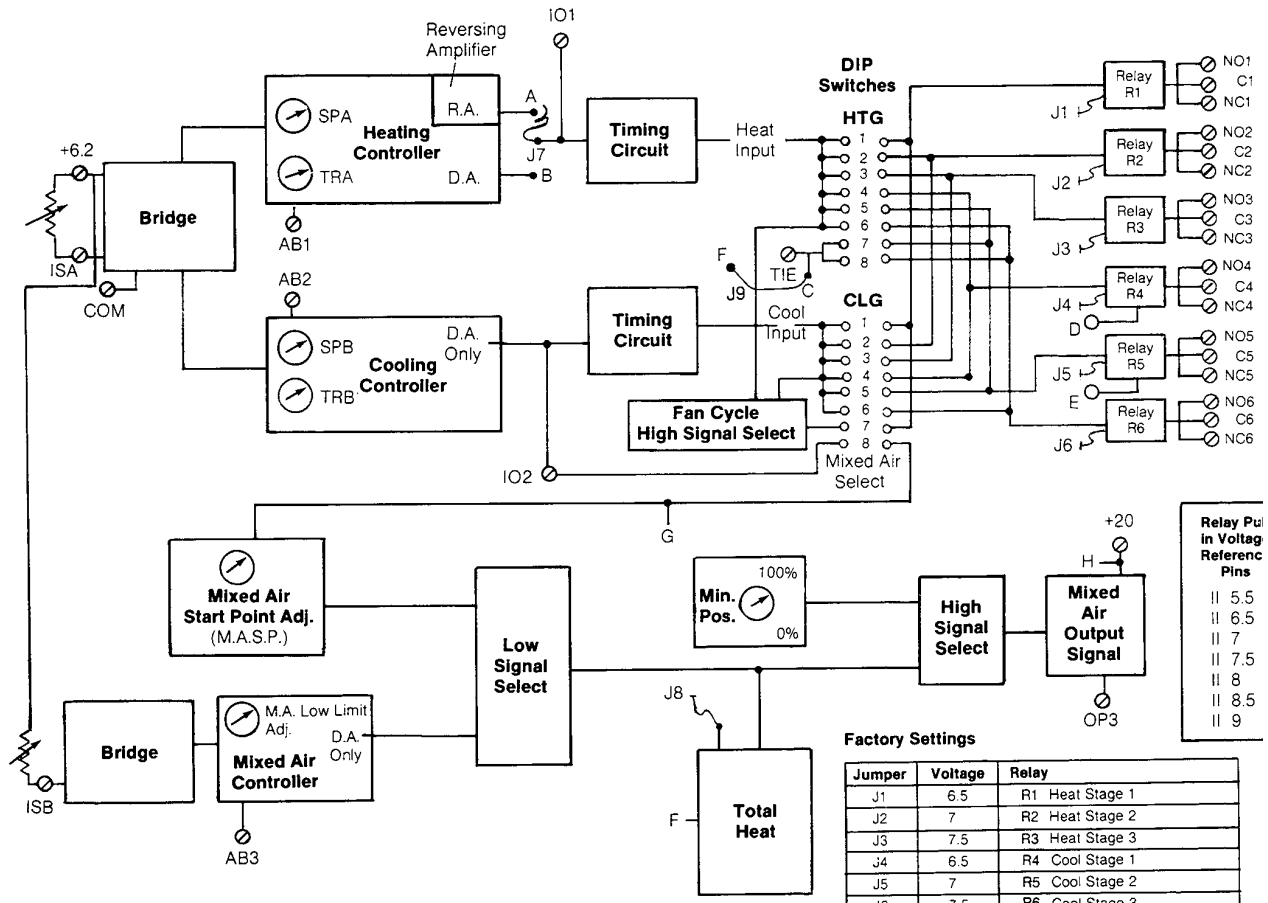
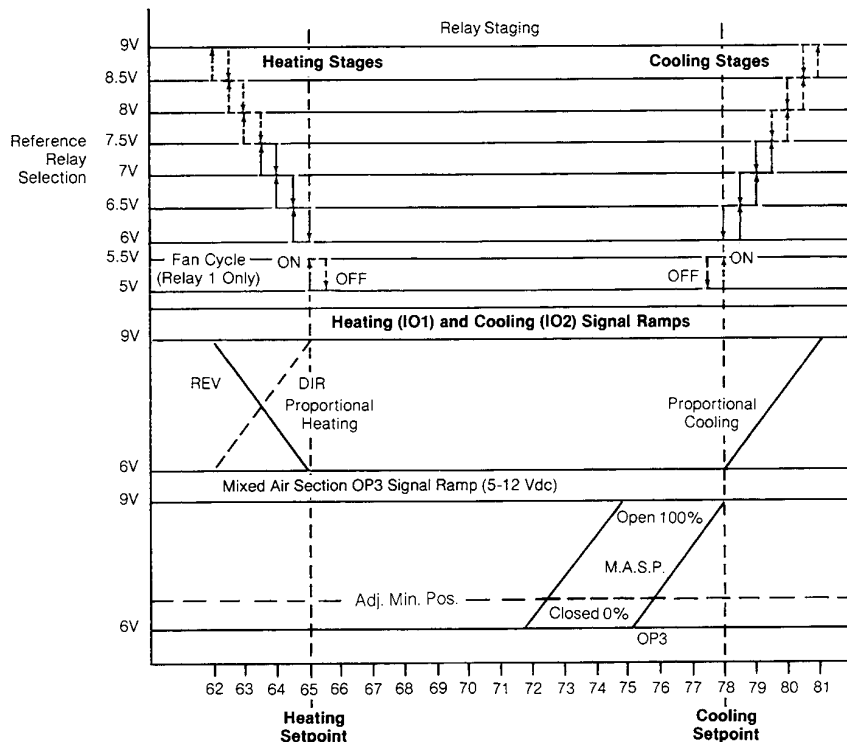

Figure-9



Controller Block Diagram



CP-8161-333 Programmable Controller Sequence of Operation

Figure-10

Jumper	Function		Pin	Function
J1	Relay 1 Operate Reference	T O	5.5 Vdc	Operate Reference for R1–R6 (Selection of J1–J6) Selects Relay Pull-in Voltage Measured at IO1 (Heat) and IO2 (Cool)
J2	Relay 2 Operate Reference		6.5 Vdc	
J3	Relay 3 Operate Reference		7 Vdc	
J4	Relay 4 Operate Reference		7.5 Vdc	
J5	Relay 5 Operate Reference		8 Vdc	
J6	Relay 6 Operate Reference		8.5 Vdc	
J7	HTG Output Select	T O	A	HTG (R.A.) at IO1
			B	HTG (D.A.) at IO1
J8	Mixed Air Override		D	Stage 4 (Cooling 1)
			E	Stage 5 (Cooling 2)
J9		H	Enthalpy/Temperature	
Pin C	TIE Terminal (HTG Switch Position 7 and 8 Off)		F to C	Enthalpy/Temp.
			Pin F	Enthalpy/Temperature Override (J8 to Pin H)

Note: Jumpers J1–J6 must **always** be placed on pins 6.5 through 9 Vdc (even when not used).
Pin "C" is jumpered to pin "F" at factory.

Programming Instructions — HTG/CLG DIP Switches

HTG DIP Switch		CLG DIP Switch	
Position	Function	Position	Function
1 On	Relay 1 to HTG	1 On	Relay 1 to CLG
2 On	Relay 2 to HTG	2 On	Relay 2 to CLG
3 On	Relay 3 to HTG	3 On	Relay 3 to CLG
4 On	Relay 4 to HTG	4 On	Relay 4 to CLG
5 On	Relay 5 to HTG	5 On	Relay 5 to CLG
6 On	Relay 6 to HTG	6 On	Relay 6 to CLG
7 On	Relay 5 to TIE	7 On	Relay 1 to Fan
8 On	Relay 6 to TIE	8 On	Mixed Air to CLG Ramp

Factory Setting	
Heating Switch	Cooling Switch
1 On	1 Off
2 On	2 Off
3 On	3 Off
4 Off	4 On
5 Off	5 On
6 Off	6 On
7 Off	7 Off
8 Off	8 On

Note: Refer to Figures 10 and 13 for further detail. DO NOT place both HTG and CLG DIP switches in the ON position.

Figure-11

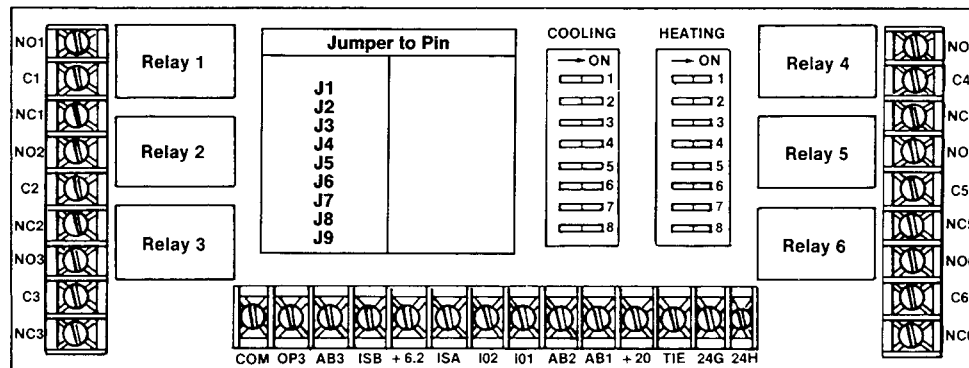

Figure-12

Note: Programming aid for selection of jumper/pin locations and DIP switch settings for application programs are not shown in these general instructions. Mark the jumper/pin locations and DIP switch settings in the boxes above and inside the CP-8161-333 cover.

THEORY OF OPERATION

The CP-8161-333 Programmable Controller can be operationally described by dividing the controller into basic functional blocks. Refer to the controller block diagram (Figure 10).

Zone Thermostats (TS-8000 Series) The zone thermostat employs a 1000 ohm 21°C (70°F) resistance type (Balco wire) temperature sensor. Any non-adjustable TS-8000 Series sensor can be used. This sensor increases in resistance with an increase in temperature (3.96 ohms per °C or 2.2 ohms per °F). This change is detected by the heating controller and cooling controller in the CP-8161-333.

Heating Controller Section The heating controller input accepts the zone thermostat resistance signal. The input converts this resistance signal change into a DC millivolt signal change. The DC millivolt signal is then amplified, producing a 2 to 15 Vdc output at terminals IO1 and COM. Selection for direct-acting or reverse-acting operation is made by positioning Jumper J7 to Pin A (reverse-acting) or B (direct-acting). The heating controller output signal is used internally to operate the heating relays or to position an external proportional heating controlled device. Adjustments are available for setpoint 7.22 to 23.9°C (45 to 75°F) and system throttling range 1.1 to 5.5°C (2 to 10°F).

Cooling Controller System The cooling controller input also accepts the zone thermostat resistance signal. The input converts this resistance signal change into a DC millivolt signal change. This DC millivolt signal is then amplified, producing a 2 to 15 Vdc output at terminals IO2 and COM. This output is used to operate the cooling relays as well as sequence the mixed air dampers if the cooling DIP switch position 8 is “on”. This output is also available to operate external proportional cooling controlled devices. Adjustments are available for setpoint 21 to 37.8°C (70 to 100°F) and system throttling range 1.1 to 5.5°C (2 to 10°F).

Mixed Air Thermostat (TS-8000 Series) The mixed air thermostat functions identically to the zone thermostat described above. The resistance change of the mixed air thermostat is detected by the mixed air controller section of the programmable controller.

Mixed Air Controller Section The output at OP3 is factory set to follow the zone cooling controller ramp (by having cooling DIP switch #8 “on”) to provide a 6 to 9 Vdc signal to the mixed air damper actuator as the zone cooling controller output changes from 3 to 16 Vdc.

Table-3 Mixed Air Controller Auxiliary Throttling Range.

For Total T.R. °F of:	Add between Aux. T.R. ^a Pins a Resistor of Value:
11	10 MEG
12	5.1 MEG
13	3.3 MEG
14	2.4 MEG
15	2 MEG
16	1.6 MEG
17	1.5 MEG
18	1.2 MEG
19	1.1 MEG
20	1 MEG

^a No additional pin or jumper setting required.

The mixed air controller accepts the mixed air sensor resistance signal and will override the zone cooling ramp to provide a proportional mixed air low limit.

The mixed air controller has a fixed throttling range of 5.5°C (10°F). Auxiliary pins are provided for other throttling range selections. The mixed air controller setpoint 41 to 95°F (5 to 35°C) establishes a minimum mixed air temperature control point. When the mixed air low limit is reached, the mixed air actuator is proportionally controlled in order to maintain this low limit temperature.

As an option, position 8 on the cooling DIP switch can be placed in the “off” position. This will provide a true mixed air controller and the mixed air will be maintained at the temperature set on the mixed air low limit setpoint. Turn the M.A.S.P. full clockwise to disable it.

The operating position, with respect to the cooling control outputs, is adjustable by setting the mixed air start point potentiometer.

Mixed Air Override An option that provides a method of limiting the volume of outside air taken in when the outside air is unacceptable for free cooling. The input signal is derived from either:

Outside enthalpy or temperature override thermostats: When Pin F is jumpered to Pin C, the override condition is created by an open circuit between COM and TIE; override is prevented by a closed circuit between COM and TIE, or

Signal from stage 1 cooling (J8 jumper connected to Pin D) and no connections to TIE, or

Signal from stage 2 cooling (J8 jumper connected to pin E) and no connections to TIE.

Minimum Position Section The minimum position section establishes the minimum DC voltage level to which the output of the mixed air controller is allowed to fall. This DC voltage output between OP3 and COM provides the operating signal for the mixed air actuator.

Heating/Cooling Sections The six relays incorporated in the CP-8161-333 Programmable Controller can be programmed to operate in either the heating or cooling mode. These relays are programmed by positioning the heating and cooling DIP switches in the “on” position. **Note:** Heating and cooling DIP switches cannot both be in the “on” position; The operating reference for the pull-in voltage of the relays can be programmed by placing the respective J1 through J6 jumper on the proper operate reference pin. As the voltage from the heating or cooling controller increases through the respective heating or cooling selector DIP switch, the relays will operate when the voltage matches the operate reference selected. There is an interstage time delay on unit start-up.

As an option, relay 1 can be programmed to operate from both the heating and cooling controller for fan operation in the unoccupied mode.

LEDs (light emitting diodes) are provided for each relay stage to indicate the operating status. These LEDs will be “on” when the relay is energized.

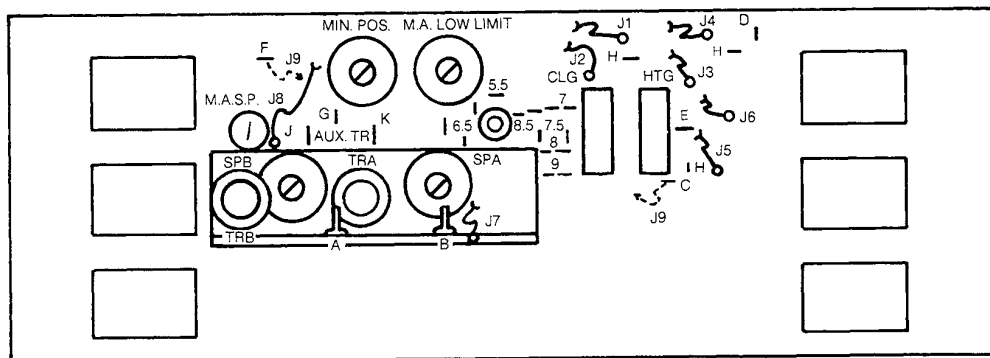
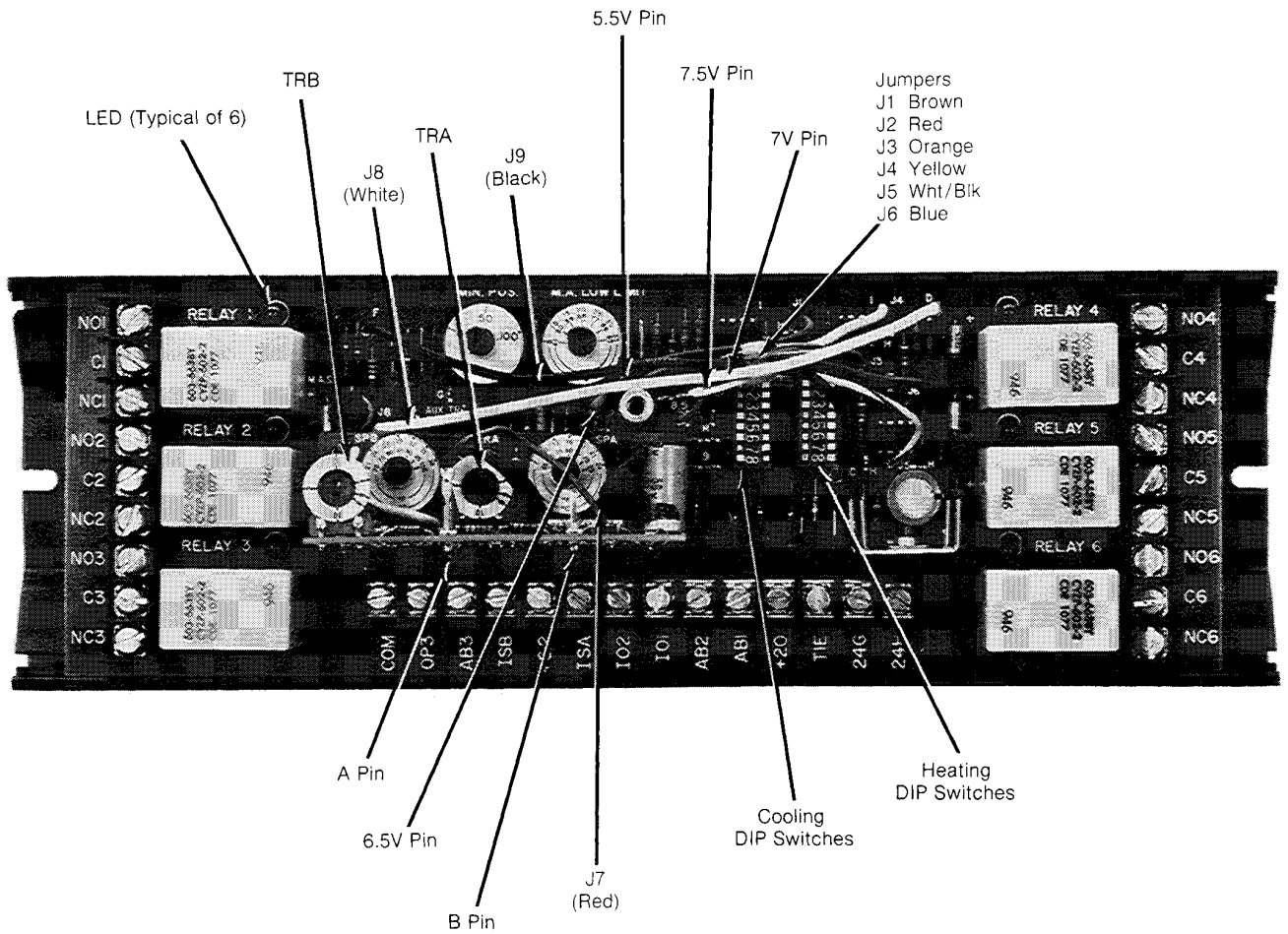

Figure-13 Pin and Jumper Location.

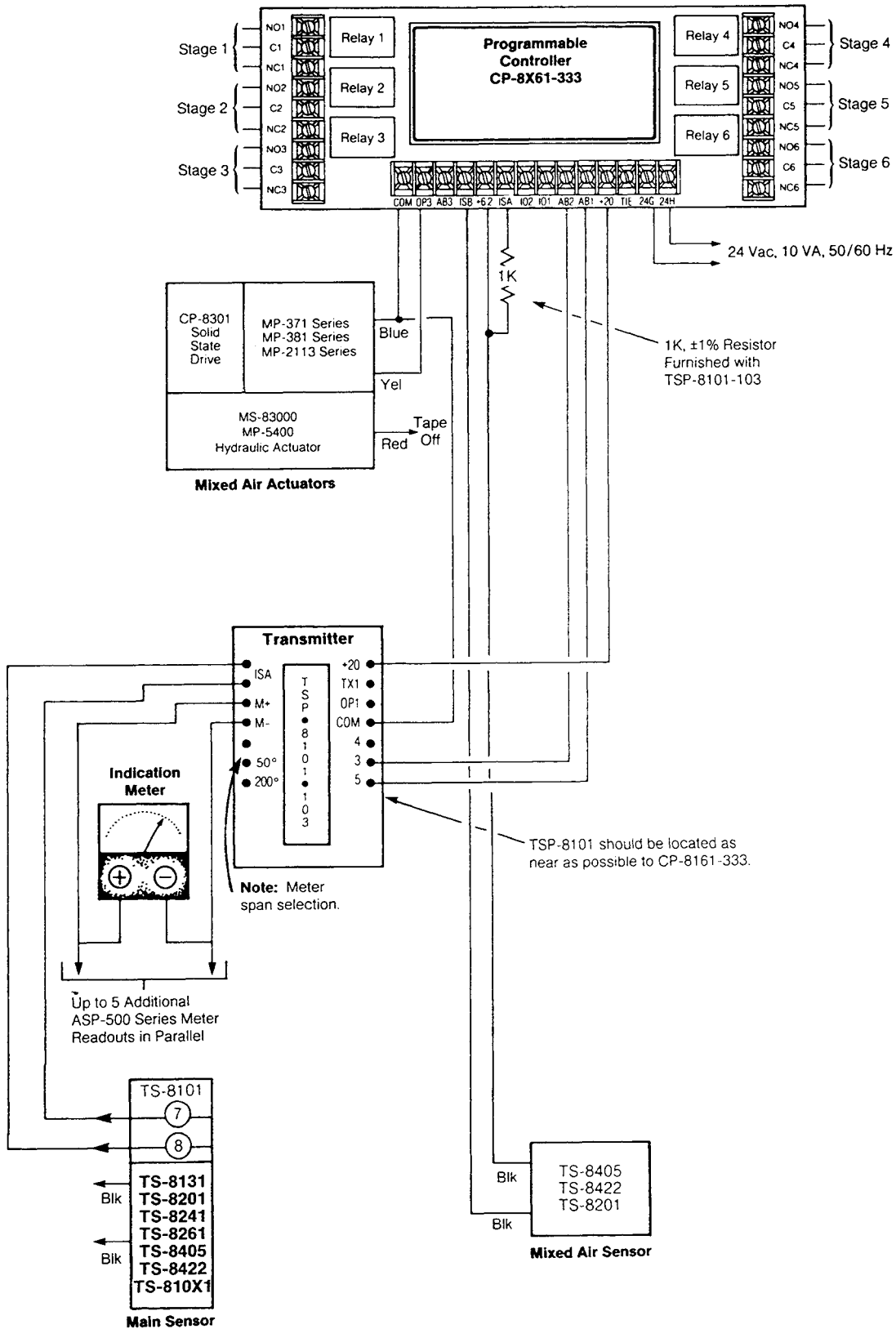

Figure-14 TSP-8101-103 Temperature Transmitter for Temperature Control Plus Temperature Indication Used with CP-8X61-333 Programmable Controller.

MAINTENANCE

Regular maintenance of the total system is recommended to assure sustained optimum performance.

FIELD REPAIR

Replace the plug-in circuit board containing the Heating and Cooling Controllers (BDZD-961-1) with their respective setpoint and throttling range adjusters (see Figure-13):

1. Remove 24 Vac power to CP-8161-333.
2. Pull circuit board straight out of the CP-8161-333.
3. Replace circuit board with functioning unit (BDZD-961-1).
4. Restore 24 Vac power to CP-8161-333.
5. Verify the calibration using the calibration procedure shown on page 8.

Caution: Plug-in board (BDZD-961-1) cannot be used in TP-8124/TP-8125 dual room controllers.

Copyright 2008, TAC
All brand names, trademarks and registered
trademarks are the property of their respective
owners. Information contained within this
document is subject to change without notice.

F-18096-9

TAC
1354 Clifford Avenue
P.O. Box 2940
Loves Park, IL 61132-2940
www.tac.com

t.a.c. [®]
by **Schneider Electric**