



Internal Use Only

<http://biz.lgservice.com>

Window Air Conditioner

SVC MANUAL

MODEL : LP090CED-Y8

CAUTION

Before Servicing the unit, read the safety precautions in General SVC manual.
Only for authorized service personnel.

1. Specification

Model		LP090CED-Y8		
Cooling Capacity	kW	2.58	2.64	
	Btu/h.	8,800	9,000	
Heating Capacity (for Heat Pump models)	kW	-	-	
	Btu/h.	-	-	
Electric Heater capacity	kW	3.3	3.5	
	Btu/h.	11200	11900	
Power Input	Cooling/Heating	W	750	
Running Current	Cooling/Heating	A	3.8	
Starting current	Cooling/Heating	A	-	
Electric Heater Current		A	20	
EER	W/W	3.44	3.43	
	Btu/h.W	11.7	11.7	
COP	W/W	-	-	
Power Supply	Ø / V / Hz	1 / 208 / 60	1 / 230 / 60	
Power Factor	%	94.9	95.7	
Air Flow Rate	Indoor,Max	m ³ /min(CFM)	9.5(335)	
	Outdoor,Max	m ³ /min(CFM)	20(706)	
Moisture Removal		l/h	1.2	
Sound Level (Sound Pressure,1m)	Indoor,H/M/L	dB(A)±3	45/-/43	
	Outdoor,Max	dB(A)±3	60/58	
Refrigerant & Charge		g(oz)	R22, 870(30.7)	
Compressor	Type		Rotary(Non Tropical)	
	Model		QA114KCB	
	Motor Type		PSC	
	Oil Type		SUNISO 4GSI	
	Oil Charge	cc		290
	O.L.P Name			MRA 12017-12026
Fan	Type(In/Out)		Cross Flow Fan	
	Motor Type(In/Out)		4 Poles	
	Motor Output(In/Out)	W	18.4/60	
Power Supply Cable (Power Cord)		No.*mm ²	3 * 2.1	
Dimensions (W * H * D)		mm	1,066*400*505	
		inch	42*16*19-7/8	
Net Weight		kg(lbs)	42(92.4)	
Tool Code(Chassis)			YA	
Features	Temperature Control		Thermistor	
	Energy Saver Mode		O	
	Prefilter(washable/anti-fungus)		O	
	Plasma Filter		-2/	
	Steps, Fan/Cool/Heat		2/2	
	Airflow Direction Control(up&down)		Manual	
	Airflow Direction Control(left&right)		-	
	Remote Controller Type		Wall Thermostat	
	Setting Temperature Range	Cooling		54°F ~ 86°F(12.2°C ~ 30°C)
		Heating		54°F ~ 86°F(12.2°C ~ 30°C)
	Auto Operation (Micom Control)			-
	Panel Touch Type			Micom
	Timer			12h, On/Off
	Air Discharge			Rear
	Air-Ventilation			O
	Defrost Control			O
	Hot Start			-
	Look			L - Look
	Cabinet Type(Chassis Type)			Slide In-Out
Special Function			Electric Heater	

Note:

O : Applied, - : No relation

* For circuit breaker rating, please confirm to local standards wherever necessary.

* Some of functions are slightly different depending upon models.

* The specification may be subject to change without prior notice for purpose of improvement.

1.2 FEATURES AND BENEFITS

The PTAC has many features, some of which are different than those found on conventional PTAC units. The servicer must be familiar with these features in order to properly service the unit.

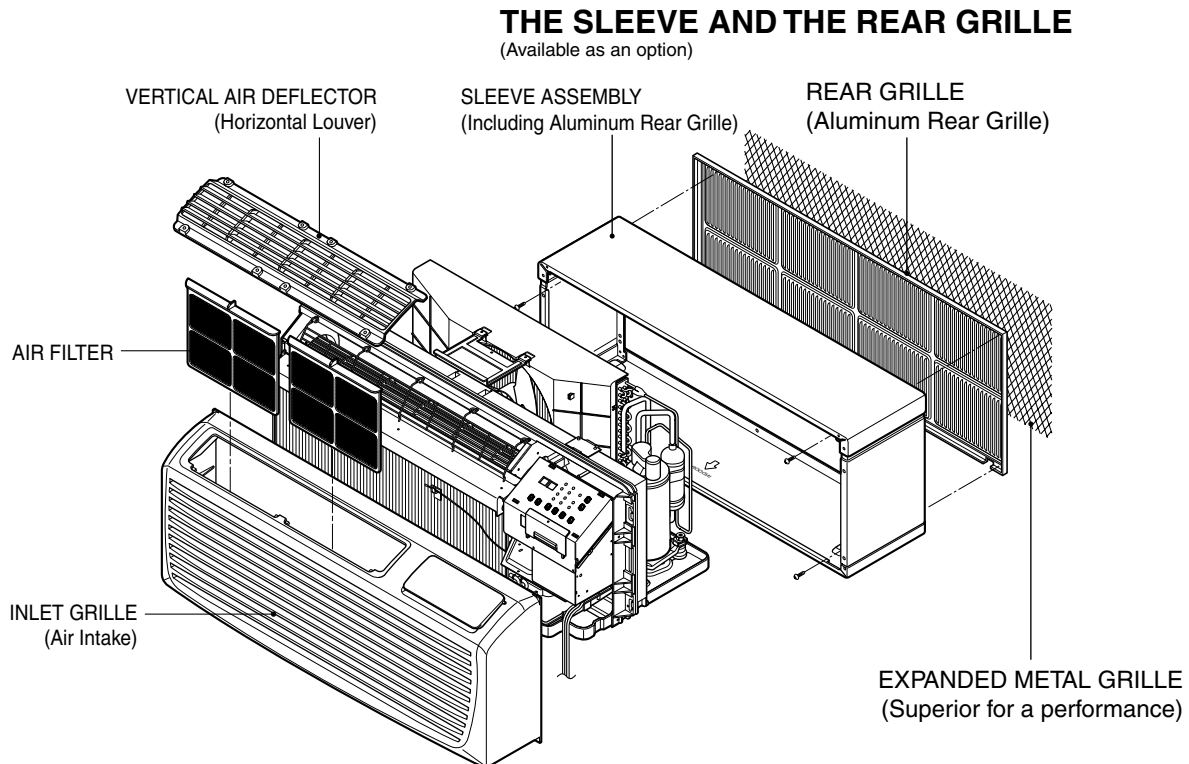

- **IIR (Infinite Impulse Response)**
The IIR function senses the temperature several times per second and makes micro-adjustments several times per second.
- **Compressor Restart Delay**
This feature extends the overall life of compressor by preventing the short-cycling of the air-conditioner. When the compressor restarts, LG PTAC is designed to give a minimum of three minutes to have a time of equalizing the refrigerant pressures for optimizing cycling.
- **Fan-Only Setting - High/Low**
The fan can run at HIGH or LOW speed without COOLING or HEATING to provide air circulation and ventilation.
- **Indoor Fan Speed Selections - High/Low**
The fan can run at HIGH or LOW speed for either COOLING or HEATING.
- **Two Fan motors**
The unit has two fan motors to provide quiet operation and maximum efficiency.
- **LED Diagnostics**
All units have this feature indicating the problem when the unit is not operating properly with easy-to-read diagnostics. For example, 1 blink every 2 seconds indicates compressor failure.

- **Indoor Filters**

The unit uses two indoor filters which slide in and cut easily. The filters may be cleaned by washing and brushing without removing the front grille.

- **Rotary Compressor**

The unit uses a rotary compressor for quiet, reliable operation and long life.

- **2 Position Discharge Grille**

The discharge grille can provide air flows upward at an angle of 40 off vertical or 15 degree off vertical. The angle is changed by removing the front grille and 4 screws that fasten the discharge grille to the front grille and rotating the louvers to an alternate position.

- **Indoor Room Freeze Protection**

When the unit senses the room temperature falls to less than 40° F the unit activates the fan motor and either the electric resistance heater or the hydronic heater to prevent pipes or fixtures from freezing. This also overrides front desk control of the unit mounted or wall mounted controls.

- **Door Switch/Occupancy Sensor**

The unit is capable of accommodating a field installed door switch and occupancy sensor to operate the energy management feature. For additional information, refer to the unit operation section.

- **Compressor Overload Protection**

This feature prevents the damage of the compressor by sensing the indoor tube temperature in heating. If the indoor temperature is over 130° F, the outdoor fan will be switched off and back on when the temperature drops below 120° F.

- **Outdoor Air Temperature Switchover**

This will effectively change the unit from heat pump mode to total electric resistance heat.

- **Temperature limits**

The unit is programmed to provide both heating and cooling temperature limits by dip switches on control panel from 50° F to 90° F. Temperature limits help to prevent overheating and overcooling and reduce energy costs.

- **Condensate Drain Valve**

The unit has a condensate drain valve to prevent water from collecting or freezing in the basepan.

- **Quick Heater Recovery**

The unit is designed to operate the electric heater to warm the room to the temperature set point as soon as heat pump cycle is on in heating. This feature has an advantage of reducing the time to reach the set point and improving the temperature increase for better comfort.

- **Reverse Cycle Defrosting - (PTHDs only)**

The unit will activate the reverse cycle defrost when the outdoor coil temperature has remained at a cold temperature to form the ice on the coil. This ice will reduce airflow through the coil and will also reduce the efficiency of unit. The LG PTHP will employ an active reverse cycle defrost function to melt the ice off the outdoor coil for insuring room comfort conditions and savings from extended operation.

- **High Temperature Heat Pump Operation Protection**

The compressor will be switched off to prevent damage when the heat pump is operated in high outdoor temperatures.

- **Remote Thermostat Control**

Each unit is built to be operated from any standard 4 or 5 wire remote-mounted thermostat, if desired. The unit has a built-in low voltage power source which can accommodate a large variety of thermostat choices-manual, auto changeover, or programmable. A remote thermostat can also be added to any installed unit.

- **Zone Sensor**

Occupants enjoy ultimate comfort with consistent climate control. Attach an optional, inexpensive remote Zone Sensor to exactly match the functions of the PTAC without disabling any features.

1.3 ELECTRONIC CONTROL

The controls will look like one of the following.

FAN SPEED

- Every time you push this button, it cycles through the settings as follows:
{High(F2) → Low(F1) → High(F2) → Low(F1)}

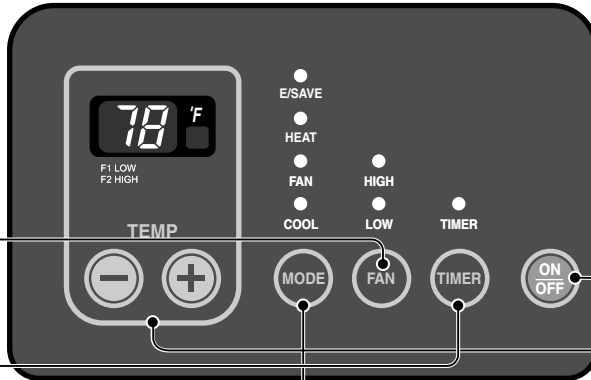

POWER

- To turn the air conditioner ON, push this button. To turn the air conditioner OFF, push the button again.
- This button takes priority over any other button.

MODE

- Push this button to cycle through the modes from COOL → FAN → HEAT → COOL.
- COOL
 - Fan runs continually for normal cooling operation.
- ENERGY SAVER
 - The fan stops when the compressor stops cooling. Approximately every 3 minutes the fan will turn on and the unit will check the room air temperature to determine if cooling is needed.
- FAN
 - Fan operation without heating or cooling.
- HEAT
 - Fan runs continually for normal heating operation.

TEMPERATURE SETTING

- Use this button to automatically control the temperature of the room. The temperature can be set within a range of 54° F to 86° F by increments of 2° F.
- The setting appears in the display.

TIMER

- SHUT-OFF TIME
 - You will usually use shut-off time while you sleep.
 - If unit is running, use Timer to set number of hours until shut-off.
 - For your sleeping comfort, once Time is set, the Temperature setting will raise 2° F after 30 minutes, and once again after another 30 minutes.
 - Push Timer to cycle through the settings from 1 Hour → 2 Hours → ... → 12 Hours maximum.

• VENTILATION

The ventilation lever is located to the lower left side of the unit. The ventilation lever must be in the CLOSE position in order to maintain the best cooling conditions.

When fresh air is necessary in the room, set the ventilation lever to the OPEN position.

The damper is opened and outdoor air is drawn into the room. This will reduce the cooling or heating efficiency.

CAUTION

When the air conditioner has performed a cooling or heating operation and is turned off or set to the fan mode, wait at least 3 minutes before resetting to the cooling operation.

NOTE

A slight heat odor may come from the unit when first switching to HEAT after the cooling season is over. This odor, caused by fine dust particles on the heater, will disappear quickly. This is harmless.

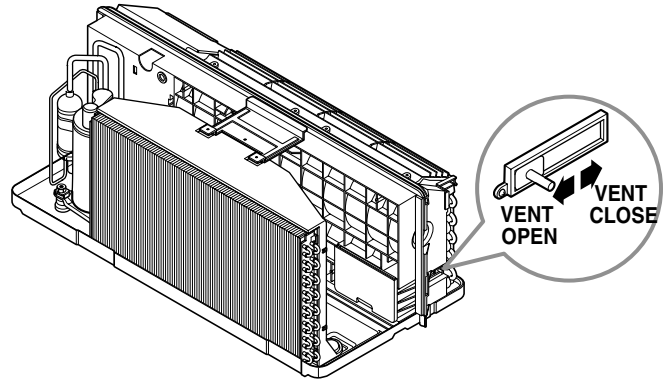

1.4 ADDITIONAL CONTROLS

• REMOVING THE FRONT GRILLE

Additional controls are available after removing the front grille and option cover of control box.

To remove the front grille, pull out the bottom of front grille and then lift up.

To replace the front grille, place the tabs over the top of the unit and push the bottom of front grille until the clips snap into place.

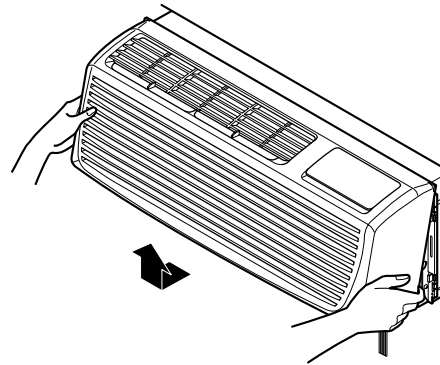

• ADDITIONAL CONTROLS

The additional controls are located behind the option cover of control box. The standard settings will be in the OFF position. The authorized servicer has to check switches and ensure the switches are in the desired position.

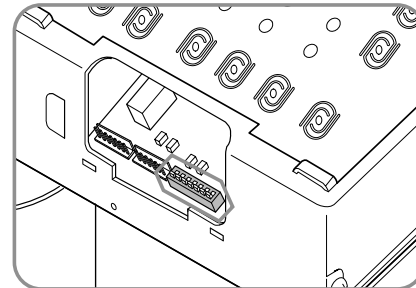
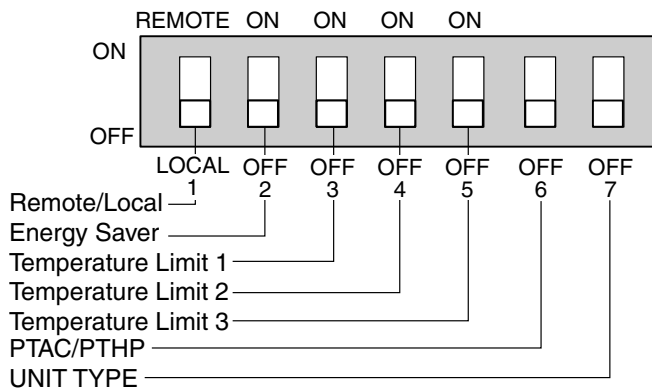

• TEMPERATURE LIMITING

Temperature Limiting can save money by limiting the lowest temperature for cooling and the highest temperature for heating. The temperature limiting is controlled by switches #1 - #3.

This temperature limiting is not available with the Remote Wall Thermostat.

Temperature Limit #1	Temperature Limit #2	Temperature Limit #3	Cooling Operation		Heating Operation	
			Lowest Temp.	Highest Temp.	Lowest Temp.	Highest Temp.
OFF	OFF	OFF	54° F (12.2° C)	86° F (30.0° C)	54° F (12.2° C)	86° F (30.0° C)
ON	OFF	OFF	56° F (13.3° C)	86° F (30.0° C)	54° F (12.2° C)	84° F (28.9° C)
OFF	ON	OFF	58° F (14.4° C)	86° F (30.0° C)	54° F (12.2° C)	82° F (27.8° C)
ON	ON	OFF	60° F (15.5° C)	86° F (30.0° C)	54° F (12.2° C)	80° F (26.7° C)
OFF	OFF	ON	62° F (16.6° C)	86° F (30.0° C)	54° F (12.2° C)	78° F (25.5° C)
ON	OFF	ON	64° F (17.7° C)	86° F (30.0° C)	54° F (12.2° C)	76° F (24.4° C)
OFF	ON	ON	66° F (18.9° C)	86° F (30.0° C)	54° F (12.2° C)	74° F (23.3° C)
ON	ON	ON	68° F (20.0° C)	86° F (30.0° C)	54° F (12.2° C)	72° F (22.2° C)
#6		#7		Unit Type		
OFF		OFF		Cooling+Electric Heater+Heat Pump		
OFF		ON		Cooling+Electric Heater		
ON		OFF		Heat Pump Only		
ON		ON		Cooling Only		

• **REMOTE/LOCAL CONTROL**

When remote/local switch #1 is on, it allow the unit to operate by the Remote Wall Thermostat. The unit control by knobs are not available.

• **ENERGY SAVER**

The energy saver switch #2 is on. This switch is set at cycle fan to provide continuous fan operation in cool or heat modes. When the switch is off the continuous fan allows continuous circulation of room air and make the more balanced temperature of the room. When the switch is on, the fan is on or off with the compressor or with the heater.

• **FRONT DESK CONTROL**

When the pair wire is connected to the connector FD2 and FD1, the unit can be turned ON or OFF with a switch located at the Front Desk Control panel. When the front desk switch is ON, the fan operates according to the setting without working compressor and heater. When the front desk switch is OFF, the unit can operate according to the setting of controls.

Wire # AWG	Maximum Length
#22	600 ft (180 m)
#20	900 ft (270 m)
#18	1500 ft (450 m)
#16	2000 ft (610 m)

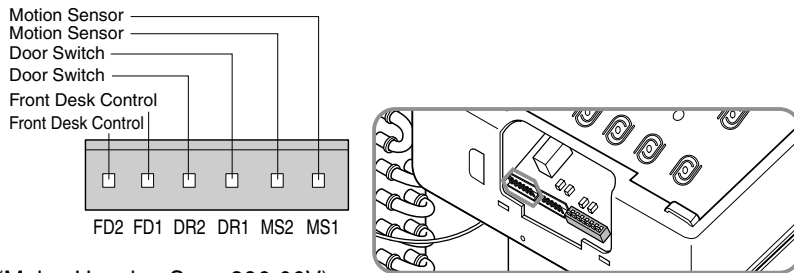

(Molex Housing Spec 396-06V)

• **REMOTE WALL THERMOSTAT**

When the wires are connected, the unit will be controlled by a remote wall thermostat.

The thermostat connections supply the 24 Volt AC. When you install the digital/electronic thermostat, you must set it to 24 Volt AC. See the installation Instruction in this manual for the Remote Wall Thermostat.

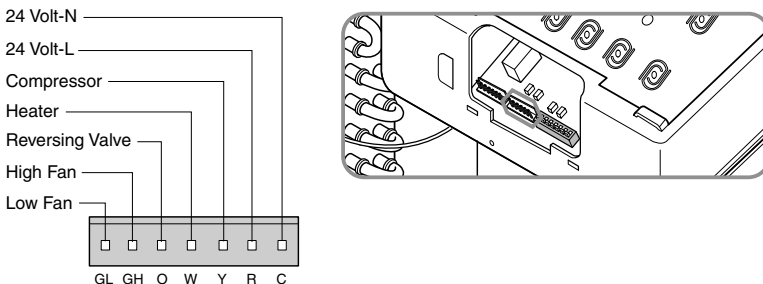

(Molex Housing Spec 396-07V)

Note: The following figures show wiring schematics for heat pump and straight cool units with electric heat, respectively.

Wiring Schematic for Remote Heat Pump

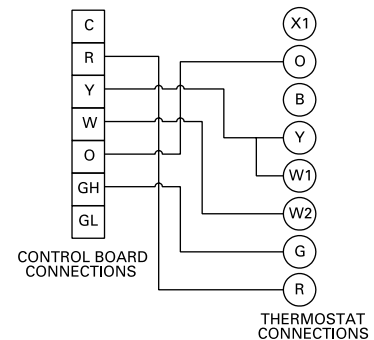

Wiring Schematic for Straight Cool Unit.

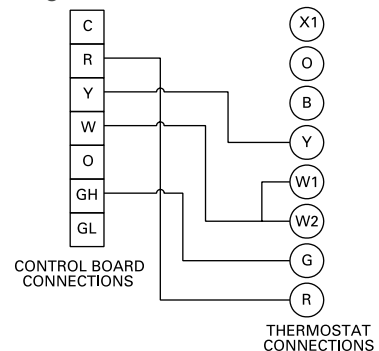

2. Disassembly Instructions

— Before the following disassembly, POWER SWITCH is set to OFF and disconnected the power cord.

2.1 MECHANICAL PARTS

2.1.1 FRONT GRILLE

1. Remove the front grille. (See Figure 1)
2. To remove the front grille, pull out the bottom of the front grille and then lift up.
Re-install the component by referring to the removal procedure.
3. To replace the front grille, place the tabs over the top of the unit and push the bottom of front grille until the clips snap into place.

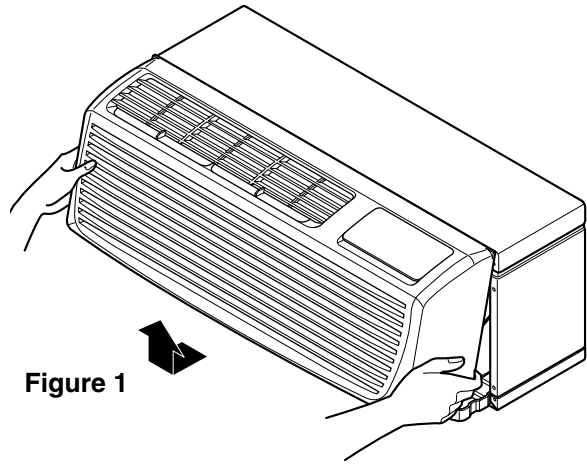

- This Room Air Conditioner (PTAC) discharges air from the top of the unit through reversible, 2-position discharge grille louvers. The unit is shipped from the factory with the discharge grille louvers at an angle of 40° off vertical. In the alternate position, the louvers will be at an angle of 15° off vertical.

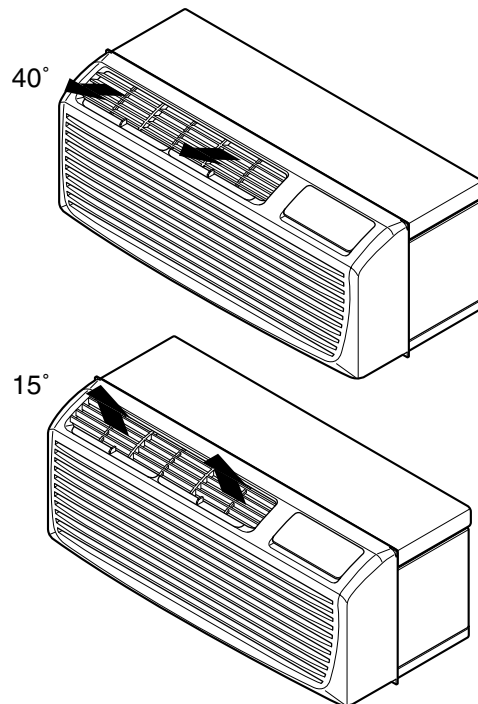

To adjust air direction, remove the front grille. Remove the 4 screws that fasten the discharge grille to the front grille.

Flip the discharge grille 180°, then reattach the discharge grille to the front grille with 4 screws.

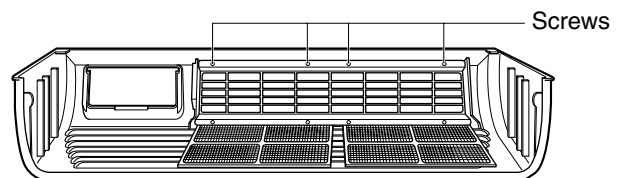

2.1.2 CONTROL BOX

1. Remove the front grille. (Refer to section 2.1.1)
2. Remove the two screws which fasten the control box. (See Figure 2)
3. Pull the control box from the Air guide.

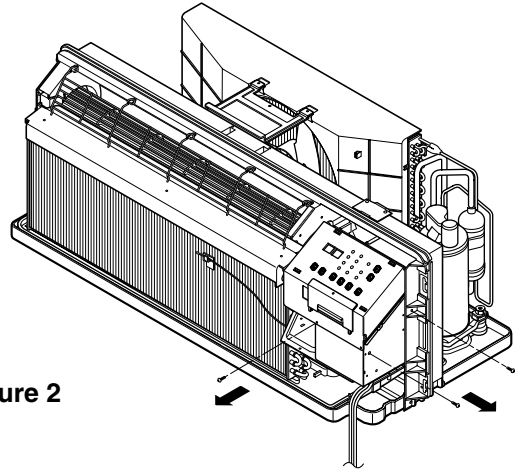

Figure 2

4. Remove the control box cover. (See Figure 3)
5. Disconnect wire housings on the control box.

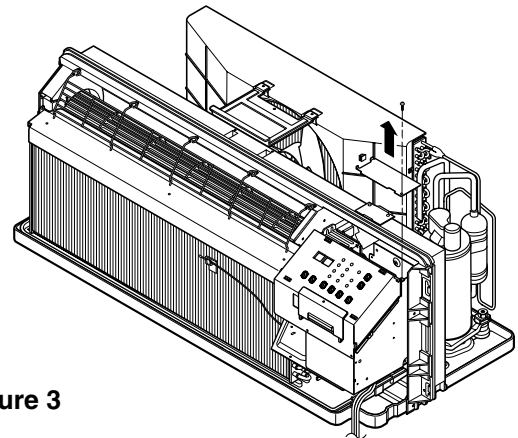

Figure 3

6. Pull the control box assembly out from the unit. (See Figure 4)
7. Re-install the components by referring to the removal procedure.

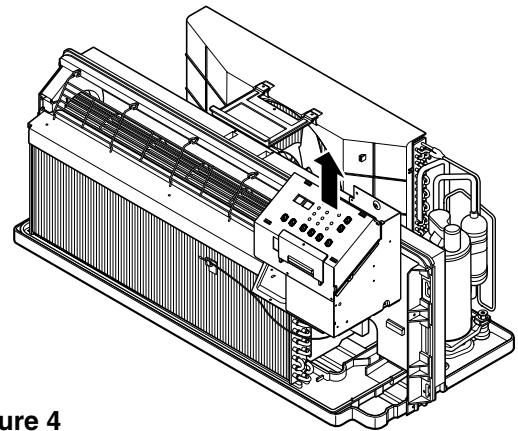

Figure 4

2.2 AIR HANDLING PARTS

2.2.1 ELECTRIC HEATER (ELECTRIC HEATER MODEL ONLY)

1. Remove the front grille.(Refer to section 2.1.1)
2. Remove the control box assembly.
(Refer to section 2.1.2)
3. Remove the 4 screws which fasten the Evaporator.
(See Figure 5)

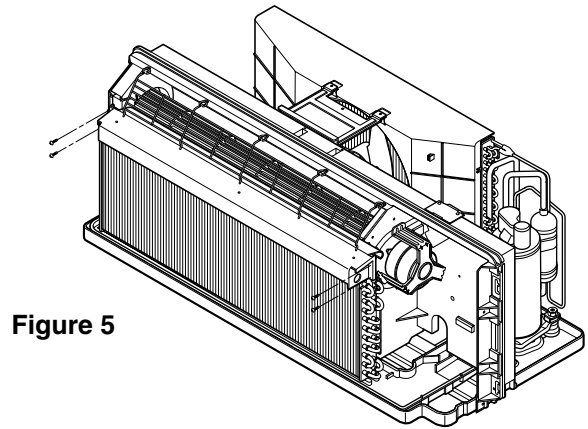

Figure 5

4. Remove the top cover assembly, net steel, brace.
(See Figure 6)

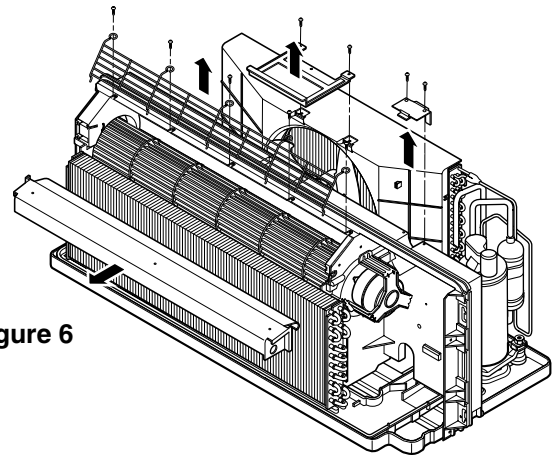

Figure 6

5. Remove the 6 screws which fasten the Air-guide.
6. Pull the Air-guide assembly out from the unit.
(See Figure 7)

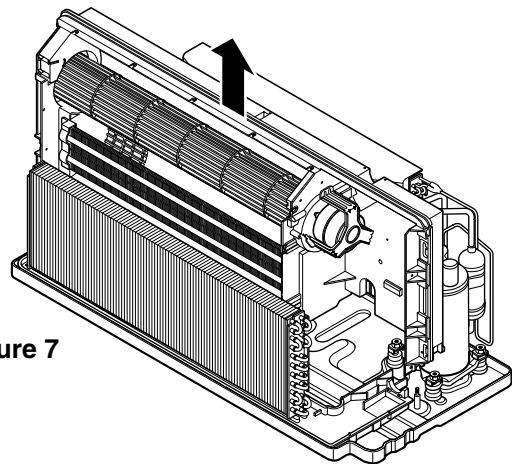

Figure 7

7. Remove the 2 screws which fasten the electric heater in the left hand side.
8. Pull the electric heater towards left for a while and then lift up vertically to disassemble it completely from Air guide.

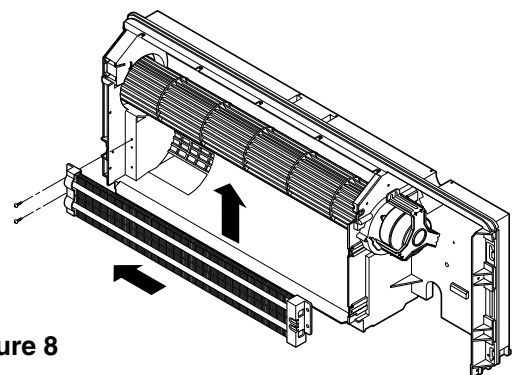

Figure 8

2.2.2 CROSS FLOW FAN

1. Remove the front grille. (Refer to section 2.1.1)
2. Remove the control box assembly.
(Refer to section 2.1.2)
3. Remove the Air-Guide Assembly from the unit.
(Refer to section 2.2.1)
4. Loosen the screw on the cross flow fan.
(See Figure 9)

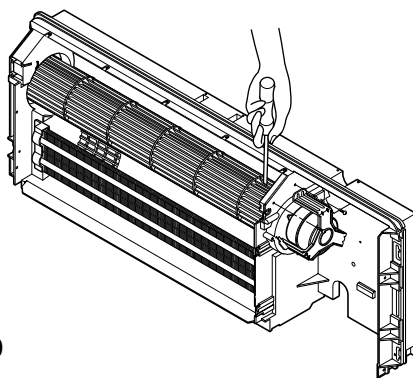

Figure 9

5. Remove the 4 screws which fasten the indoor motor and the earth wire. (See Figure 10)
6. Remove the supports on both sides.
7. Pull the cross flow fan out from the air-guide.
8. Re-install the components by referring to the removal procedure.

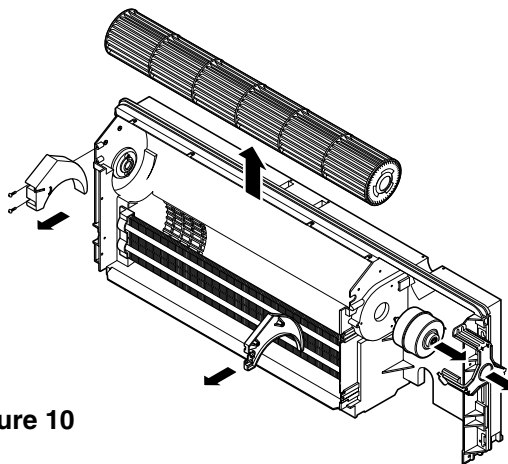

Figure 10

2.2.3 AXIAL FAN

1. Remove the brace.
2. Remove the 4 screws which fasten the condenser with the shroud and the basepan. (See Figure 11)
3. Remove the condenser sideways carefully.

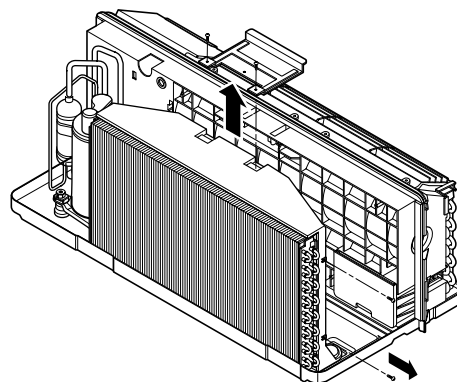

Figure 11

4. Remove the clamp which secures the fan with pliers. (See Figure 12)
5. Remove the axial fan.
6. Re-install the components by referring to the removal procedure.

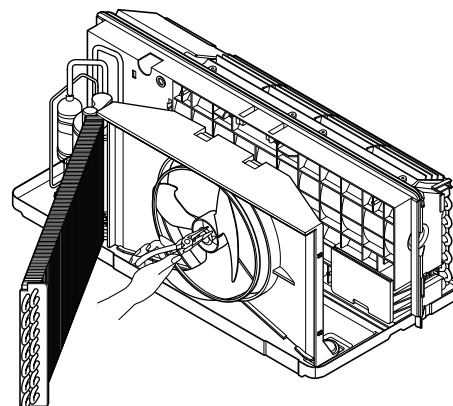

Figure 12

2.2.4 SHROUD

1. Remove the axial fan. (Refer to section 2.2.3)
2. Remove the 4 screws which fasten the condenser with the shroud and the basepan. (See Figure 11)
3. Remove the shroud.
4. Re-install the component by referring to the removal procedure.

2.3. ELECTRICAL PARTS

2.3.1 OUTDOOR MOTOR

1. Remove the clamp cord and disconnect a wire housing in control box. (Refer to section 2.1.2)
2. Remove the axial fan. (Refer to section 2.2.3)
3. Remove the 2 screws which fasten the motor. (See Figure 12)
4. Remove the motor
5. Re-install the component by referring to the removal procedure, above.

2.3.2 INDOOR MOTOR (Refer to section 2.2.2)

2.3.3 COMPRESSOR

1. Discharge the refrigerant system using a refrigerant recovery system.
If there is no valve to attach the recovery system, install one (such as a WATCO A-1) before venting the refrigerant. Leave the valve in place after servicing the system.
2. Disconnect the 3 leads from the compressor.
3. After purging the unit completely, unbraid the suction and discharge tubes at the compressor connections.
4. Remove the 3 nuts and the 3 washers which fasten the compressor. (See Figure 15)
5. Remove the compressor.
6. Re-install the components by referring to the removal procedure, above.

2.3.4 CAPACITOR

1. Remove the control box. (Refer to section 2.1.2)
2. Remove 1 screw and disconnect the leads which connected to the box type capacitor. (See Figure 16)
3. Remove 1 screw and the clamp which fastens the can-type capacitor.
4. Disconnect all the leads of capacitor terminals.
5. Re-install the components by referring to the removal procedure, above.

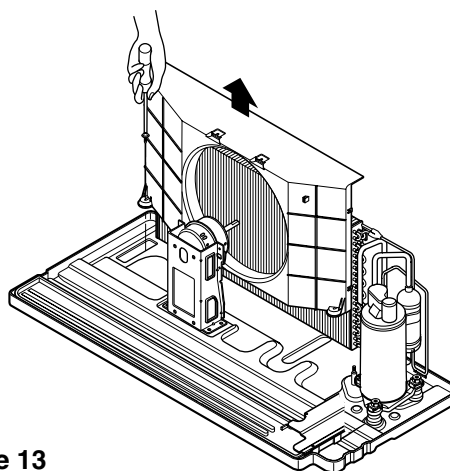

Figure 13

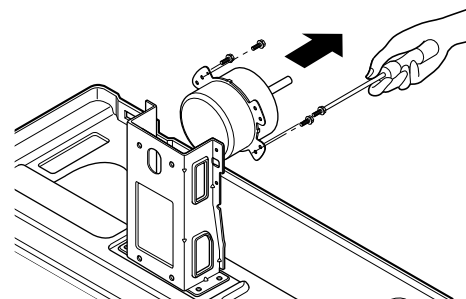

Figure 14

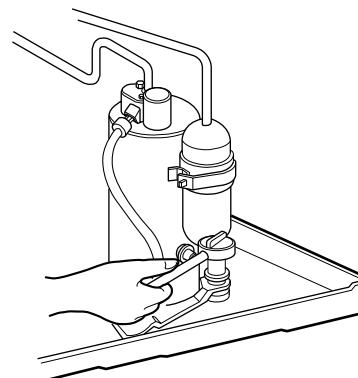

Figure 15

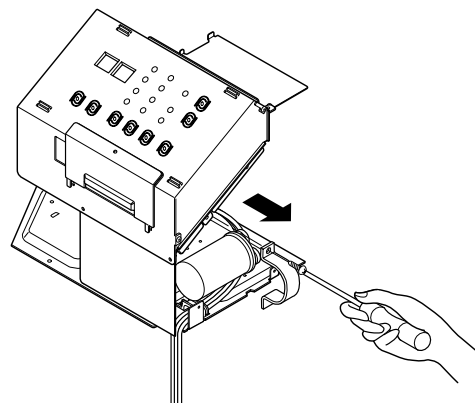

Figure 16

2.3.5 POWER CORD

1. Remove the control box. (Refer to section 2.1.2)
2. Disconnect the grounding screw from the control box.
3. Disconnect 2 receptacles.
4. Remove a screw which fastens the clip cord.
5. Separate the power cord from the control box. (See Figure 17)
6. Re-install the component by referring to the removal procedure, above. (Use only one ground-marked hole \oplus for ground connection.)
7. If the supply cord of this appliance is damaged, it must be replaced by an exact replacement part. (The special cord means the cord which has the same specification marked on the supply cord fitted to the unit.)

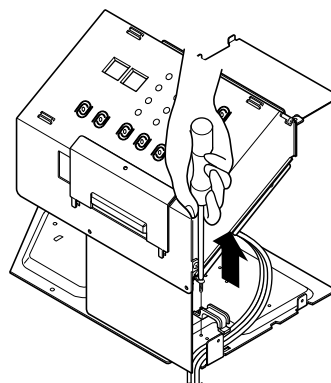

Figure 17

2.3.6 PWB

1. Remove the screw which fasten PWB cover.
2. Disconnect all the leads which connected to the PWB.
3. Remove the two screws which fasten the PWB board.
4. Re-install the components by referring to the removal procedure, above.

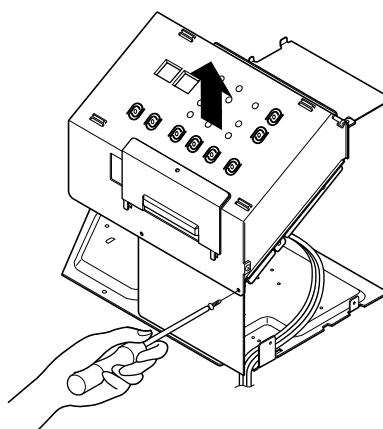

Figure 18

WARNING

After servicing control box, make sure that AC and DC wires are separated and tied up properly.

The wires should also be pressed a little downwards to prevent touching it to the display PWB.

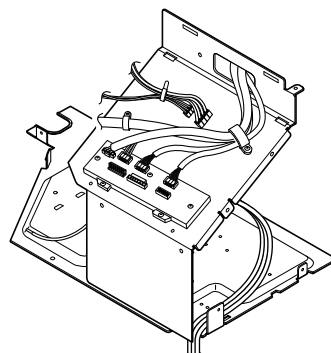

Figure 19

2.4 REFRIGERATION CYCLE

CAUTION

Discharge the refrigerant system using a refrigerant recovery system.
If there is no valve to attach the recovery system, install one (such as a WATCO A-1) before venting the refrigerant. Leave the valve in place after servicing the system.

2.4.1 CONDENSER

1. Remove the brace and the shroud.
(Refer to section 2.2.2)
2. Remove the 4 screws which fasten the shroud.
(Refer to section 2.2.2)
3. Push forward the shroud and remove the 2 screws which fasten the condenser with the basepan.
4. After discharging the refrigerant completely, unbrazed the interconnecting tube at the condenser connections.
5. Remove the condenser.
6. Re-install the components by referring to notes.
(See Figure 20)

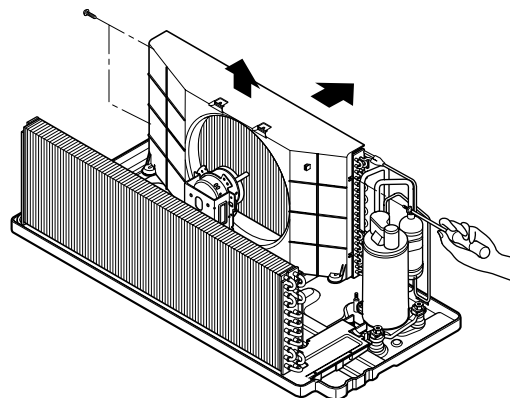

Figure 20

2.4.2 EVAPORATOR

1. Remove the front grille. (Refer to section 2.1.1)
2. Discharge the refrigerant completely.
3. Remove the control box assembly.
(Refer to section 2.1.2)
4. Remove the 4 screws which fasten the evaporator at the left side and the right side.
5. Move the evaporator sideward carefully and then unbrazed the interconnecting tube at the evaporator connectors.
6. Remove the evaporator.
7. Re-install the components by referring to notes.
(See Figure 21)

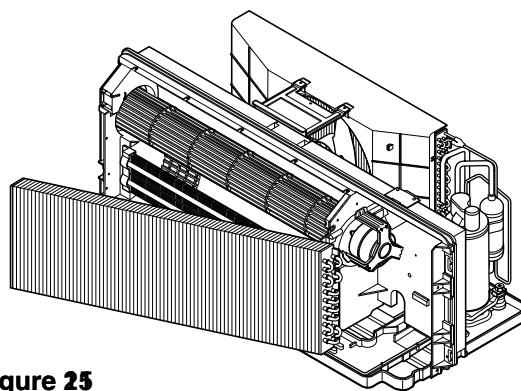

Figure 25

2.4.3 CAPILLARY TUBE

1. After discharging the refrigerant completely, unbrazed the interconnecting tube at the capillary tube.
2. Remove the capillary tube.
3. Re-install the components by referring to notes.

NOTES

— Replacement of the refrigeration cycle.

1. When replacing the refrigeration cycle, be sure to discharge the refrigerant system using a refrigerant recovery system.
If there is no valve to attach the recovery system, install one (such as a WATCO A-1) before venting the refrigerant. Leave the valve in place after servicing the system.
2. After discharging the unit completely, remove the desired component, and unbraid the pinch-off tubes.
3. Solder service valves into the pinch-off tube ports, leaving the valves open.
4. Solder the pinch-off tubes with service valves.
5. Evacuate as follows.
 - 1) Connect the vacuum pump, as illustrated Figure 22A.
 - 2) Start the vacuum pump, slowly open manifold valves A and B with two full turns counterclockwise and leave the valves closed. The vacuum pump is now pulling through valves A and B up to valve C by means of the manifold and entire system.

CAUTION

If high vacuum equipment is used, just crack valves A and B for a few minutes, then open slowly with the two full turns counterclockwise. This will keep oil from foaming and being drawn into the vacuum pump.

- 3) Operate the vacuum pump for 20 to 30 minutes, until 600 microns of vacuum are obtained. Close valves A and B, and observe the vacuum gauge for a few minutes. A rise in pressure would indicate a possible leak or moisture remaining in the system. With valves A and B closed, stop the vacuum pump.
- 4) Remove the hose from the vacuum pump and place it on the charging cylinder. See Figure 22 B. Open valve C.
Discharge the line at the manifold connection.
- 5) The system is now ready for final charging.

6. Recharge as follows :

- 1) Refrigeration cycle systems are charged from the high-side. If the total charge cannot be put in the high-side, the balance will be put in the suction line through the access valve which you installed as the system was opened.
- 2) Connect the charging cylinder as shown in Figure 22B.
With valve C open, discharge the hose at the manifold connection.
- 3) Open valve A and allow the proper charge to enter the system. Valve B is still closed.
- 4) If more charge is required, the high-side will not take it. Close valve A.
- 5) With the unit running, open valve B and add the balance of the charge.
 - a. Do not add the liquid refrigerant to the low-side.
 - b. Watch the low-side gauge; allow pressure to rise to 30 lbs.
 - c. Turn off valve B and allow pressure to drop.
 - d. Repeat steps B and C until the balance of the charge is in the system.
- 6) When satisfied the unit is operating correctly, use the pinch-off tool with the unit still running and clamp on to the pinch-off tube. Using a tube cutter, cut the pinch-off tube about 2 inches from the pinch-off tool. Use sil-fos solder and solder pinch-off tube closed. Turn off the unit, allow it to set for a while, and then test the leakage of the pinch-off connection.

Equipment needed: Vacuum pump, charging cylinder, manifold gauge, brazing equipment, pinch-off tool capable of making a vapor-proof seal, leak detector, tubing cutter, hand tools to remove components, service valve.

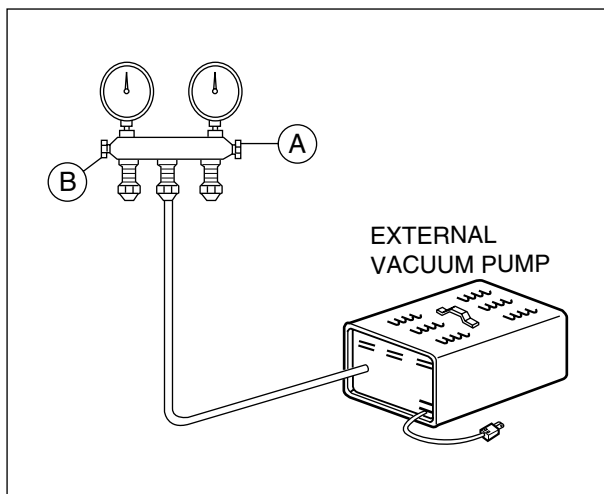
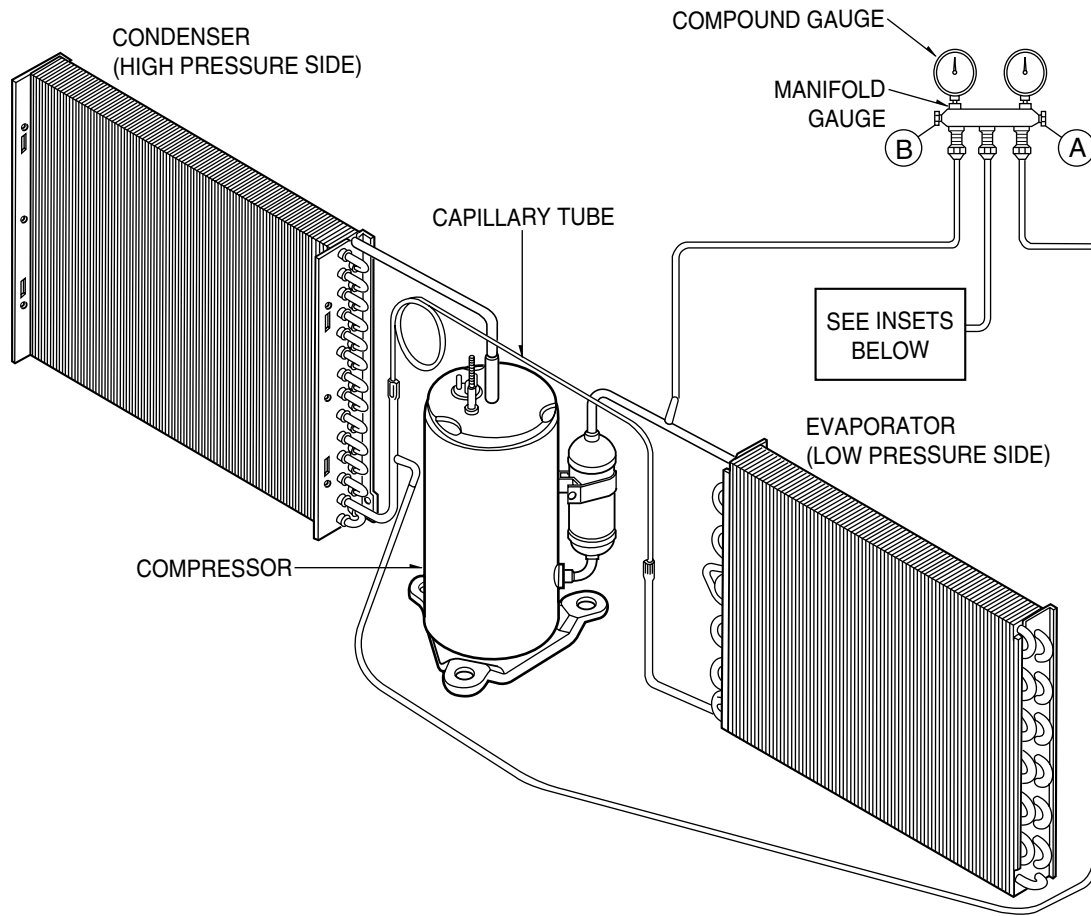

Figure 22A-Pulling Vacuum

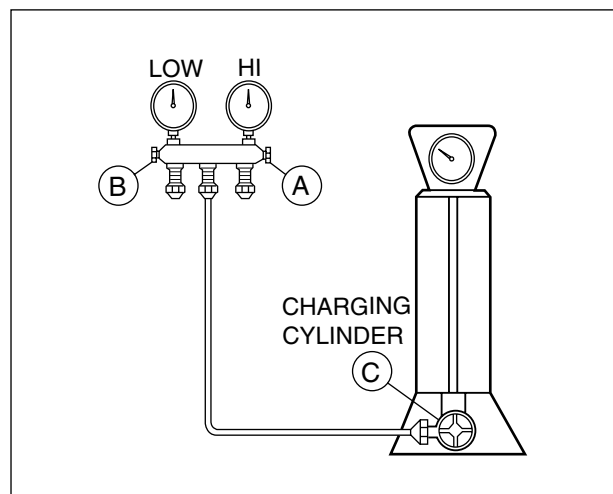

Figure 22B-Charging

3. Installation

3.1 HOW TO INSTALL THE UNIT

CAUTION

- There are sharp edges that can cause serious cuts.
- When lifting the air conditioner, it is HEAVY. Use 2 people to lift.

For existing sleeve, you should measure the wall sleeve dimensions.

Install the new air conditioner according to these installation instructions to achieve the best performance. All wall sleeves used to mount the new air conditioner must be in good structural condition and have a rear grille that securely attaches to the sleeve or the flange of the sleeve to secure the new air conditioner.

- To avoid vibration and noise, make sure the unit is installed securely and firmly.

When installing the sleeve, make certain there is nothing within 20" of the back that would interfere with heat radiation and exhaust air flow.

Dimension of air conditioner

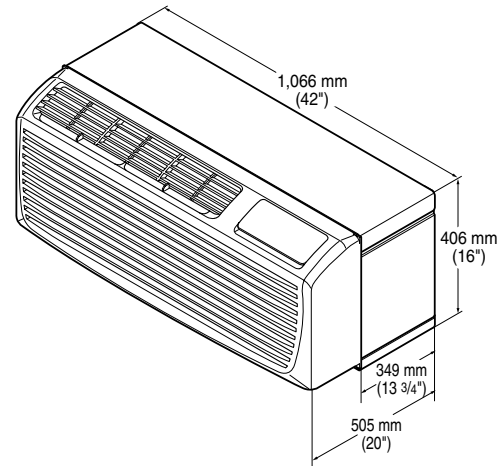

Dimension of sleeve assembly (optional)

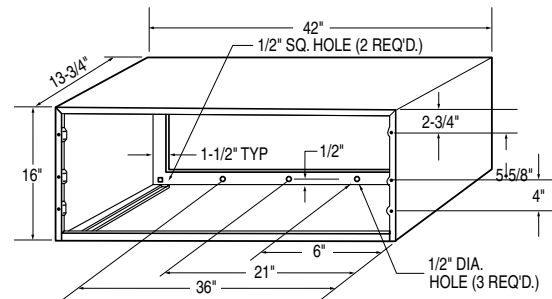

Wall opening 16-1/4"x42-1/4"

Recommended Insulation strip must be attached to prevent the re-circulation of exhaust air to inward side from the either side of condenser space. The insulation strip is provided with the box. Refer to the diagram below.

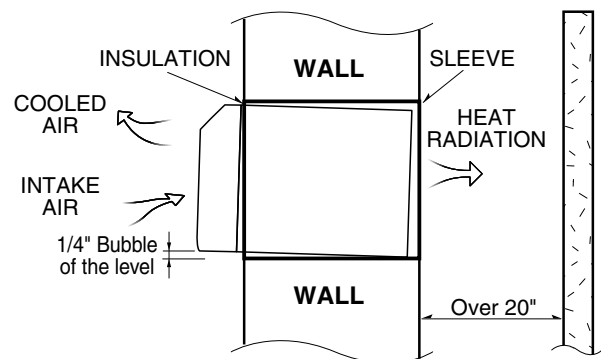
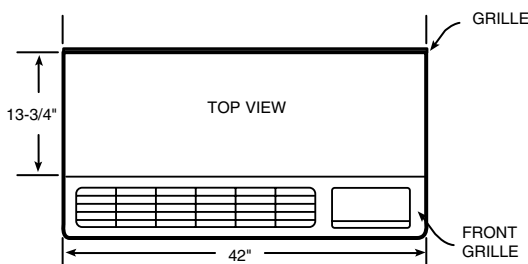

- 1) Take out the insulation strip from the upper packing.
- 2) Attach the insulation strip onto the rear upper side of the wall sleeve.
- 3) To improve unit energy efficiency, it is recommended the change of outside grille for a unit protection and an addition of a plastic rear grille. (This is optional.)
- 4) Insulation strip prevents the exhaust air from re-entering from either side of condenser space which may decrease the cooling efficiency of condenser.

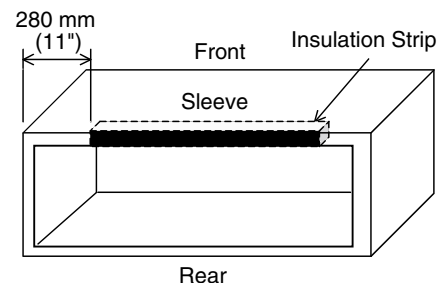

3.2 WALL SLEEVE INSTALLATION

3.2.1 Wall Case Installation Data

General

Generally, units are installed 3" to 5" above the floor (flush to finished floor installation is possible) as near to the center of the room as possible; underneath a window or a glass panel is typical. Normal installation of the wall case allows installation flexibility; from flush with the finished interior wall to a minimum of 1/4" of the wall case extending beyond the finished exterior of the building.

Special consideration must be given to installations where the wall case does not extend a minimum of 1/4" beyond the finished exterior wall.

Regardless of the installation, there are several things to consider when selecting a location for installing the unit. For instance, drapery location could interfere with air discharge, and placement of furniture may have an impact on the performance of the unit. The following information is intended to minimize installation problems and assure you of trouble-free installation.

Refer to page 18 for required wall opening dimensions. Minimum recommended interior and exterior case projection for standard wall thicknesses are shown in the drawings in this manual. The case may be installed flush with the finished indoor wall.

Mounting an outdoor grille or louver section to the building face may cause a space between the outdoor coil and the louver section. Air splitters, aligned with the ends of the outdoor coil, must be installed between the outdoor coil inlet and outlet air streams. Gaps between the outdoor coil and the louver section may allow condenser air recirculation and affect the operation of the unit. See page 18 for requirements for custom louver sections.

NOTE

The wall case should be level from side to side and from level to 1/4 bubble tilt to the outdoors. The condensate disposal system in the unit is designed to dissipate the condensate water generated during cooling operation in accordance with ARI standards and actually uses this water for maximum unit efficiency. A level unit will also insure proper performance of the Internal Condensate Removal (ICR) system optional on heat pump units.

For new construction, early planning with the architect is necessary. Unit location, electrical connection locations, and wall openings of the proper dimensions are essential to avoid the necessity of rework, fillers, framing, moving electrical outlets, and other expensive modifications.

For existing construction it is important that carpentry, masonry and electrical work be performed by competent, qualified personnel. **Since installations in existing construction may involve removal of building material from the structure, locating the wall case must be done correctly.**

3.2.2 PREPARATION OF THE FRONT GRILLE

Carefully remove shipping tape from the front grille.

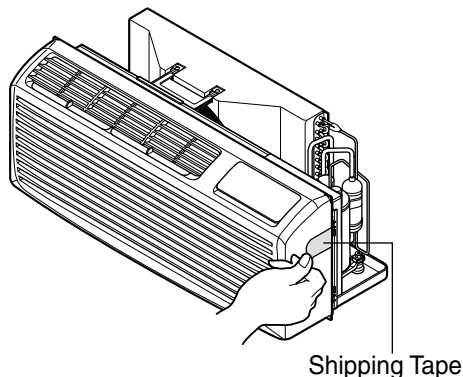

Brick, Frame, Stucco and Shingle Construction

For new construction, the opening for the wall case should be framed and the wall case inserted into the opening during construction. Lintels should be used when the building material is heavy and is not self supporting (such as brick). The wall case will fit an opening of six courses of standard brick or five courses of jumbo brick. Wall framing in this type construction is normally on 16" centers and the wall case will fit a framed opening spanning three 16" O.C. 2" x 4" stud spaces.

For existing construction the indoor and outdoor wall will need to be cut out, allowing for clearances of 1/8" on all sides of the wall case. Work should begin on the inside wall.

Cut the correct dimensions and mark (using drill holes) the outside wall from each corner of the inside cutout. Studding that interferes with the opening must be removed and a suitable frame constructed to secure the wall case and provide adequate support for case and chassis.

Preparation of the Wall Case for All Types of Construction

As shipped, the LG wall sleeve is ready for installation. Do not remove the stiffener from inside the wall case or the weather closure panel from the outside face of the wall case until the outdoor grille and chassis are ready to be installed.

Installation of Wall Case in Wall Opening

1. Position the wall case into the wall. The room side edge of the wall case should be at least flush with the finished wall for line cord installations and permanent connection installations when no sub-base is used, and should project into the room at least 2-3/8" when a sub-base is used. If the minimum exterior dimensions are not met, refer to page 21.

The outside edge of the wall case should extend at least 1/4" beyond the outside wall.

This is necessary for proper caulking, to prevent sealing the drain holes in the rear flange of the wall case, and to facilitate the installation of an accessory drain, if used.

2. The wall case should be secured to the wall at both sides. Use a minimum of two screws or other fastening device on each side. See Figure 2 page 23B. Mark the wall case on each side 2" from the bottom and 2" from the top at a point where basic wall structure is located. Drill wall case and use fasteners appropriate for wall construction. All holes for fasteners in the side of the wall case must be at least 2" up from the bottom of the wall case. **Never locate screws or put other holes in the bottom of the wall case.**

If the wall opening is greater than the case dimensions, spacers must be used on the sides between the wall case and the wall support structure to prevent distorting the wall case.

3. Caulk or gasket the entire opening on the outside between the wall case and exterior wall surface (4 sides) to provide total water and air seal.
4. Caulk or gasket room-side opening between wall case and interior wall surface (4 sides). Opening beneath or around the wall case can allow outdoor air to leak into the room resulting in increased operating costs and improper room temperature control.

Care should be taken in location of electrical supply entry in relationship to wall sleeve to assure access to receptacle or junction box once unit is installed.

The wall case should be level from side to side and from level to 1/4 bubble tilt to the outdoors. The condensate disposal system in the unit is designed to dissipate the condensate water generated during cooling operation in accordance with ARI standards and actually uses this water for maximum unit efficiency. A level unit will also insure proper performance of the Internal Condensate Removal (ICR) system optional on heat pump units.

**FRAMING FOR WALL CASE
BRICK VENEER AND FRAME CONSTRUCTION**

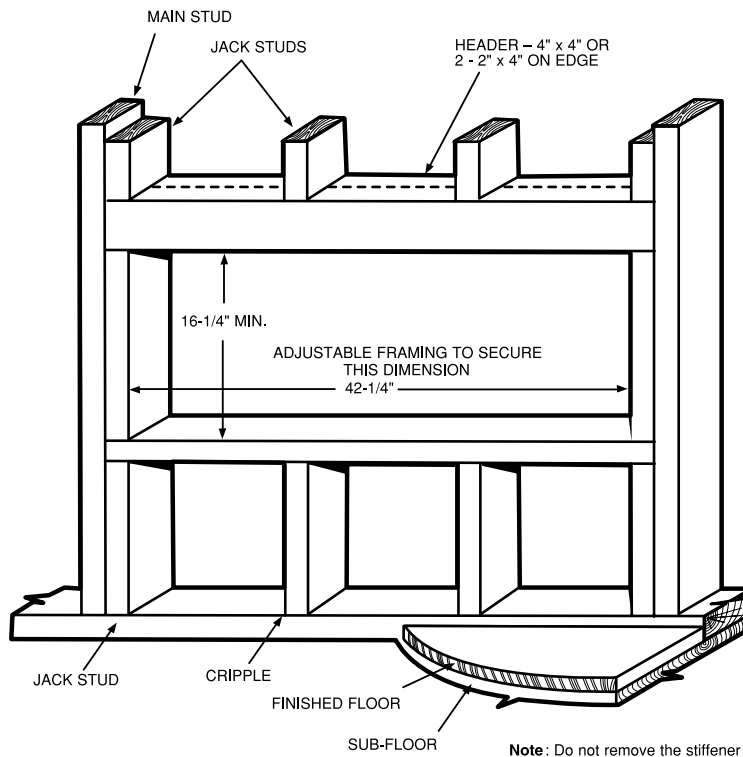

Note: Do not remove the stiffener support from inside the wall case until the chassis is to be installed.

FASTENING WALL CASE

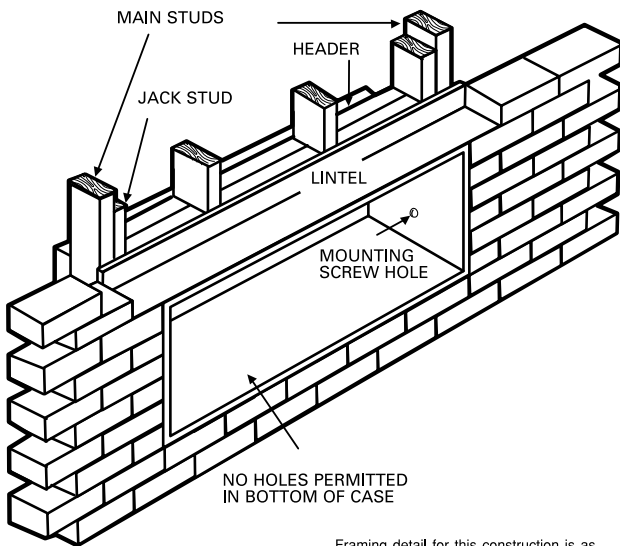

Framing detail for this construction is as shown in Figure 1. Note use of lintel under first course of brick above the wall case. Do not use the case as a lintel. Mounting screw holes shown are to be made by the installer.

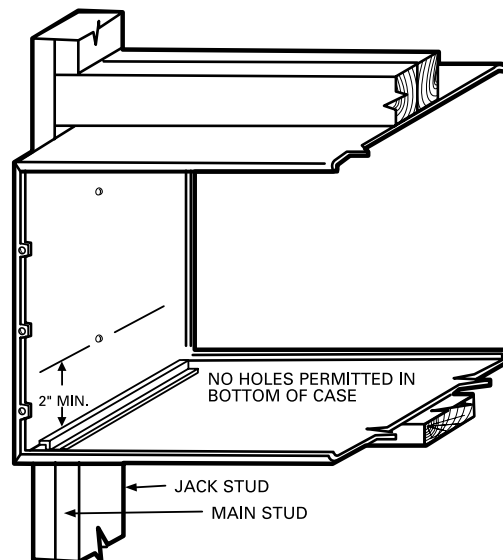

Choice of attachment devices through both ends of case or the top. Mounting screw holes and attachment devices by installer.

**WALL SECTION - DETAILED SIDE VIEW
FRAME AND BRICK VENEER INSTALLATION**

Sub-Base Connected

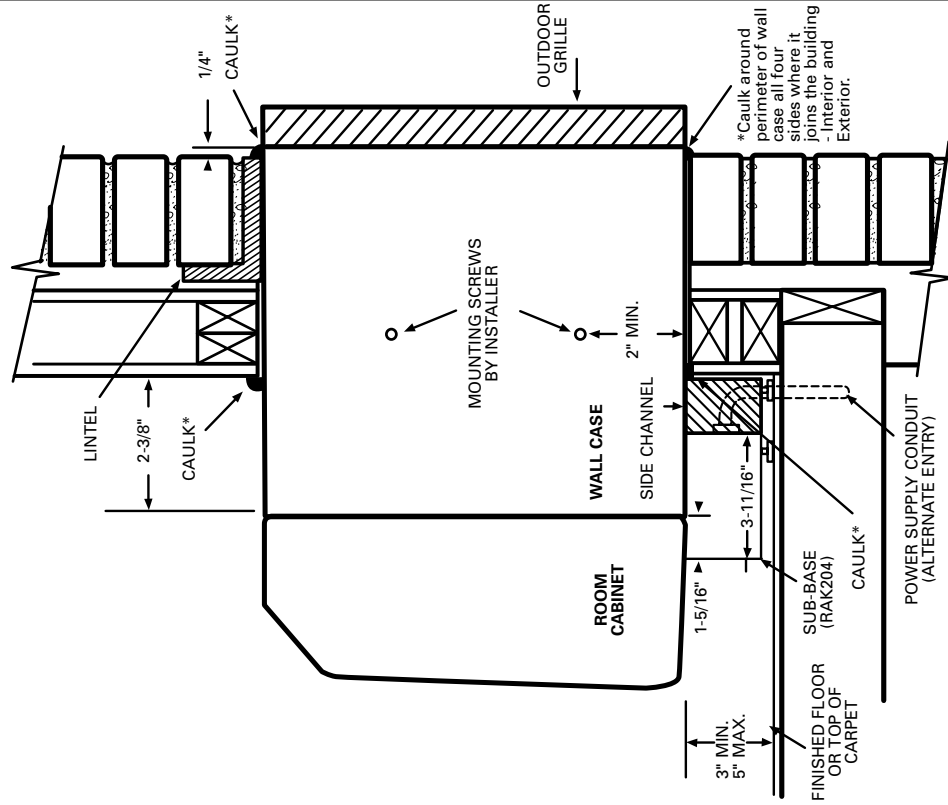
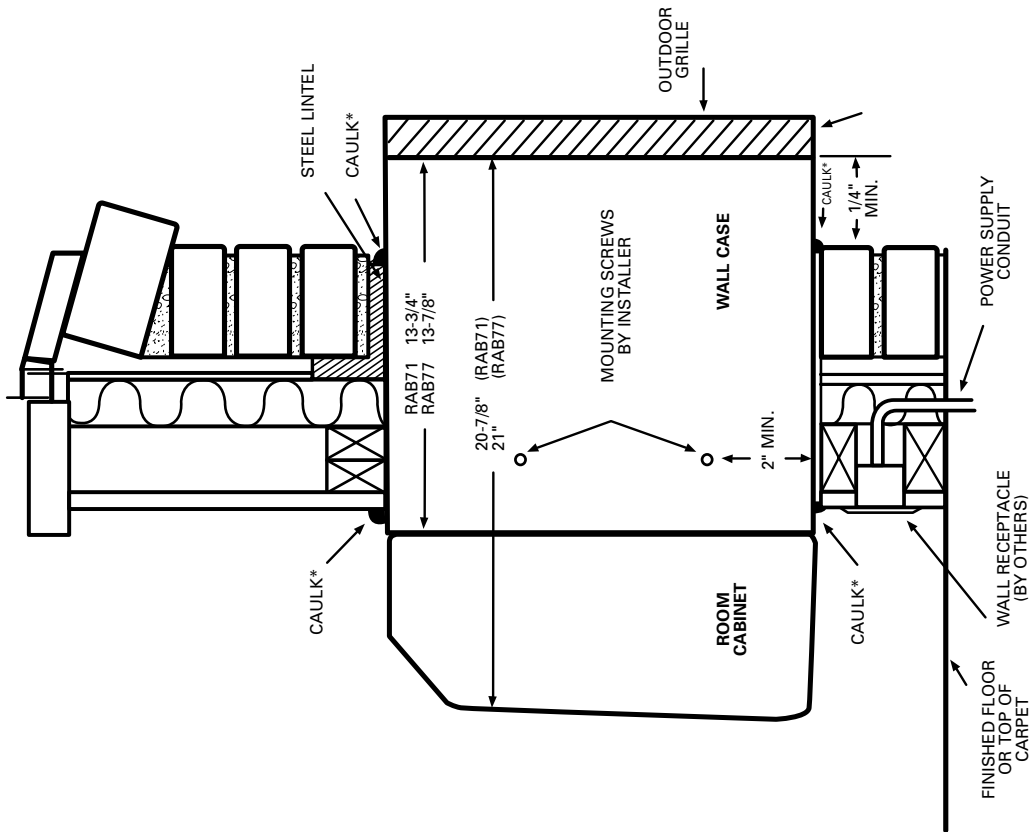

Figure 23B

Cord Set Connected



*Caulk around perimeter of wall case all four sides where it joins the building - Interior and Exterior.

Figure 23A

3.2.3 UNIT INSTALLATION

1. Remove the shipping screw from the ventilation door.
(See Figure 24)

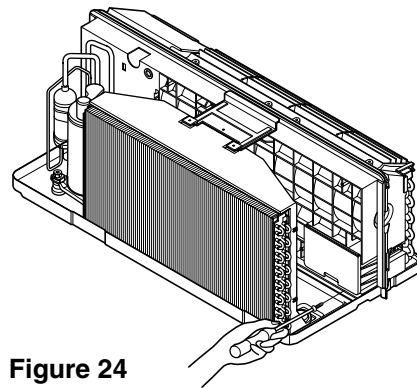

Figure 24

2. Remove the front grille by pulling it out at the bottom to release it, then lift it up along the unit top front.
(See Figure 25)

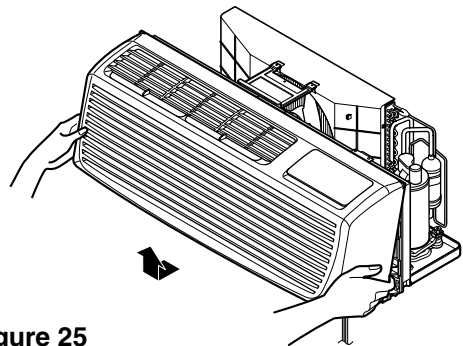

Figure 25

3. Slide the unit into the wall sleeve and secure with 6 screws through the unit flange holes. (See Figure 26)

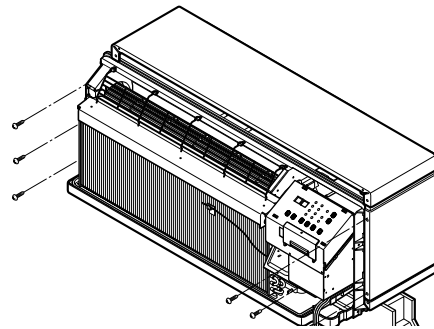

Figure 26

4. Reinstall the front grille by hooking the top over the unit top, then pushing it in at the bottom. (See Figure 27)

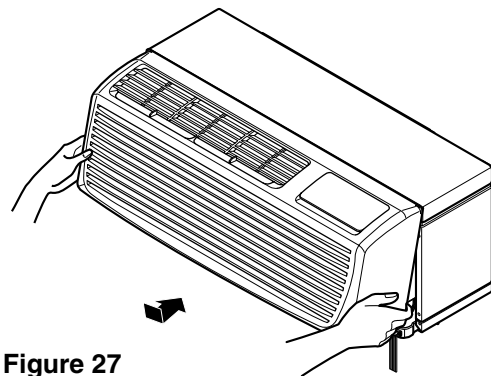

Figure 27

3.3 ELECTRICAL REQUIREMENTS

3.3.1 ELECTRICAL DATA (FOR 230/208V MODEL)

CAUTION

1. Do not use an extension cord with this unit.
2. When the unit is in the OFF position, the power supply to the electrical controls is still energized.
3. Disconnect the power to the unit before servicing the unit.
4. Remove the power cord from the wall receptacle.
5. Remove or turn off the protective device (fuses or circuit breaker).

Wirings including installation of the receptacle must comply with the NEC and local codes, local regulations.

FUSE- Use a time-delay fuse or circuit breaker. Refer to the nameplate for proper power supply requirements.

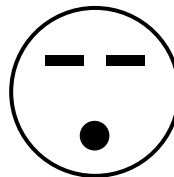

Tandem
15 A

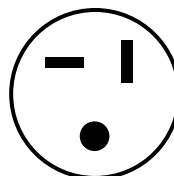

Perpendicular
20 A

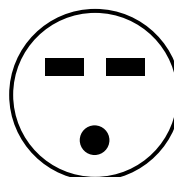

Large Tandem
30 A

230/208 volt receptacle configuration

3.3.2 ELECTRICAL SAFETY

IMPORTANT GROUNDING INSTRUCTIONS

The air conditioner has a three-prong grounding plug on its power supply cord which must be plugged into properly grounded three-prong wall receptacle for your protection against possible shock hazard.

FUSE – Use a time-delay fuse or circuit breaker. Refer to the nameplate for proper power supply requirements.

208, 230, and 208/230 VOLT UNITS

These units are equipped with a three-prong grounding plug on the power supply cord which must be plugged into a matching properly grounded three-prong wall receptacle for your protection against possible shock hazard. If such an outlet is not present, one must be installed by a qualified electrician in accordance with the National Electrical Code and local codes and ordinances.

NOTE: DO NOT USE AN EXTENSION CORD on 208, 230, and 208/230 Volt units.

4. Field installed accessories

Note: The installation and servicing of this equipment must be performed by qualified, experienced technicians

NOTICE:

Warnings and Cautions appear at appropriate sections throughout this manual. Read these carefully.

⚠ WARNING - Indicates a potentially hazardous situation which, if not avoided, could result in death or serious injury.

⚠ CAUTION - Indicates a potentially hazardous situation which, if not avoided, may result in minor or moderate injury. It may also be used to alert against unsafe practices.

CAUTION –Indicates a situation that may result in equipment or property-damage-only accidents.

Control Panel Key Lock

Part No: AYCP101

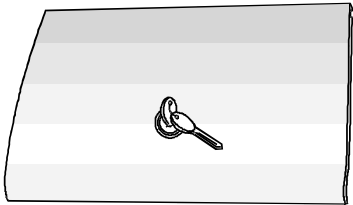

Description

The Key Lock kit prevents tampering of the controls used to set temperatures and heating or cooling functions.

Receiving

Upon receipt of the product, inspect the shipping carton for signs of visible damage. Report any damage or shortage to the carrier and note it on the delivery receipt. Unit must be stored in its original shipping carton in a dry, secure place prior to its installation and use.

Installation

The installation and servicing of the equipment referred to in this booklet should be performed by qualified, experienced technicians.

1. Remove front from unit by pulling bottom out and then lifting upward. (Figure 28)

Figure 28 - Remove Front

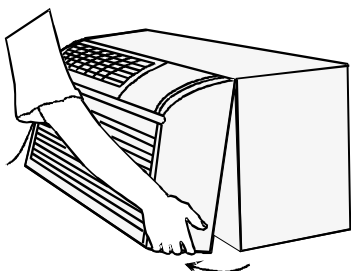

2. Remove existing door assembly by lifting door halfway and using both hands, bow door just enough for door hinge pins to slide out of mating holes. (Figure 29)

Figure 29 - Door Removal

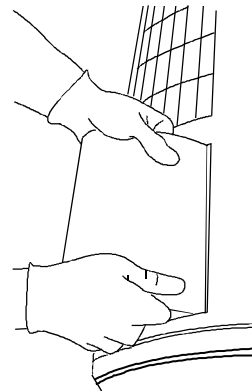

3. Install the new door assembly with the key lock by bowing the door with both hands and aligning the door hinge pins with their bracket in the front. (Figure 30)

Important Note:

Personal Risk Hazard Underwriter's Laboratories Inc. listed. For institutional use only where supervisory monitoring is available.

Any other use may increase the risk of personal injury or property damage.

Figure 30 - New Door Installation

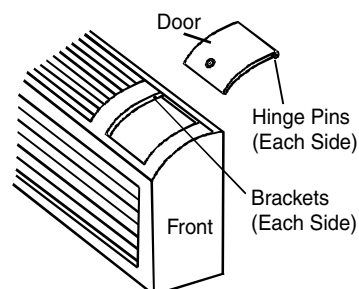

Condensate Disposal Pump Kit Installation

Part No: AYSB2101

Description

The internal condensate pump serves as a means for disposing of condensate generated during heat pump operation by transferring it to the indoor coil. The warm coil surface and the warm room air help in evaporation of the condensate while adding humidity to the room.

As with any equipment of this type, the addition of this kit will decrease the effective heating capacity of the unit. This kit is not intended for use in seacoast or corrosive environments.

NOTE:

Under extreme high humidity conditions, the internal condensate pump may not be able to dispose of all the condensate produced, and condensate would then drip from the outside of the wall sleeve. If this condensation is unacceptable, then a drain system (including factory approved drain kit for the wall sleeve) should be installed.

Receiving

Upon receipt of the product, inspect the shipping carton for signs of visible damage. Report any damage or shortage to the carrier and note it on the delivery receipt. Unit must be stored in its original shipping carton in a dry, secure place prior to its installation and use.

Installation

The installation and servicing of the equipment referred to in this booklet should be performed by qualified, experienced technicians.

WARNING

Hazardous Voltage!

Disconnect all electric power, including remote disconnects before servicing. Follow proper lockout/tagout procedures to ensure the power can not be inadvertently energized. Failure to disconnect power before servicing could result in death or serious injury.

Important Note:

The unit OFF switch does not disconnect all electrical power to this unit.

1. Remove front plastic cover by rotating bottom outward and then lifting up and out from chassis.
2. Unplug and remove the PTAC chassis from the wallsleeve. Move the chassis where the front and back of the chassis can be easily accessed.
3. Remove the wire junction box cover by removing four screws and lifting up as shown in fig. 31

Figure 31

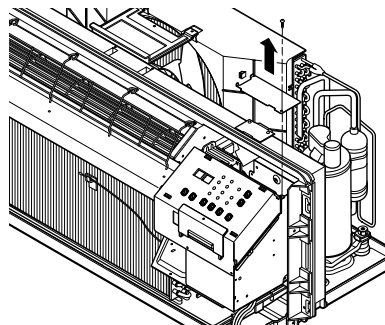

4. Remove and set aside the air discharge screen by unscrewing the 5 screws on the top.
5. Remove the one screws holding the control board cover as shown fig. 32. Remove the cover by lifting it up so its free from its hinges, and put aside.

Figure 32

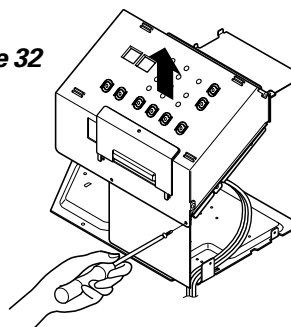

6. Unplug the electric heater connector located inside the wire junction box.

7. Remove the screw that attaches the electric heater wire to the side of the indoor fan housing.
8. Remove the 3 screws which fasten the top cover assembly.

Figure 33

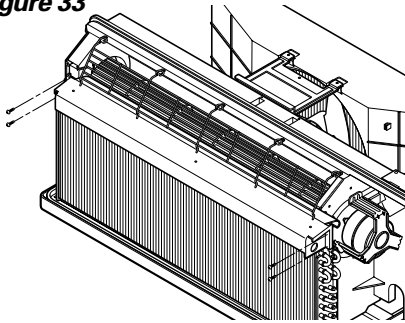

9. Position water spraying plastic tube into the electric heater cover. Make sure that the three pairs (total of six) of plastic tongues snap into the corresponding metal slots of the heater frame as shown in fig. 34. Then install one of the three rubber elbows (ref. fig. 38) at the inlet of the spraying tube and through the rubber grommet.

Figure 34

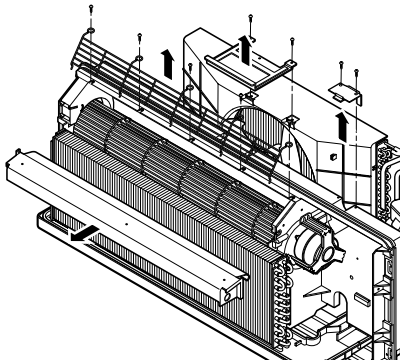

10. Place the top cover assembly back into the unit.

11. Install tube #1 and tube #2 (ref. fig. 38) on the pump assembly using the rubber elbows as shown in fig. 28.

Figure 35

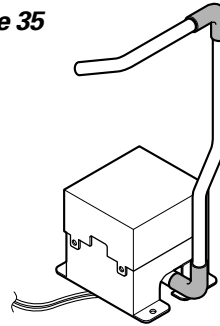

12. Position pump assembly to the basepan as shown in fig. 36 and fasten the pump bracket to the basepan using the three screws provided.

Figure 36

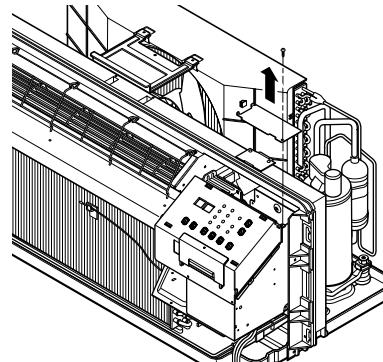

13. Insert tube #2 of the pump assembly through the plastic grommet of the sheet metal partition as shown in fig. 37. Then connect the end of tube #2 to the plastic elbow coming out of the inlet of the spraying tube.

Figure 37

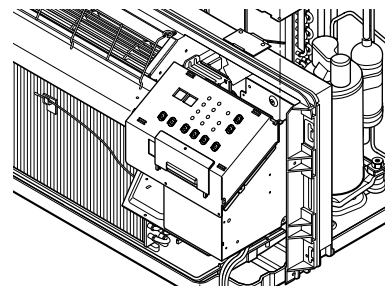
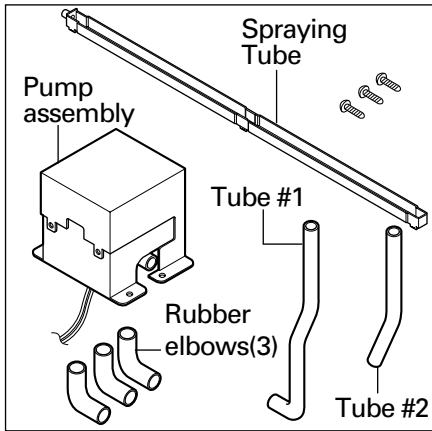

Figure 38



15. Assembly the unit back following the reverse order of disassembly.

NOTE: All tube should be inserted into rubber elbows by at least 1/2 inch

Figure 40

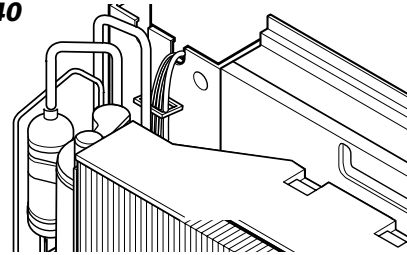

14. Connect the condensate pump to the ICR relay of the terminal of the board as shown in fig 39. Make sure to fasten the pump wire through the wire clip on the back side of the control barrier as shown in fig. 40

Figure 39

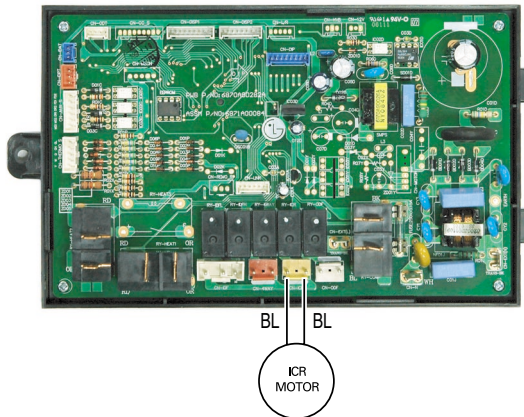

Architecture Grille Aluminum - Single Pack

Part No: AYAGALA01

Stamped Aluminum Grille

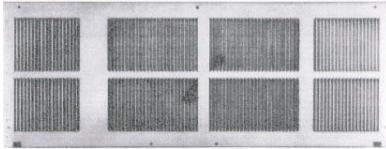

Architecture Grille



Description

Outdoor grilles are attached to the wall sleeve and exposed to the exterior wall. The grilles are an industry standard size of 42" x 16".

Receiving

Upon receipt of the product, inspect the shipping carton for signs of visible damage. Report any damage or shortage to the carrier and note it on the delivery receipt. The unit must be stored in its original shipping carton in a dry, secure place prior to its installation and use.

Installation

The installation and servicing of the equipment referred to in this booklet should be performed by qualified, experienced technicians.

WARNING

Hazardous Voltage!

Disconnect all electric power, including remote disconnects before servicing. Follow proper lockout/tagout procedures to ensure the power can not be inadvertently energized. Failure to disconnect power before servicing could result in death or serious injury.

Important Note:

The unit OFF switch does not disconnect all electrical power to this unit.

Note:

A baffle kit must not be used with a stamped aluminum grille on any PTAC installation.

Stamped Aluminum Grille

1. Prepare the wall sleeve for installation of the grille by removing the cardboard stiffener and rear enclosure panel from the sleeve. These items may be removed from inside of the building.

Note:

The sleeve stiffener must be taken out before the rear sleeve enclosure panel can be removed from the sleeve.

2. Prepare the stamped aluminum grille for installation on the sleeve by inserting the six (6) plastic grommets into the square holes located near the outer edges of all four sides of the grille. With the grille positioned so the flanges of all four sides are in the up position, insert the grommets so the square end protrudes through the grille in the opposite direction from the flanges.
3. Turn the grille so it can be removed through the rear sleeve opening.
4. Install the stamped aluminum grille by aligning the guide pins located in the lower right and left hand corners of the grille with the corresponding holes in the rear of the wall sleeve.
5. Secure the grille by threading each of the screws into the plastic grommets.
6. Remove the wire handle (not shown in the picture) from the center of the grille prior to installing the chassis into the sleeve.

Note:

Be sure to keep a firm grip on wire handle and grille to prevent it from dropping and/or causing possible injury or property damage.

Architectural Grille

1. Remove the cardboard sleeve stiffener and the rear enclosure of the sleeve as described in Step 1 of the stamped aluminum grille instructions.
2. Turn the grille so it can be removed through the rear sleeve opening.
3. Install the grille by aligning the four screws supplied to their corresponding holes in the architectural grille.

4. Secure the grille to the sleeve by tightening the four screws to their corresponding holes in the grille.
5. Remove the wire handle after the installation is complete.

Note:

The stamped aluminum grille includes 6 screws, washers, nuts, and plastic grommets. The architectural grille includes 4 screws.

Condensate Drain kit

Part No: AYDR101

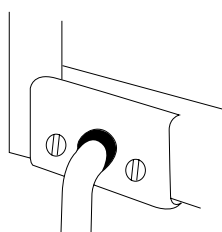

Description

Condensate water will drain from the chassis into the sleeve during normal heat pump operation. This can also occur during times of high humidity when in cooling operation. Install either the outdoor or indoor drain kit components to control the condensate water where normal drainage from the wall sleeve is not possible or undesirable. See Figure 35 for all components of the drain kit.

⚠ WARNING

Hazardous Voltage!

Disconnect all electric power, including remote disconnects before servicing. Follow proper lockout/ tagout procedures to ensure the power can not be inadvertently energized. Failure to disconnect power before servicing could result in death or serious injury.

Important Note:

The unit OFF switch does not disconnect all electrical power to this unit.

Receiving

Upon receipt of the product, inspect the shipping carton for signs of visible damage. Report any damage or shortage to the carrier and note it on the delivery receipt. The product must be stored in its original shipping carton in a dry, secure place prior to its installation and use.

Installation

The installation and servicing of the equipment referred to in this booklet should be performed by qualified, experienced technicians.

Figure 42 – Components of Drain Kits

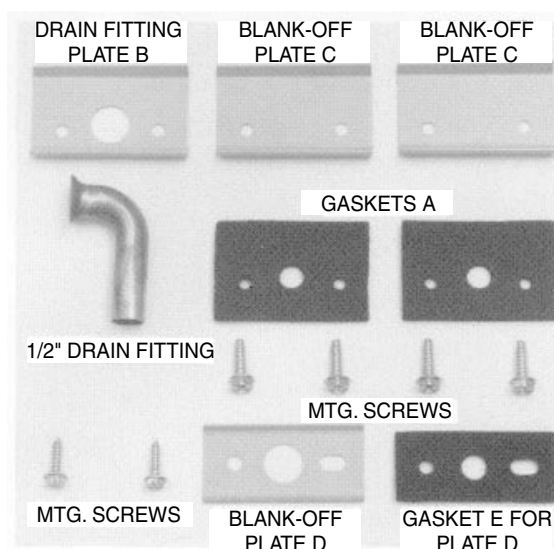

Drain Installation

Note:

The optional drain kit serves only as a link between the unit and field-supplied condensate drain system. Installing the kit without connecting it to a drainage system will result in inadequate condensate removal, possible leakage and corrosion.

Algaecide: Some algaecide products may cause damage to the unit basepan and therefore should not be used. Contact your sales representative when considering the use of a commercial algaecide. See Figure 42 for components of the drain kit.

Figure 36 – Outdoor Drain Kit Installation

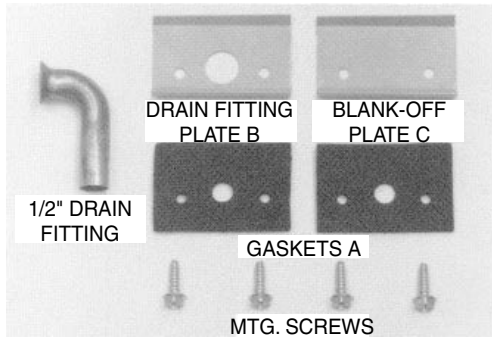

Outdoor Drain Kit Installation

Before installing the wall sleeve louvered condenser grille, it must be determined if the optional outdoor wall sleeve drain kit is to be installed. The drain kit will allow the condensate from the outdoor and indoor coils to be routed to a suitable area. The drain kit can be installed so the condensate can be drained from the right or left hand side of the wall sleeve. See Figure 36. See local codes for proper condensate disposal.

To install the outdoor drain components proceed as follows:

1. Remove the rear enclosure panel and the sleeve stiffener. These items may be removed from the inside of the building.
2. The drain fitting can be installed on the left or right hand side of the sleeve. (Illustration will be for a right hand installation.) Insert the drain fitting in the opening of gasket A and hole of plate B. Secure this assembly to the rear of the sleeve with two sheet metal screws into holes G provided in sleeve. See Figures 43 and 44.
3. Locate the other gasket A on the back of blank off plate C and secure the assembly to the left rear of wall sleeve with sheet metal screws provided. See Figure 45 for finished left hand side installation.

If the unit chassis is to be installed right away, install the condenser grille to wall sleeve with hardware provided. See condenser grille installation instructions.

If the unit chassis will not be installed right away, replace the rear enclosure panel in the wall sleeve. This will help protect the inside of the building from weather damage.

If a subbase is used, be sure the right hand subbase cover is removed before the chassis is installed in the sleeve. Slide the chassis into the wall sleeve until the chassis flanges

contact the front edge of sleeve. Secure the chassis to the wall sleeve on each side with screws provided.

Re-install the cabinet front.

See the following pages for installation instructions of indoor drain kit.

Figure 43

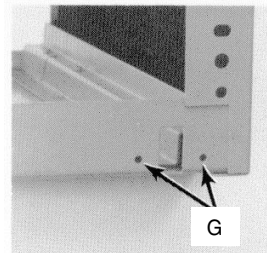

Figure 44

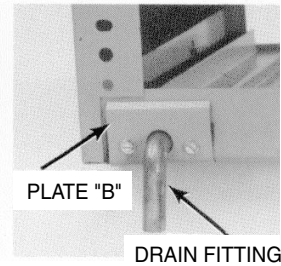

Figure 45

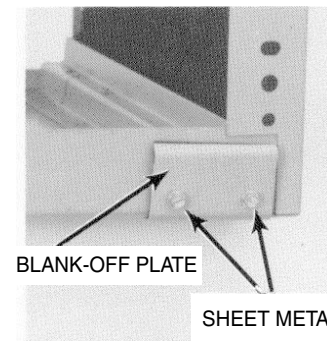
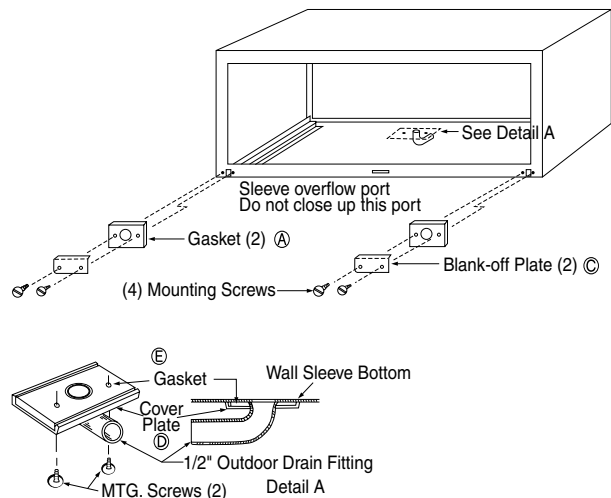

Figure 46



Indoor Drain Kit Installation

The internal drain is installed on the bottom of the wall sleeve when it is required to drain the condensate into a drain system inside of the building.

The components of the wall sleeve drain kit are shown in Detail A. Use components C (2), D, E, mounting screws (6) and the Outdoor drain fitting.

1. The components D, E, and drain fitting of the kit are mounted on the bottom of the wall sleeve prior to the installation of the sleeve. It may be located in a feasible area on the bottom of the sleeve which is inside of the room except when a subbase is used. When a subbase is installed, the drain may be a minimum of 3 1/2 " from the front flange of the wall sleeve. The minimum clearance should provide adequate clearance for the subbase, see Figures 46 and 47.
2. Cut out the template in the lower right hand corner of these instructions to locate the field drilled holes. (Two to mount the plate and one for the Outdoor drain fitting). See Detail A on how the components have to be installed after the holes are drilled in the bottom of the wall sleeve. If the drain fitting is not connected to an indoor drainage system immediately after the wall sleeve is installed, it must be plugged with a cork to prevent indoor water damage in case it rains.

An indoor tube or hose (furnished by others) must be installed on the drain fitting and interconnected to the drain system inside of the building.

Install the two blank-off plates C and gaskets A on the outdoor portion of the wall sleeve as shown in Figure 40. These components may be installed after the sleeve is secured in the wall opening just prior to the installation of the condenser grille and chassis.

Figure 47

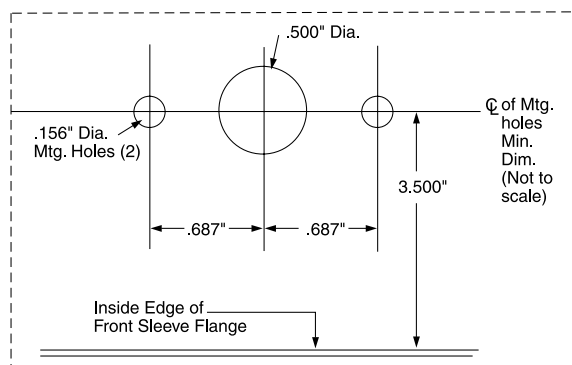

Leveling Legs

Part No: AYLL101

Description

Leveling legs are designed to provide extra front support and leveling of the wall sleeve. Two leg assemblies are required per unit and are provided in each kit. Four screws are also provided with each kit for attachment to the wall sleeve. See Figure 46.

The leveling legs must be installed before the chassis is installed, but after the wall sleeve is in place. Holes must be drilled in each side of the wall sleeve, below the duct package holes, for attachment to the wall sleeve.

Receiving

- Compare kit identification number with sales order to ensure that the correct kit has been received.
- Inspect the leveling legs for shipping damage. File damage claims with the delivering carrier immediately.

Installation

The installation and servicing of this equipment should be performed by qualified, experienced technicians.

WARNING

Hazardous Voltage!

Disconnect all electric power, including remote disconnects before servicing. Follow proper lockout/tagout procedures to ensure the power can not be inadvertently energized. Failure to disconnect power before servicing could result in death or serious injury.

Important Note:

The unit OFF switch does not disconnect all electrical power to this unit.

Checklist

The following is an abbreviated guide to leveling leg installation. Refer to appropriate areas for more detailed information.

Leveling Leg Assembly

To install the leveling leg assembly, complete the following:

1. Drill two 1/8-inch holes in each side of the wall sleeve, as shown in Figure 48, using the leveling leg assembly as a template. Locations near the front of the sleeve provide more support.
2. Adjust the leveling legs to the approximate height needed and install them on either side of the wall sleeve, using the screws provided. Bottom of wall sleeve can be anywhere from three to five inches above the screw base. Caulk around screws to prevent water leaks.
3. Level the sleeve horizontally from side-to-side. Provide a slight slope (one-quarter bubble in the sight glass) toward the outside. Check the level again after the unit has been installed. Adjust the legs as needed.

Figure 48 - Leveling Leg Assembly

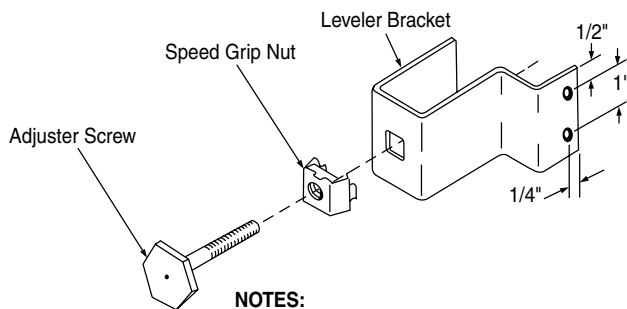

NOTES:

1. Two leveling legs are supplied in each kit.
2. One kit is required per unit.
3. Four mounting screws are provided in each kit.

Installation on Wall Sleeve

1. Drill four 1/8-inch diameter holes in the wall sleeve, two on each side, using the leveling legs as a template. Caulk around screws to prevent water leaks.
2. Attach the legs to the wall sleeve, using the screws provided.
3. Adjust the leveling legs to level the wall sleeve from side to side and provide a slight pitch to the outside (one-quarter bubble in sight glass).

Figure 49 - Leveling Leg Installation on Wall Sleeve

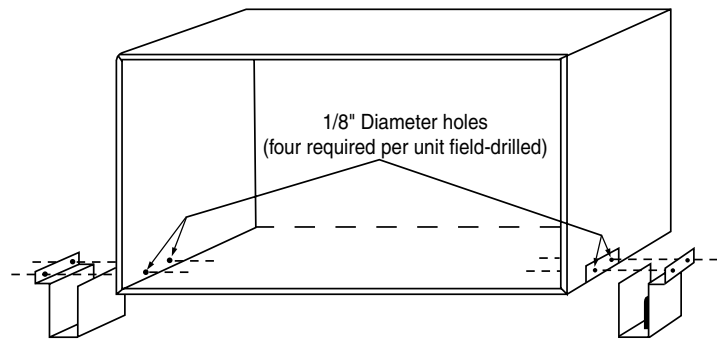

Hard Wire Kit

Part No: AYAGALA01



Description

Hard Wire Junction Box (Direct Wire Sub-Base) The hard wire junction box kit is used to hard wire the unit when it is not desirable to use the standard unit subbase or the unit power cord.

The junction box provides a protected enclosure for electrical connections as required by some electrical codes.

The hard wire junction box is intended to be mounted on the floor or the adjacent wall.

The junction box is furnished with approximately 2-1/2 feet of 1/2-inch flexible steel conduit and a metal box for securing the conduit to the unit cabinet at the incoming power opening.

An optional 230/208V or 265V power switch assembly is available for use with the hard wire junction box or subbase. The switch provides a POWER ON/OFF function at the unit as required by some electrical codes.

A replacement junction box cover plate is provided with each switch kit.

For additional information, refer to the Power Switch Installation Instructions.

Receiving

Upon receipt of the product, inspect the shipping carton for signs of visible damage. Report any damage or shortage to the carrier and note it on the delivery receipt. Unit must be stored in its original shipping carton in a dry, secure place prior to its installation and use.

Installation

The installation and servicing of this equipment should be performed by qualified, experienced technicians.

Junction Box Kit Installation and Wiring Procedure

Electrical connections at the unit must be made after the unit chassis is installed in the wall sleeve. The installer must determine and supply the mounting components for attaching the junction box to the wall or door.

WARNING

Hazardous Voltage!

Disconnect all electric power, including remote disconnects before servicing. Follow proper lockout/tagout procedures to ensure the power can not be inadvertently energized. Failure to disconnect power before servicing could result in death or serious injury.

Important Note:

The unit OFF switch does not disconnect all electrical power to this unit.

CAUTION

Use Copper Conductors Only!

Unit terminals are not designed to accept other types of conductors. Failure to use copper conductors may result in equipment damage.

Important Note:

All wiring must comply with applicable local and national codes. Types and location of disconnect switches must comply with all applicable codes.

1. Remove the cover plate from the junction box
2. Mount the junction box to the wall or floor within 28 inches (711 mm) of the lower right corner of the wall sleeve.
3. If a disconnect switch is to be used, make electrical connections to it and mount the switch in the junction box. Refer to the Power Switch Installation Instructions.
4. Remove control panel assembly by removing the two screws holding control panel in place. Rotate the panel forward.
5. Disconnect the power cord leads from all electrical connections including the ground wire.
6. Remove the power cord clamp and the power cord from the unit.
7. For 208/230-volt units, remove and discard the white lead from the wire assembly. For 265-volt units, remove and discard the red lead from the wire assembly.
8. Remove the retaining ring from the threaded portion of the straight conduit clamp. Insert the three wires into the metal box through one of the two openings in the box. Replace the hole cover grommet into the unused hole to prevent objects from entering the box.
9. Replace the retaining ring back on the conduit clamp inside the metal box and tighten the ring securely.
10. Insert the three wires extending from the metal box into the incoming power opening on the unit so that approximately 20 inches (508 mm) of the wires protrude through the opening.
11. Attach the metal box to the chassis with the two screws provided. See Figure 50.
12. Insert the wire tie into the 1/4-inch diameter hole located just above the incoming power opening. Tie all wires together securely with the wire tie. See Figure 51.

208/230 Volt Units

1. Remove and discard the white lead from the wire assembly.
2. Connect the black lead to the line 2 terminal on the control board.
3. Connect the red lead to the common (C) terminal on the capacitor.
4. Connect the ground wire to the partition panel where the ground wire on the power cord was located. Use the supplied green ground screw.
5. Connect the red lead in the wire assembly at the junction box to the red lead of the field power source.
6. Connect the black lead in the wire assembly at the junction box to the black lead of the field power source.
7. Connect the ground wire of the field power source to the ground wire of the wire assembly at the junction box.
8. Install the junction box cover plate.
9. Reinstall the control panel assembly.

Figure 50 - Mounting Hard Wire Junction Box Kit

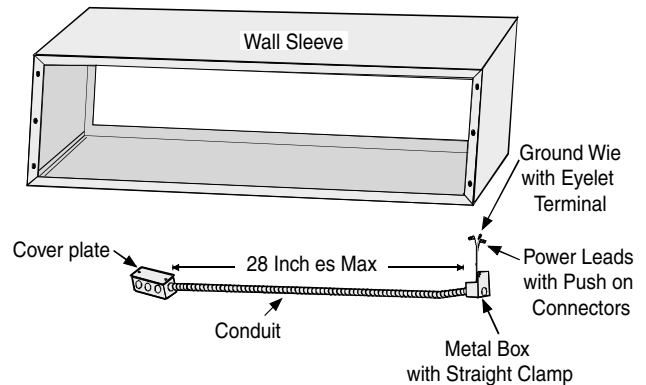

Figure 51 - Metal Box Location

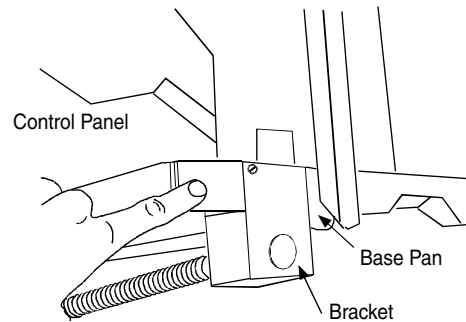
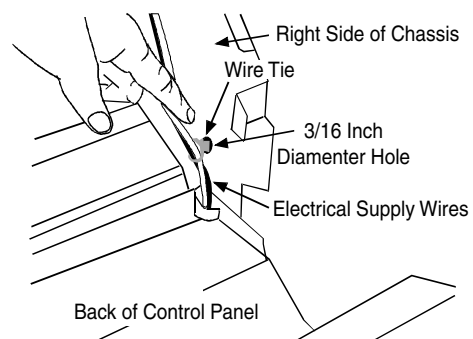
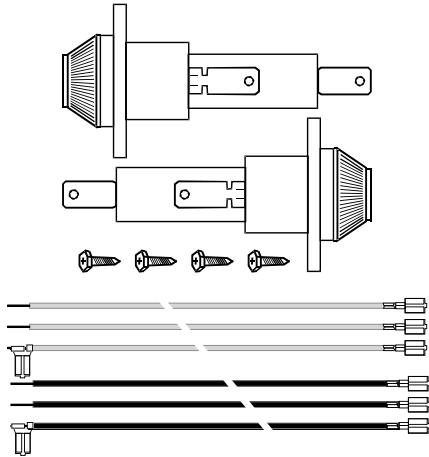

Figure 52 - Electrical Wiring Routing



Fuse Holder Kit

Part No: AYFH1101



Description

This optional fuse holder kit can be installed directly in the chassis or in the optional subbase. Fuse holder kits are available in 230/ 208 volt ratings. The installer should supply time delay fuses at 15, 20, 25, or 30 amps in accordance with the Maximum Overcurrent Protection as listed on the unit nameplate. Fuses may be purchased from the parts department.

Note:

The installation and servicing of this equipment must be performed by qualified, experienced technicians only.

WARNING

Hazardous Voltage!

Disconnect all electric power, including remote disconnects before servicing. Follow proper lockout/ tagout procedures to ensure the power can not be inadvertently energized. Failure to disconnect power before servicing could result in death or serious injury.

Important Note:

The unit OFF switch does not disconnect all electrical power to this unit.

CAUTION

Use Copper Conductors Only!

Unit terminals are not designed to accept other types of conductors. Failure to use copper conductors may result in equipment damage.

Important Note:

All wiring must comply with applicable local and national codes.

Type and location of fused disconnect switch(es) must comply with all applicable codes. Failure to follow these codes could result in overheating and equipment failure.

Receiving

Upon receipt of the product, inspect the shipping carton for signs of visible damage. Report any damage or shortage to the carrier and note it on the delivery receipt. Unit must be stored in its original shipping carton in a dry, secure place prior to its installation and use.

Installation

The installation and servicing of the equipment referred to in this booklet should be performed by qualified, experienced technicians.

Fuse Holder Kit Installation (Without Subbase)

1. Remove front by rotating bottom outward and then lifting up and out from chassis.

Figure 48 - Control Panel

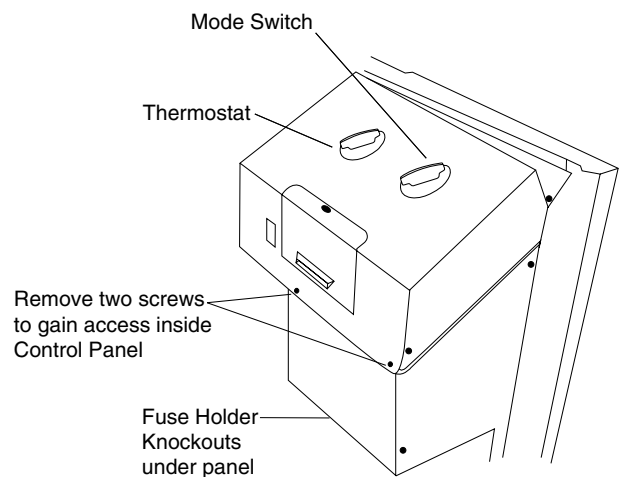

- To gain access inside the control panel, after removing the knobs and escutcheon, remove the screws holding panel in position.
Tilt control panel forward, being careful not to pinch any wires. (Figure 48)
- As viewed from the front, remove both knockouts on the control panel.
- Insert two fuse holders from the front. The fuse holders should be oriented so the quick-connect tabs are toward the center of the unit. Attach fuse holders using the screws and nuts provided. (Figure 48)
- Remove both power cord leads, one lead from the capacitor and one from the electronic board.
- Install one power cord lead on the center terminal of one fuse holder. (Figure 49)
- Install the remaining power cord lead on the center terminal of the second fuse holder. (Figure 49)
- Connect BK-10 wire from the side terminal of one fuse holder to the Line terminal on the electronic board. (Figure 48)
- Connect RD-10 wire from the side terminal of the other fuse holder to the common (C) terminal on the capacitor. (Figure 49)
- Tilt control panel back to original location, being careful not to pinch any wires. Align the control panel with the cover and screw panels into place with original screws. Replace escutcheon and control knobs.

Fuse Holder Kit Installation (With Subbase)

See previous section for installation in the control panel.

- Remove both knockouts at the fuse holder location. (Figure 50)
- Install the fuse holders using screws provided. The side connector tab on the fuse holders should be towards the left.
- Connect a stripped BK-9 wire to the center of the quick-connect tab of the fuse holders. Wire nut the other end of this wire to the black field connection wire (TB1). (Figure 51)
- Connect the other stripped BK-9 wire to the quick-connect tab on the side of the same fuse holder. Wire nut the other end to black subbase wire leading to receptacle. (Figure 51)

**Figure 49 - Fuse Holder Diagram
Control Panel Installation**

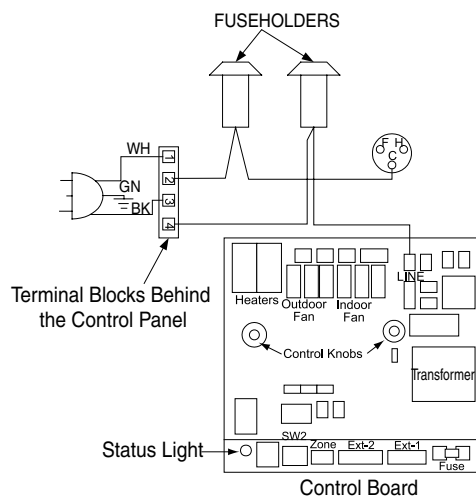

- Connect the stripped RD-9 wire to the center quick-connect tab of the second fuse holder. Wire nut the other end to the red field connection wire (TB3). (Figure 51)
- Connect the other stripped RD-9 wire to the quick-connect tab on the side of the second fuse holder. Wire nut other end to red subbase wire which leads to receptacle. (Figure 51)
- Insert time delay fuses into the fuse holders. Size all fuses by the Maximum Overcurrent Protection shown on the nameplate. Also refer to the serial plate on the unit.

Figure 50 - Subbase (Left Side)

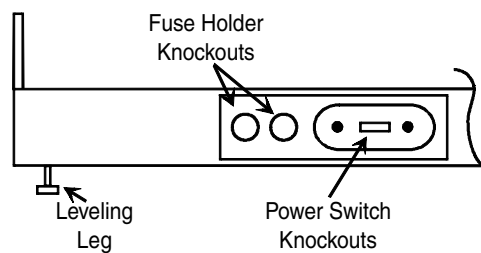
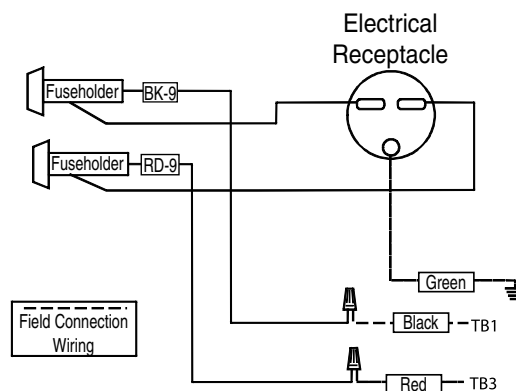
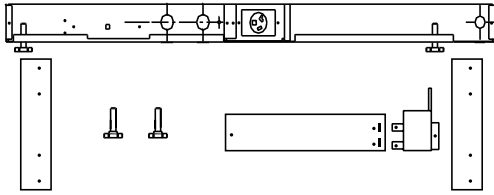

Figure 51 - Fuse Holder Diagram Subbase Installation



Subbase

Part No: AYSB1101 (230/208V 20A)
AYSB2101 (230/208V 30A)



Description

The subbase may be installed on the wall sleeve before or after installing the wall sleeve. The subbase is prewired. Electrical connections can be made on the left side after the access cover is removed. A grounding screw is provided.

Receiving

Upon receipt of the product, inspect the shipping carton for signs of visible damage. Report any damage or shortage to the carrier and note it on the delivery receipt. The unit must be stored in its original shipping carton in a dry, secure place prior to its installation and use.

Installation

The installation and servicing of the equipment referred to in this booklet should be performed by qualified, experienced technicians.

WARNING

Hazardous Voltage!

Disconnect all electric power, including remote disconnects before servicing. Follow proper lockout/ tagout procedures to ensure the power can not be inadvertently energized. Failure to disconnect power before servicing could result in death or serious injury.

Important Note:

The unit OFF switch does not disconnect all electrical power to this unit.

CAUTION

Use Copper Conductors Only!

Unit terminals are not designed to accept other types of conductors. Failure to use copper conductors may result in equipment damage.

Note:

When using a subbase, the wall sleeve must be installed a minimum of 3-1/4 inches (83 mm) above a finished floor and a minimum of 2-3/4 inches (70 mm) from a finished wall.

1. Remove parts B and C (Figure 54, next page) from the subbase and join together using two metal screws provided. This assembly now becomes the right front cover (Part F) of the subbase. (Figure 53, next page)
2. Position subbase under the front of the wall sleeve.
3. Align the back edge of the flange on cover A (Figure 54, next page) to front of the wall sleeve flange. (Figure 55, next page)
4. Drill four 1/8 inch holes in wall sleeve to line up with holes in subbase. (Figure 54, Location D, next page) Mount subbase to wall sleeve with four sheet metal screws provided with kit. (Figure 54, Location D, next page)
5. Remove the left front cover from the subbase. (Figure 54, Part A, next page)
6. Position skirting on each side of wall sleeve to prevent the entry of foreign materials. Trim skirting to desired length. Attach skirting with four sheet metal screws provided with kit. (Figure 54, Location E, next page)
7. Wire subbase for appropriate voltage (Figure 56, next page).

Note:

The proper subbase must be ordered to obtain the correct electrical receptacle. (Figure 57)

8. After wiring is complete, mount covers A and F to the subbase with provided screws. (Figure 54)
9. When installing optional accessories to the subbase, refer to each installation instruction for that accessory.

Figure 53

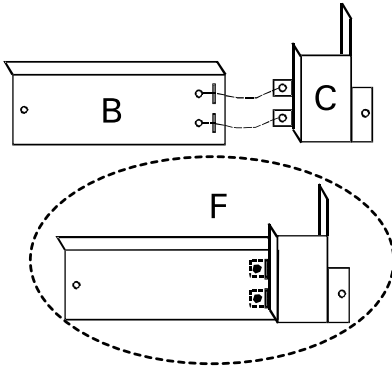

Figure 54 - Part/Location Identification

Part/Location Identification	
A	Left Front Cover
B	Right Front Cover
C	Front Cord Panel
D	Wall Sleeve Hole Location
E	Skirting Hole Location
F	Right Cover Assembly

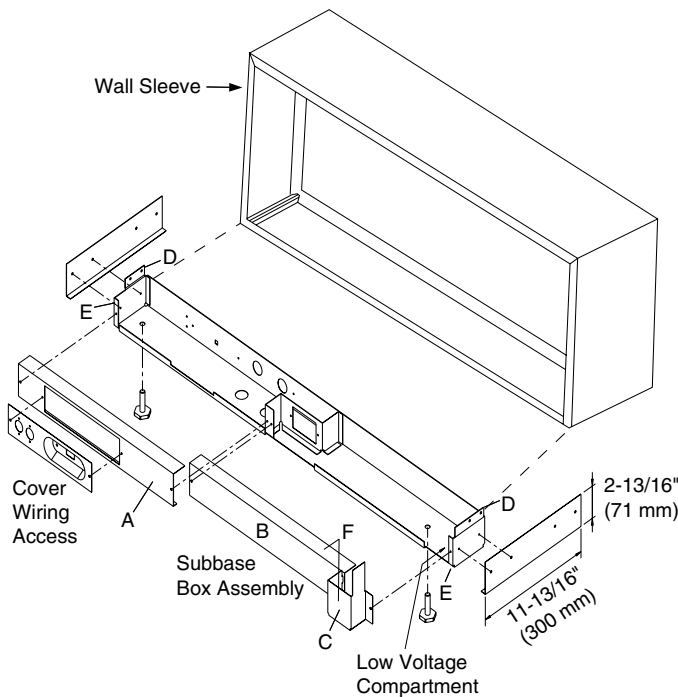

Figure 55 - Dimensions

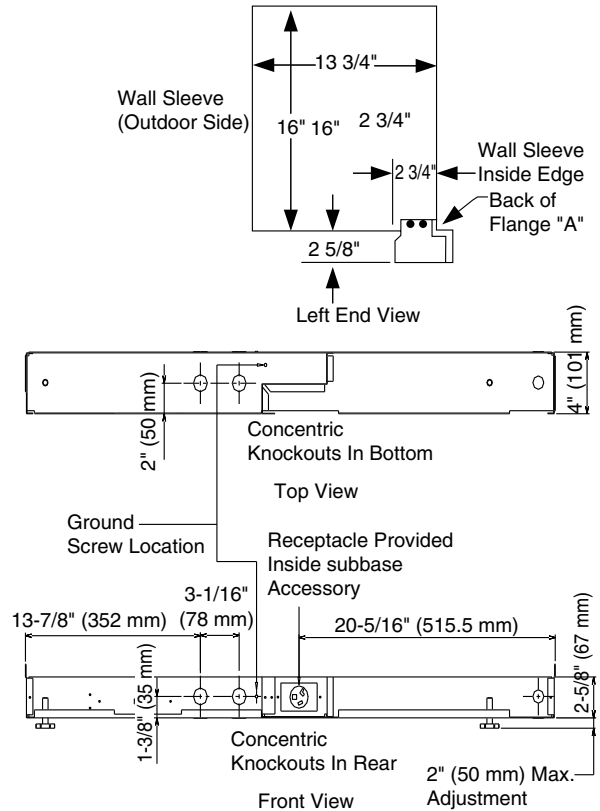

Figure 56 - Wiring Diagram

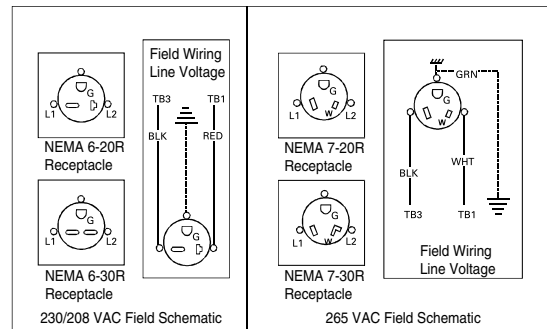
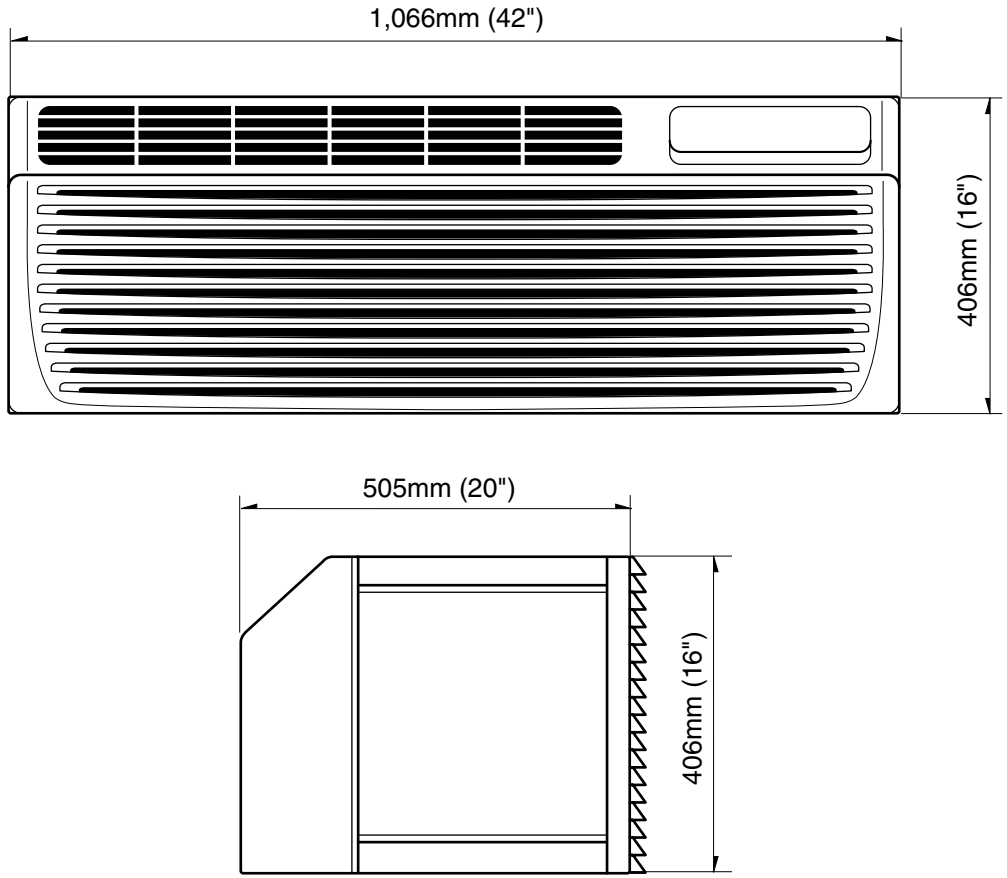

Figure 57 - NEMA Plug Configurations

Voltage	Unit Plug	Subbase Receptacle
230/208	NEMA6-15AMP	NEMA6-20AMP
265	NEMA7-20AMP	NEMA7-20AMP
230/208	NEMA6-20AMP	NEMA6-20AMP
265	NEMA7-20AMP	NEMA7-20AMP
230/208	NEMA6-30AMP	NEMA6-30AMP
265	NEMA7-30AMP	NEMA7-30AMP

5. Troubleshooting guide

5.1 OUTSIDE DIMENSIONS



5.2 PIPING SYSTEM

Following is a brief description of the important components and their functions in the refrigeration system. Refer to Figure 61 to follow the refrigeration cycle and the flow of the refrigerant in the cooling cycle.

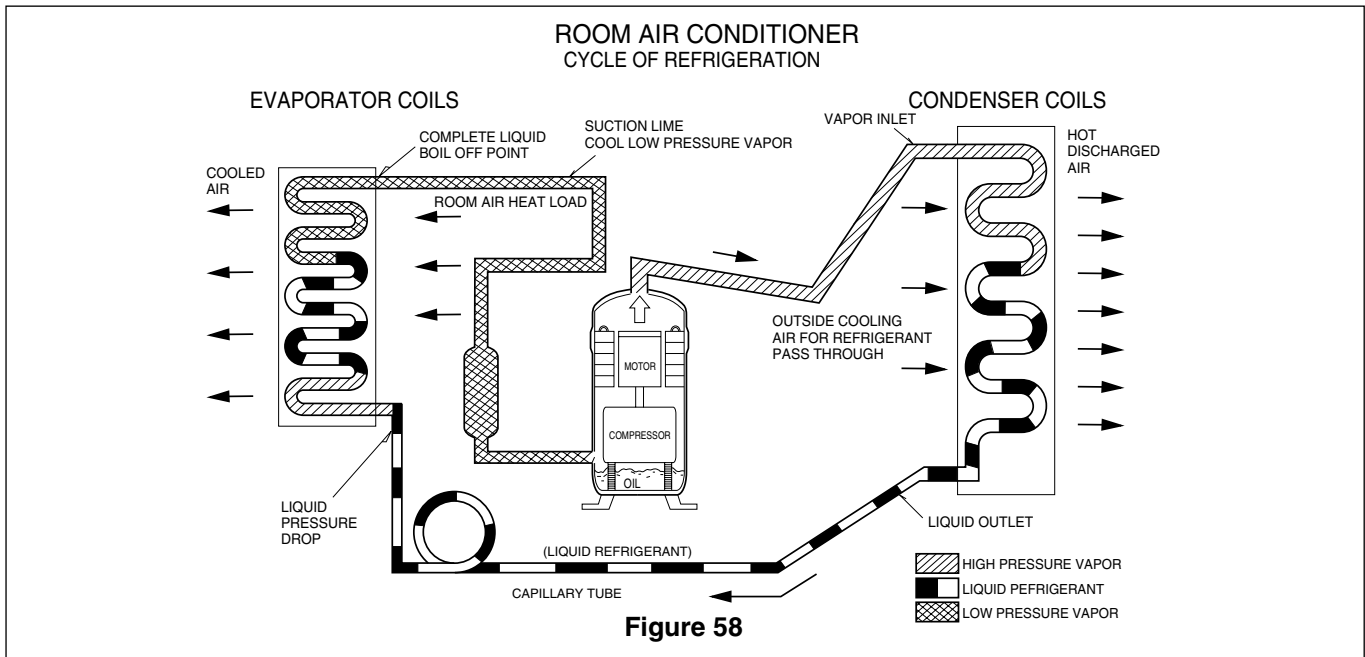

5.3 TROUBLESHOOTING GUIDE

In general, possible trouble is classified in two causes.

The one is Starting Failure which is caused from an electrical defect, and the other is Ineffective Air Conditioning caused by a defect in the refrigeration circuit and improper application.

Unit is running but cooling is ineffective

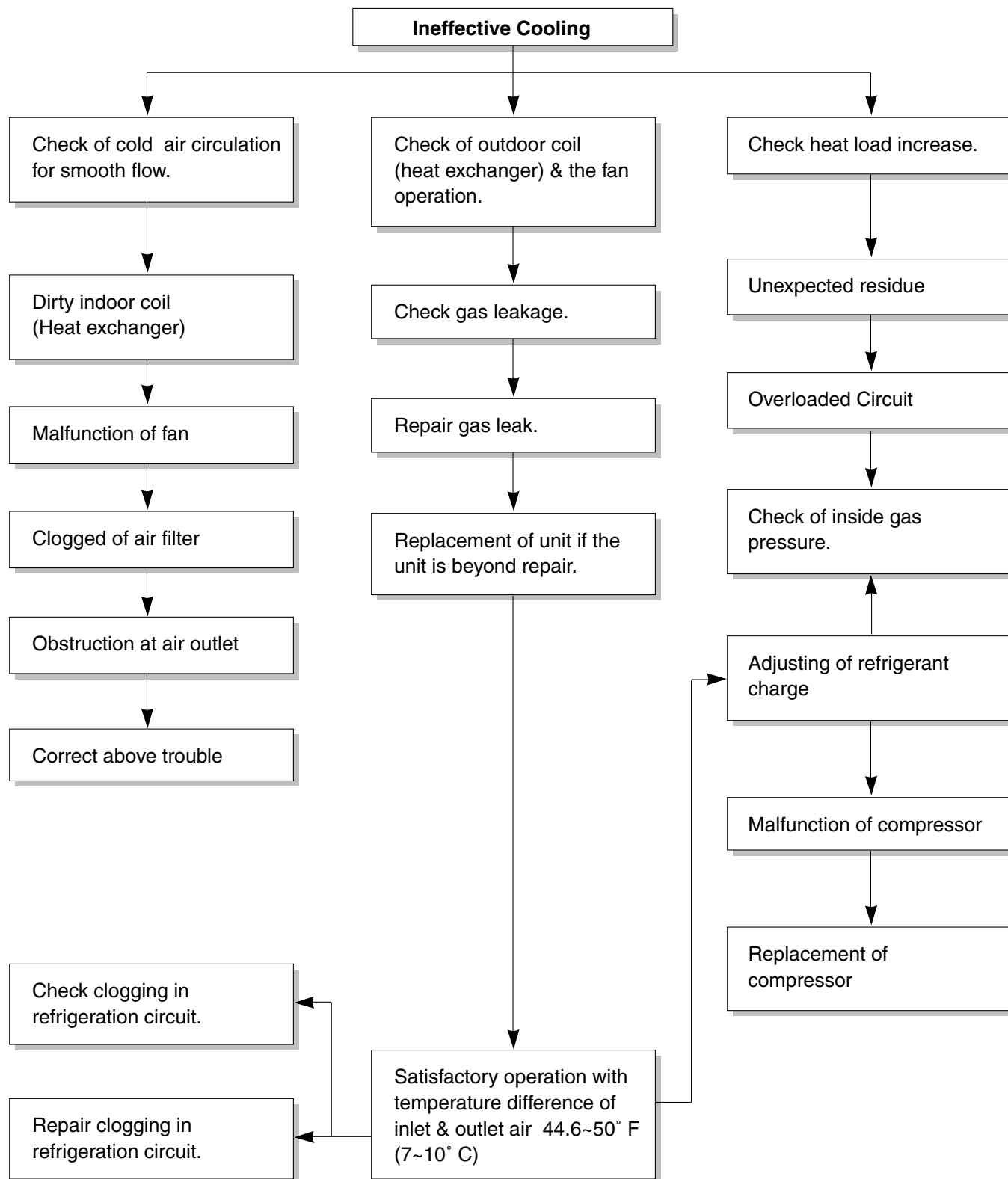

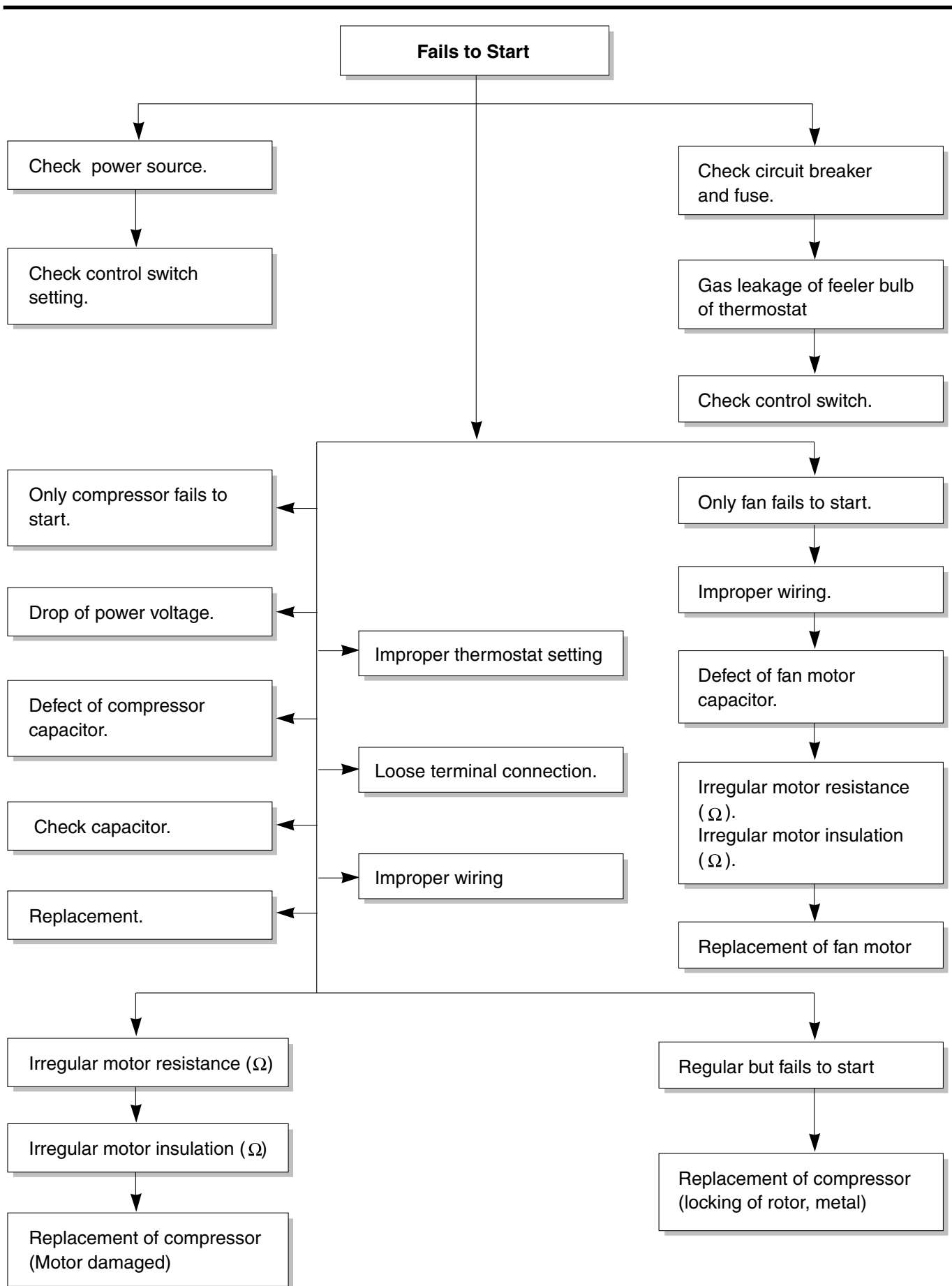

COMPLAINT	CAUSE	REMEDY
Fan motor will not run.	No power	Check voltage at outlet. Correct if none.
	Power supply cord	Check voltage to rotary switch. If none, check power supply cord. Replace cord if circuit is open.
	Rotary switch	Check switch continuity. Refer to wiring diagram for terminal identification. Replace switch if defective.
	Wire disconnected or connection loose	Connect wire. Refer to wiring diagram for terminal identification. Repair or replace loose terminal.
	Capacitor (Discharge capacitor before testing.)	Test capacitor. Replace if not within $\pm 10\%$ of manufacturer's rating. Replace if shorted, open, or damaged.
	Will not rotate	Fan blade hitting shroud or cross flow fan hitting scroll. Realign assembly. Units using slinger ring condenser fans must have $\frac{1}{4}$ to $\frac{5}{16}$ inch clearance to the base. If it is hitting the base, shim up the bottom of the fan motor with mounting screw(s). Check fan motor bearings; if motor shaft will not rotate, replace the motor.
Fan motor runs intermittently	Revolves on overload.	Check voltage. See limits on this page. If not within limits, call an electrician. Test capacitor. Check bearings. Does the fan blade rotate freely? If not, replace fan motor. Pay attention to any change from high speed to low speed. If the speed does not change, replace the motor.
Fan motor noise.	Grommets	Check grommets; if worn or missing, replace them.
	Fan	If cracked, out of balance, or partially missing, replace it.
	Turbo fan	If cracked, out of balance, or partially missing, replace it.
	Loose set screw	Tighten it.
	Worn bearings	If knocking sounds continue when running or loose, replace the motor. If the motor hums or noise appears to be internal while running, replace motor.

COMPLAINT	CAUSE	REMEDY
Compressor will not run, but fan motor runs.	Voltage	Check voltage. See the limits on the preceding page. If not within limits, call an electrician.
	Wiring	Check the wire connections, if loose, repair or replace the terminal. If wires are off, refer to wiring diagram for identification, and replace. Check wire locations. If not per wiring diagram, correct.
	Rotary	Check for continuity, refer to the wiring diagram for terminal identification. Replace the switch if circuit is open.
	Thermostat	Check the TEMP control. If not at the lowest number set TEMP control to this setting and restart the unit. Check the continuity of the thermistor. Replace the thermistor if the circuit is open.
	Capacitor (Discharge capacitor before servicing.)	Check the capacitor. Replace if not within $\pm 10\%$ of manufacturers rating. Replace if shorted, open, or damaged.
	Compressor	Check the compressor for open circuit or ground. If open or grounded, replace the compressor.
	Overload	Check the compressor overload, if externally mounted. Replace if open. (If the compressor temperature is high, remove the overload, cool it, and retest.)

ROOM AIR CONDITIONER VOLTAGE LIMITS

NAME PLATE RATING	MINIMUM	MAXIMUM
208/230V	187V	253V

COMPLAINT	CAUSE	REMEDY
Compressor cycles on overload.	Voltage	Check the voltage. See the limits on the preceding page. If not within limits, call an electrician.
	Overload	Check overload, if externally mounted. Replace if open. (If the compressor temperature is high, remove the overload, cool, and retest.)
	Fan motor	If not running, determine the cause. Replace if required.
	Condenser air flow restriction	Remove the cabinet. inspect the interior surface of the condenser; if restricted, clean carefully with a vacuum cleaner (do not damage fins) or brush. Clean the interior base before reassembling.
	Condenser fins (damaged)	If condenser fins are closed over a large area on the coil surface, head pressures will increase, causing the compressor to cycle. Straighten the fins or replace the coil.
	Capacitor	Test capacitor.
	Wiring	Check the terminals. If loose, repair or replace.
Insufficient cooling or heating	Refrigerating system	Check the system for restriction.
	Air filter	If restricted, clean or replace.
	Exhaust damper door	Close if open.
Excessive noise.	Unit undersized	Determine if the unit is properly sized for the area to be cooled.
	Cross flow fan	Check the set screw or clamp. If loose or missing, correct. If the blower or fan is hitting air guide, rearrange the air handling parts.
	Copper tubing	Carefully rearrange tubing not to contact, compressor, shroud, and barrier.

6. Piping Diagrams

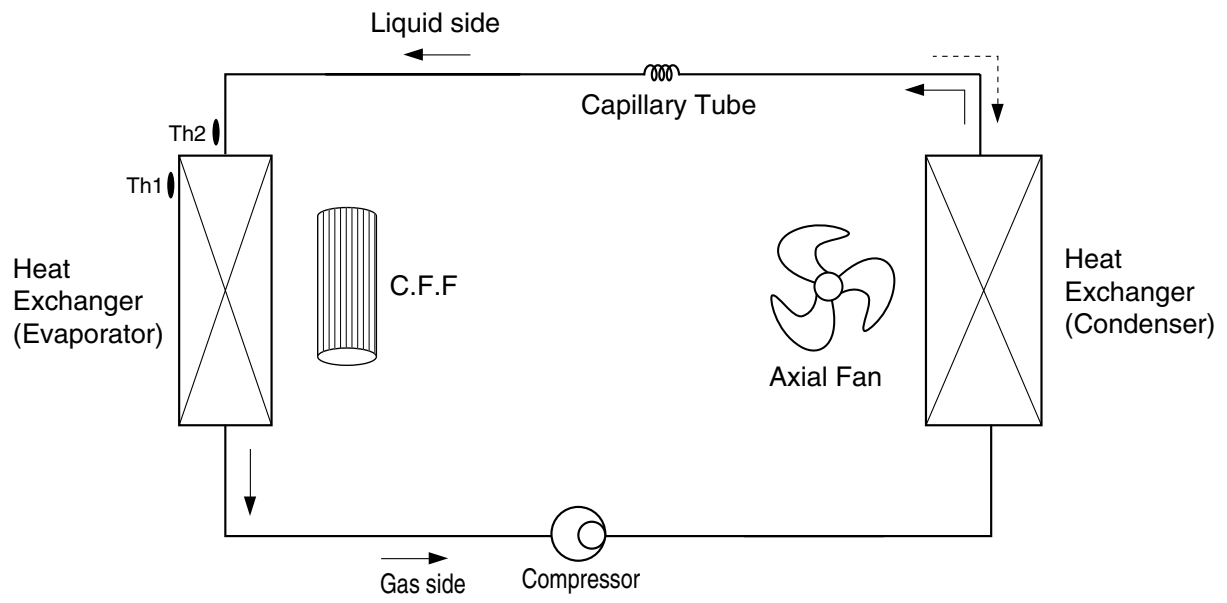

LOC.	Description	PCB Connector
Th1	Thermistor for indoor Air temperature	CN-IDAT
Th2	Thermistor for Evaporator Pipe temperature	CN-IDPT

7. Schematic diagram

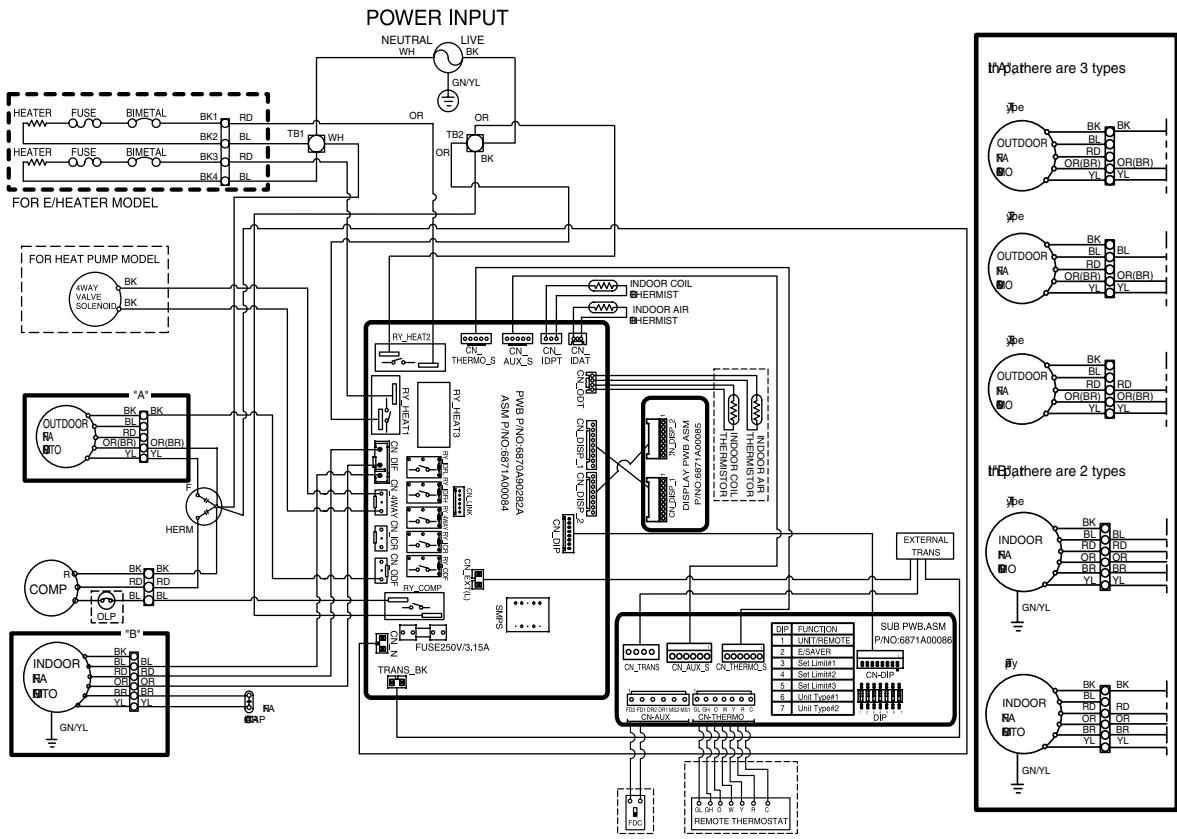

P/N:3850A20594H

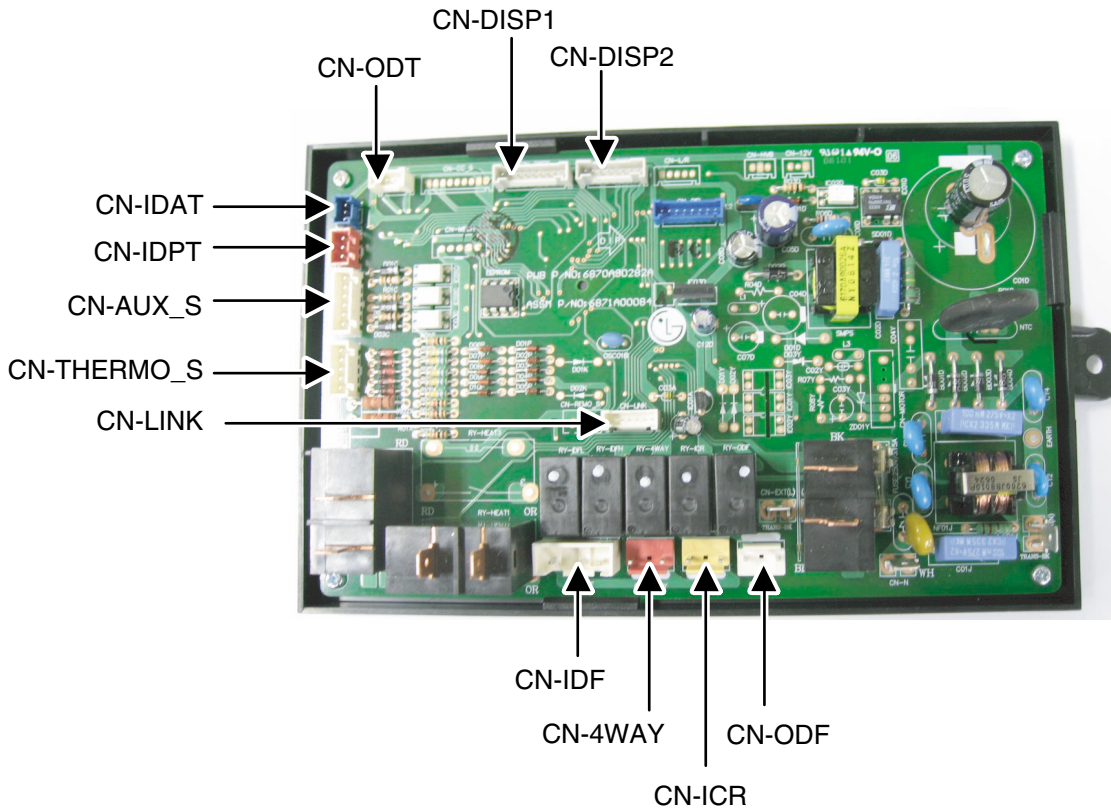

8. Exploded View

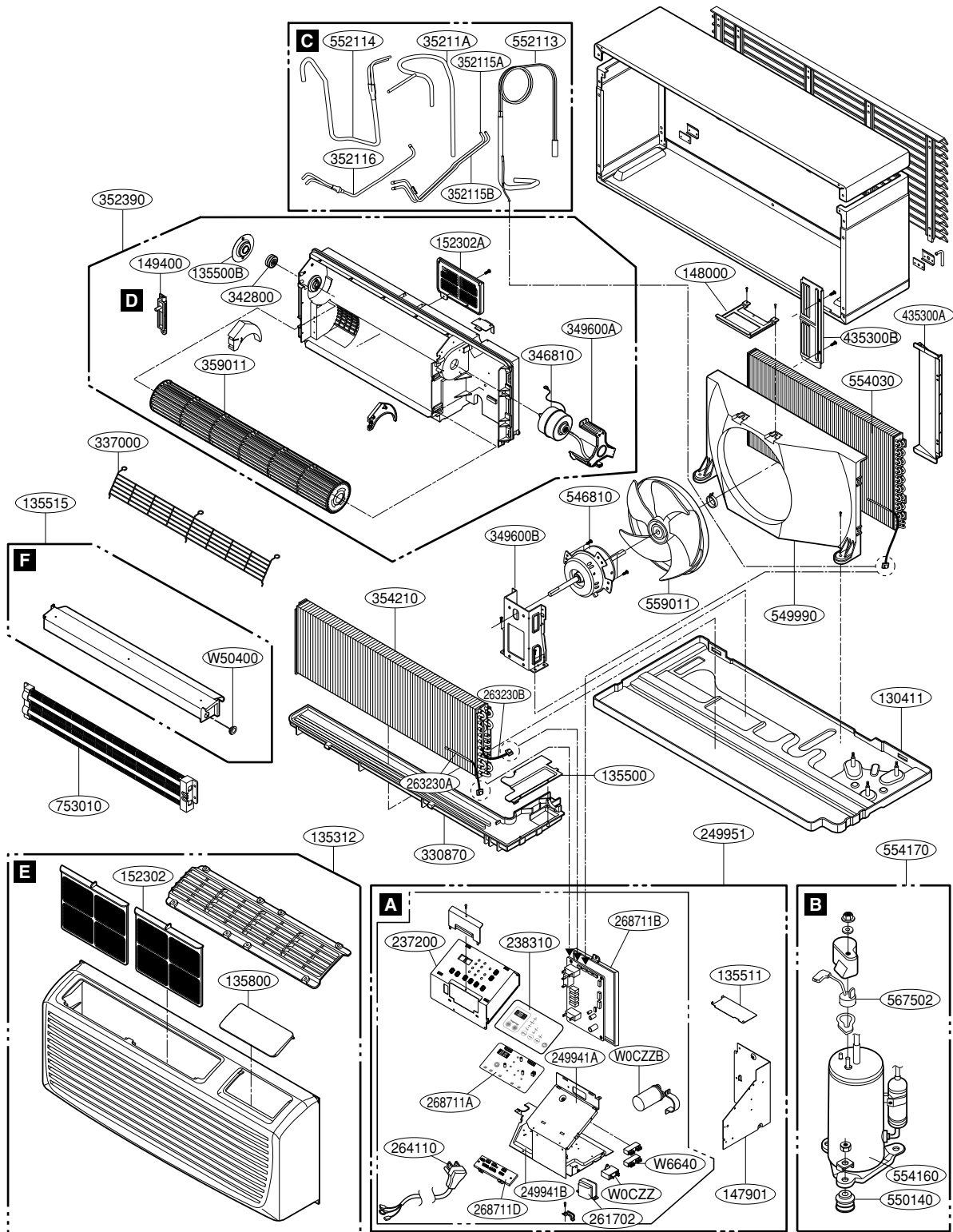

263230A	Thermistor for Indoor Air Temperature	Housing color : blue
263230B	Thermistor for Evaporator Pipe Temperature	Housing color : blue

Note) * Please ensure GCSC since the replacement parts may be changed depending upon the buyer's request.
 Please check the correct parts in View RPL(Replacement Part List) on GCSC.
 (GCSC Website <http://biz.lgservice.com>)



P/NO : MFL42137105

February, 2008