

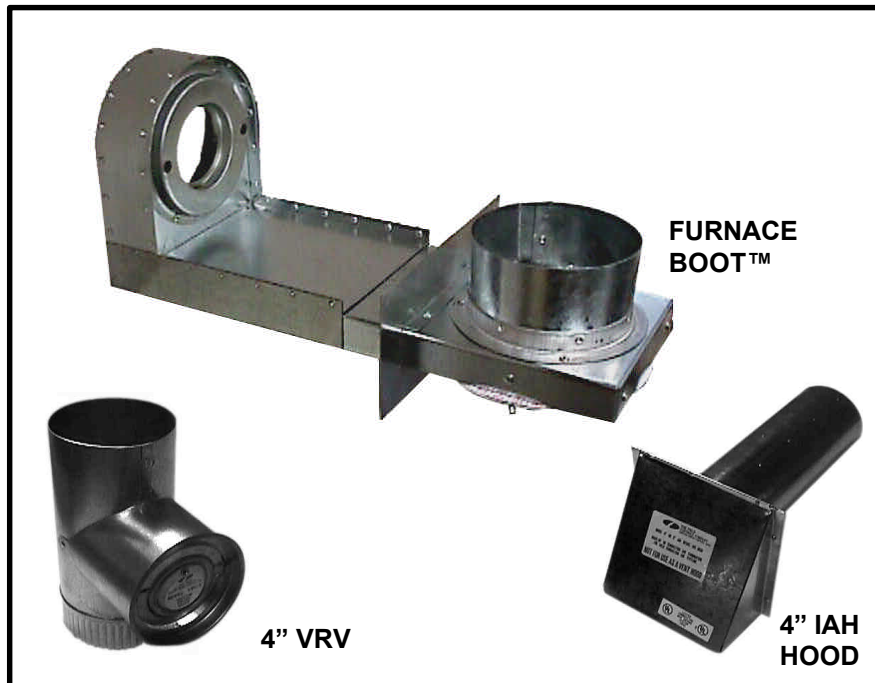

COMBUSTION AIR SYSTEM

Model: CAS-2B-90E Furnace Boot™



This product is designed for use on the Beckett AFG burners, for the purpose of routing combustion air directly to the burner, with the added safety feature of the vacuum relief valve.

NOTE: For burner inputs up to 1.5 gph at 100 psi input pressure or equivalent.

"The Furnace Boot™ model CAS-2B-90E is for use only on the designated burner(s) as described in these instructions only when the specific burner includes this Furnace Boot™ when shipped from the burner manufacturer or where the burner instructions specifically reference the model CAS-2B-90E Furnace Boot™ as an optional air intake system."

ITEMS INCLUDED IN KIT:

- 1 - 90E Furnace Boot™
- 1 - Set of Gaskets
- 1 - 4" VRV
- 1 - 4" IAH Hood
- 1 - Burner Coupling Set
- 2 - Mounting Bolts

INSTALLER SUPPLIED ITEMS:

- Duct Piping and Elbows
- 90° Elbows;
- 1/4" NPT Female x 1/4" NPT Male for routing oil line



FIELDCONTROLS
THE VENTING SOLUTIONS COMPANY

2630 Airport Road • Kinston, NC 28504
Phone: 252-522-3031 • FAX: 252-522-0214
www.fieldcontrols.com

THE PURPOSE OF THE VACUUM RELIEF VALVE (VRV)

The Vacuum Relief Valve is a safety device to guard against combustion problems associated with directly connecting oil burners to the outside. Typical problems can be caused by blockage of the intake termination, icing up of the ductwork and effects of leeward side wind effects on a building.

VRV OPERATION

The VRV gate operates on changes in the vacuum pressure generated by the inlet to the oil burner. The VRV gate will remain closed during normal burner operation. During an abnormal operation (i.e., blockage of the intake or change in external building pressures) an increased negative pressure on the intake of the burner causes a reduction in burner airflow. Under this condition, the VRV gate opens, stabilizing and maintaining proper airflow to the burner. The VRV gate closes again once the abnormal condition is corrected.

INSTALLATION

1. Before the Furnace Boot™ can be mounted, a rectangular hole (2 1/2" X 6") must be located and cut into the side of the furnace cabinet. The hole is located from the center of the burner intake. (See Figure 1)
2. Remove the oil pump and air bands from the burner housing! Install the sealing gaskets onto the burner housing. (See Figure 2) Replace existing pump coupling with the coupling supplied with the Furnace Boot™. Position the Furnace Boot™ over intake on the burner housing. Align the holes in the Furnace Boot™ with the holes in the housing and re-attach the oil pump. (See Figure 3) **Note:** Replace pump coupling with the coupling supplied with kit. The Furnace Boot™ extension is mounted from the outside of the furnace cabinet and can be mounted to allow the routing of the duct pipe from the ceiling or from the floor. (See Figure 4) Assemble VRV balance weight onto the gate. Screw the weight all the way in. Then attach lock nut and knurl nut. (See Figure 4)

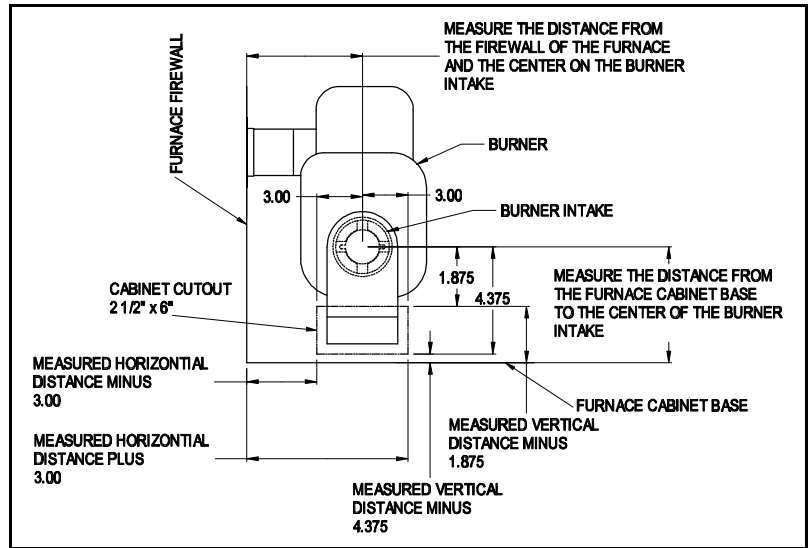

Figure 1

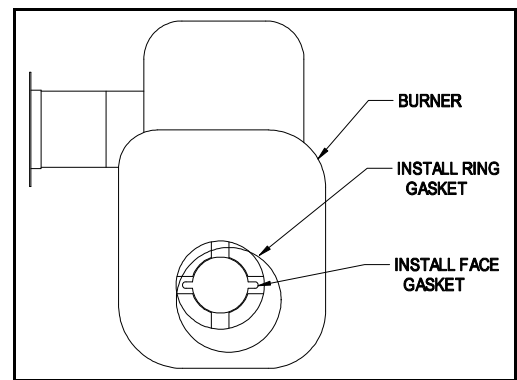

Figure 2

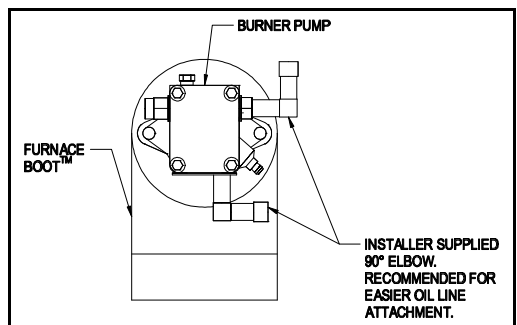

Figure 3

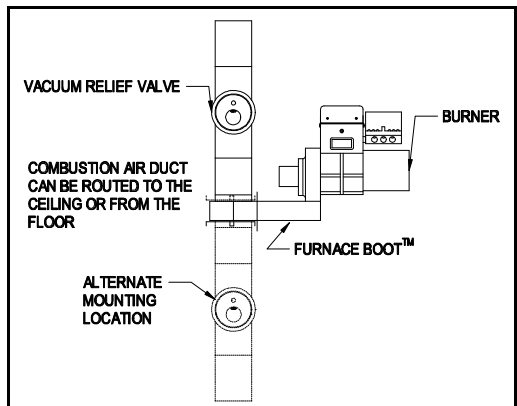

Figure 4

3. **For low firing rate applications with burner inputs up to .75 GPH only:**

- a. Insert flow restrictor pan in the inlet collar with the flat of the pan inward. (See Figure 5)
 - b. Push the pan as far as the pan can go. The pan will be approximately 5/8" from the air adjustment blades. (See Figure 6)
4. Mount VRV tee assembly or 90° elbow onto the Furnace Boot™ intake. Fasten using three (3) sheet metal screws on all joints. (See Figure 4)
 5. Assemble VRV balance weight onto the gate. Screw the weight all the way in. Then attach lock nut and knurl nut. (See Figure 7)
 6. Mount the VRV assembly onto the tee and fasten with a screw and nut in collar tabs. To ensure proper operation, check the gate for being level across the pivot points and plumb. (See Figure 8)
 7. Refer to Figure 9 for general installation layout.

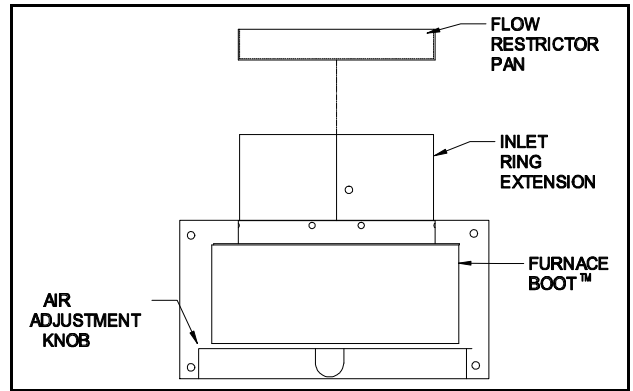

Figure 5

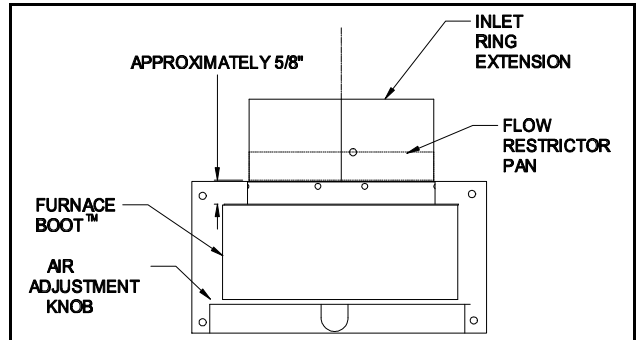

Figure 6

TERMINATION LOCATION GUIDELINES

1. Mount intake hood 12 inches above finished grade. If mounting on the side of a building prone to drifting snow, mount 12 inches above the snow line.
2. Mount at least 12 inches from either side of the vent termination and on the same wall if sidewall venting.
3. Always mount with the inlet vent termination opening pointing down.

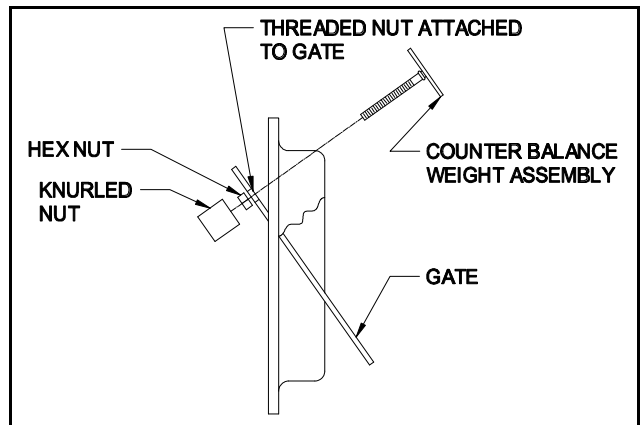

Figure 7

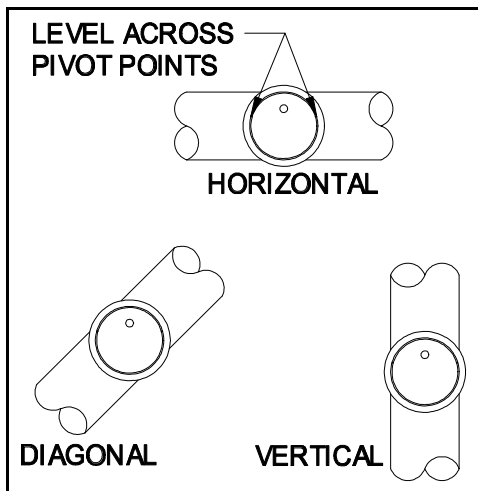

Figure 8

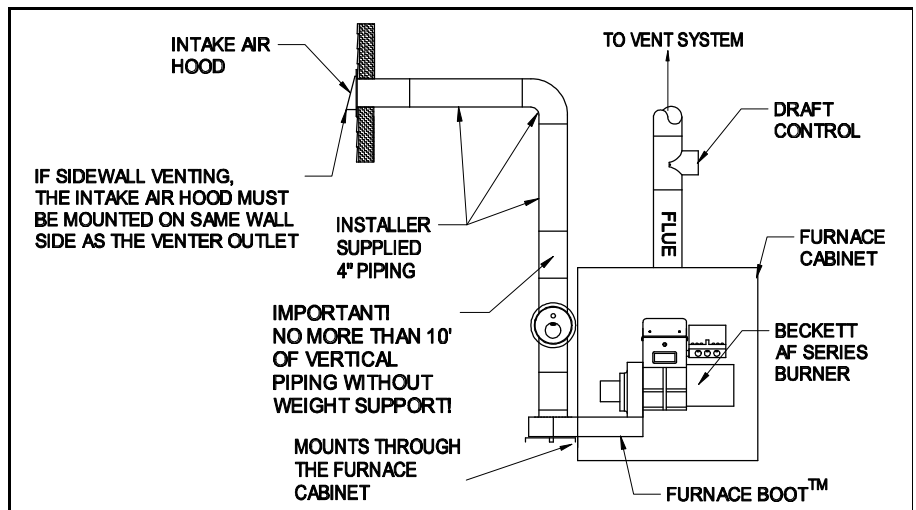

Figure 9

INSTALLATION OF INLET VENT TERMINATION

1. Cut a 4-1/4" diameter hole through the sidewall of the building.
2. Slide the inlet vent pipe through the hole and fasten to the wall with appropriate fasteners. Seal the edges of the mounting plate with a silicone sealant or equivalent.

INSTALLATION OF DUCT WORK

1. Duct length distance, a maximum of 30 linear feet of standard duct pipe and two (2) 90° elbows. Subtract 7 feet from the maximum linear feet for every 90° elbow added. Maximum linear footage will be less for flex duct. Consult flex duct manufacturer for equivalent lengths.

Pipe Diameter	Maximum Linear Feet	Feet/Elbow*
5"	60'	9'
6"	90'	11'
*Subtract footage from the maximum linear feet for every 90° elbow		

Longer pipe lengths require the use of a larger pipe between the VRV and the intake hood. It also requires the use of a vent pipe increaser at the VRV and a reducer at the intake hood.

2. Route the duct work from the VRV tee to the inlet vent termination with as minimum a number of elbows as possible.
3. Secure and support the duct work for the design and weight of the material used, to prevent physical damage and separation of joints. For guidelines refer to recognized national building codes or according to any local codes.
4. To reduce uncontrolled air leakage into the duct, tape all joints and seams using standard duct tape.

NOTE: To prevent sweating on the outside of the duct, when operating in areas that have -10°F or below design temperatures, insulate the duct work at least 10 feet from the inlet vent termination.

OPERATION: AIR ADJUSTMENT

1. Adjust the air adjustment knob on the side of the Furnace Boot™ (See Table 1) to rough air setting.
2. Start the burner and adjust the air control as needed to achieve the required CO2 and smoke levels. Set over fire draft to appliance manufacturers' specifications (typically -.02" of water). Secure air control knob with indicator bracket. If draft levels are not obtainable or controllable, use standard industry methods to control the draft or call the Field Controls Tech Line at 1-800-742-8368 for more information.

Table 1

ROUGH AIR SETTING	
GPH	Knob Setting
.75	25°
1.00	60°
1.50	160°

3. Next, adjust the VRV gate by screwing the adjustment weight in until the VRV gate is just closed.
4. Re-check the burners operation and adjust accordingly.
5. Lock the adjustment weight in position by tightening the hex nut on the VRV gate.

