



Installation & Operation Manual
Models: 399 - 800



⚠ WARNING

This manual must only be used by a qualified heating installer / service technician. Read all instructions, including this manual and the Knight XL Service Manual, before installing. Perform steps in the order given. Failure to comply could result in severe personal injury, death, or substantial property damage.



Lochinvar[®]
High Efficiency Water Heaters, Boilers and Pool Heaters

Save this manual for future reference.

Contents

HAZARD DEFINITIONS	2	Vertical Termination - Optional Room Air	29
PLEASE READ BEFORE PROCEEDING	3	Vertical Termination - Optional Concentric Vent	30-31
THE KNIGHT XL -- HOW IT WORKS	4-6	6. HYDRONIC PIPING	
RATINGS	7	System Water Piping Methods	32
1. DETERMINE BOILER LOCATION		Low Water Cutoff Device	32
Provide Air Openings to Room	10	Chilled Water System	32
Flooring and Foundation	10	Freeze Protection	32
Residential Garage Installation	10	General Piping Information	32
Vent and Air Piping	10	Flow Switch and Relief Valve Installation	33
Prevent Combustion Air Contamination	10	Flow Switch Adjustment	33
Corrosive Contaminants and Sources	11	Circulator Sizing	34
Removing a Boiler from Existing Common Vent	11	Near Boiler Piping Connections	34
2. PREPARE BOILER		Near Boiler Piping Components	36
Remove Boiler from Wood Pallet	12	7. GAS CONNECTIONS	
Gas Conversions	12	Connecting Gas Supply Piping	39
Model 399	12	Natural Gas	40
Model 500	13	Pipe Sizing for Natural Gas	40
Models 600 - 800	13	Natural Gas Supply Pressure Requirements	40
Leveling the Boiler	13	Propane Gas	40
3. GENERAL VENTING		Pipe Sizing for Propane Gas	40
Direct Venting Options	14-15	Propane Supply Pressure Requirements	40
Install Vent and Combustion Air Piping	16	Check Inlet Gas Supply	41
PVC/CPVC Vent Piping Materials	16	Gas Pressure	42
Requirements for Installation in Canada	16	Gas Valve Replacement	42
PVC/CPVC Air Intake/Vent Connections	17	8. FIELD WIRING	
Air Inlet Pipe Materials	17	Line Voltage Connections	43
Stainless Steel Vent and Air Piping	18	Low Voltage Connections	44
Min./Max. Combustion Air & Vent Piping Lengths	19	Wiring of the Cascade	45
Removing from Existing Vent	19	9. CONDENSATE DISPOSAL	
Vent and Air Piping	19	Condensate Drain	47
4. SIDEWALL DIRECT VENTING		10. STARTUP	48-53
Vent/Air Termination - Sidewall	20-23	11. OPERATING INFORMATION	
Determine Location	20-21	General	54
Prepare Wall Penetrations	22-23	Cascade	56-57
Termination and Fittings	23	Sequence of Operation	58
Multiple Vent/Air Terminations	23	Knight XL Control Module	59-60
Sidewall Termination - Optional Concentric Vent	24-26	Status Display Screens	61-64
5. VERTICAL DIRECT VENTING		12. MAINTENANCE	
Vent/Air Termination - Vertical	27-28	Maintenance and Annual Startup	65-69
Determine Location	27	13. DIAGRAMS	
Prepare Roof Penetrations	28	Wiring Diagram	70
Termination and Fittings	28	Ladder Diagram	71
Multiple Vent/Air Terminations	28	Revision Notes	Back Cover

Hazard definitions

The following defined terms are used throughout this manual to bring attention to the presence of hazards of various risk levels or to important information concerning the life of the product.

⚠ DANGER

DANGER indicates an imminently hazardous situation which, if not avoided, will result in death or serious injury.

⚠ WARNING

WARNING indicates a potentially hazardous situation which, if not avoided, could result in death or serious injury.

⚠ CAUTION

CAUTION indicates a potentially hazardous situation which, if not avoided, may result in minor or moderate injury.

CAUTION

CAUTION used without the safety alert symbol indicates a potentially hazardous situation which, if not avoided, may result in property damage.

NOTICE

NOTICE indicates special instructions on installation, operation, or maintenance that are important but not related to personal injury or property damage.

Please read before proceeding

⚠ WARNING

Installer – Read all instructions, including this manual and the Knight XL Service Manual, before installing. Perform steps in the order given.

User – This manual is for use only by a qualified heating installer/service technician. Refer to the User's Information Manual for your reference.

Have this boiler serviced/inspected by a qualified service technician, at least annually.

Failure to comply with the above could result in severe personal injury, death or substantial property damage.

NOTICE

When calling or writing about the boiler – Please have the boiler model and serial number from the boiler rating plate.

Consider piping and installation when determining boiler location.

Any claims for damage or shortage in shipment must be filed immediately against the transportation company by the consignee.

Factory warranty (shipped with unit) does not apply to units improperly installed or improperly operated.

⚠ WARNING

Failure to adhere to the guidelines on this page can result in severe personal injury, death, or substantial property damage.

⚠ WARNING

If the information in this manual is not followed exactly, a fire or explosion may result causing property damage, personal injury or loss of life.

This appliance **MUST NOT** be installed in any location where gasoline or flammable vapors are likely to be present.

WHAT TO DO IF YOU SMELL GAS

- Do not try to light any appliance.
- Do not touch any electric switch; do not use any phone in your building.
- Immediately call your gas supplier from a near by phone. Follow the gas supplier's instructions.
- If you cannot reach your gas supplier, call the fire department.
- Installation and service must be performed by a qualified installer, service agency, or the gas supplier.

When servicing boiler –

- To avoid electric shock, disconnect electrical supply before performing maintenance.
- To avoid severe burns, allow boiler to cool before performing maintenance.

Boiler operation –

- Do not block flow of combustion or ventilation air to the boiler.
- Should overheating occur or gas supply fail to shut off, do not turn off or disconnect electrical supply to circulator. Instead, shut off the gas supply at a location external to the appliance.
- Do not use this boiler if any part has been under water. The possible damage to a flooded appliance can be extensive and present numerous safety hazards. Any appliance that has been under water must be replaced.

Boiler water –

- Thoroughly flush the system (without boiler connected) to remove sediment. The high-efficiency heat exchanger can be damaged by build-up or corrosion due to sediment.
- Do not use petroleum-based cleaning or sealing compounds in the boiler system. Gaskets and seals in the system may be damaged. This can result in substantial property damage.
- Do not use “homemade cures” or “boiler patent medicines”. Serious damage to the boiler, personnel, and/or property may result.
- Continual fresh make-up water will reduce boiler life. Mineral buildup in the heat exchanger reduces heat transfer, overheats the stainless steel heat exchanger, and causes failure. Addition of oxygen carried in by makeup water can cause internal corrosion in system components. Leaks in boiler or piping must be repaired at once to prevent makeup water.

Freeze protection fluids –

- NEVER use automotive antifreeze. Use only inhibited propylene glycol solutions, which are specifically formulated for hydronic systems. Ethylene glycol is toxic and can attack gaskets and seals used in hydronic systems.

The Knight XL - How it works...

- 1. Stainless steel heat exchanger**
Allows system water to flow through specially designed coils for maximum heat transfer, while providing protection against flue gas corrosion. The coils are encased in a jacket that contains the combustion process.
- 2. Heat exchanger access cover**
Allows access to the combustion side of the heat exchanger coils.
- 3. Blower**
The blower pulls in air and gas through the venturi (item 5). Air and gas mix inside the blower and are pushed into the burner, where they burn inside the combustion chamber.
- 4. Gas valve**
The gas valve senses the negative pressure created by the blower, allowing gas to flow only if the gas valve is powered and combustion air is flowing.
- 5. Venturi**
The venturi controls air and gas flow into the burner.
- 6. Flue gas sensor**
This sensor monitors the flue gas exit temperature. The control module will modulate and shut down the boiler if the flue gas temperature gets too hot. This protects the flue pipe from overheating.
- 7. Boiler outlet temperature sensor**
This sensor monitors boiler outlet water temperature (system supply). If selected as the controlling sensor, the control module adjusts boiler firing rate so the outlet temperature is correct.
- 8. Boiler inlet temperature sensor**
This sensor monitors return water temperature (system return). If selected as the controlling sensor, the control module adjusts the boiler firing rate so the inlet temperature is correct.
- 9. Temperature and pressure gauge (field installed, not shown)**
Monitors the outlet temperature of the boiler as well as the system water pressure.
- 10. Electronic display**
The electronic display consists of 7 buttons and a dual line 32-character liquid crystal display.
- 11. Flue pipe adapter**
Allows for the connection of the PVC vent pipe system to the boiler.
- 12. Burner (not shown)**
Made with metal fiber and stainless steel construction, the burner uses pre-mixed air and gas and provides a wide range of firing rates.
- 13. Water outlet (system supply)**
A 1-1/2" or 2" NPT (depending on the model) water connection that supplies hot water to the system.
- 14. Water inlet (system return)**
A 1-1/2" or 2" NPT (depending on the model) water connection that returns water from the system to the heat exchanger.
- 15. Gas connection pipe**
Threaded pipe connection, either 1" or 1-1/2", depending on the model. This pipe should be connected to the incoming gas supply for the purpose of delivering gas to the boiler.
- 16. SMART Control Module**
The SMART Control responds to internal and external signals and controls the blower, gas valve, and pumps to meet the heating demand.
- 17. Automatic air vent**
Designed to remove trapped air from the heat exchanger coils.
- 18. Air intake adapter**
Allows for the connection of the PVC air intake pipe to the boiler.
- 19. High voltage junction box**
The junction box contains the connection points for the line voltage power and all pumps.
- 20. Boiler drain port**
Location from which the heat exchanger can be drained.
- 21. Low voltage connection board**
The connection board is used to connect external low voltage devices.
- 22. Low voltage wiring connections (knockouts)**
Conduit connection points for the low voltage connection board.
- 23. Condensate drain connection**
Connects the condensate drain line to a 1/2" PVC union.
- 24. Access cover - front**
Provides access to the gas train and the heat exchanger.
- 25. Ignition electrode**
Provides direct spark for igniting the burner.
- 26. Flame inspection window**
The quartz glass window provides a view of the burner surface and flame.
- 27. Gas shutoff valve**
Manual valve used to isolate the gas valve from the gas supply.
- 28. High limit**
Device that monitors the outlet water temperature. If the temperature exceeds its setting, it will break the control circuit, shutting the boiler down.
- 29. Relief valve**
Protects the heat exchanger from an over pressure condition. The relief valve will be set at 50 PSI.
- 30. Flame sensor**
Used by the control module to detect the presence of burner flame.
- 31. Line voltage wiring connections (knockouts)**
Conduit connection points for the high voltage junction box.
- 32. Top panel**
Removable panel to gain access to the internal components.
- 33. Power switch**
Turns 120 VAC ON/OFF to the boiler.
- 34. Leveling legs**
Used to allow the heat exchanger to be leveled. This is needed for the proper draining of the condensate from the combustion chamber.
- 35. Air shroud (Model 500 only)**
The air shroud controls air and gas flow into the burner.

The Knight XL - How it works... *(continued)*

36. Air pressure switch

The air pressure switch detects blocked flue/inlet conditions.

37. Pump relay board

The pump relay board is used to connect the boiler, system and DHW pumps.

Model 399

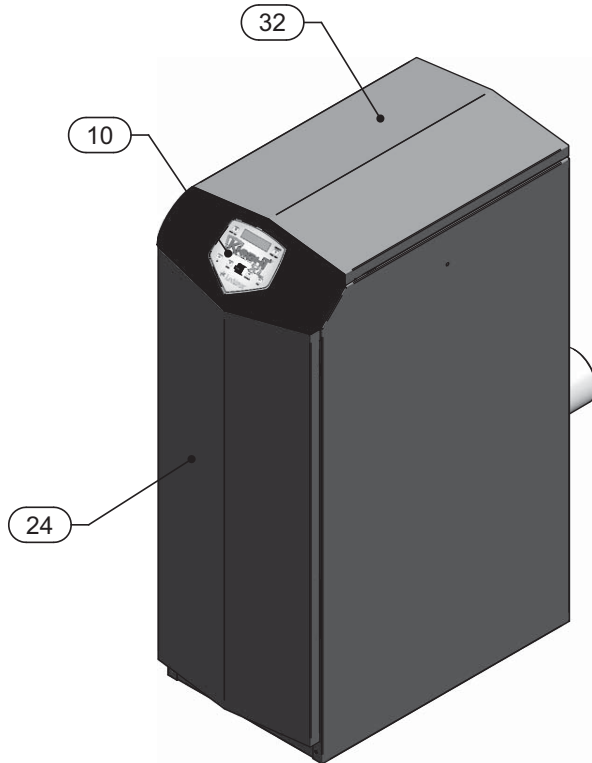

Front View - Model 399

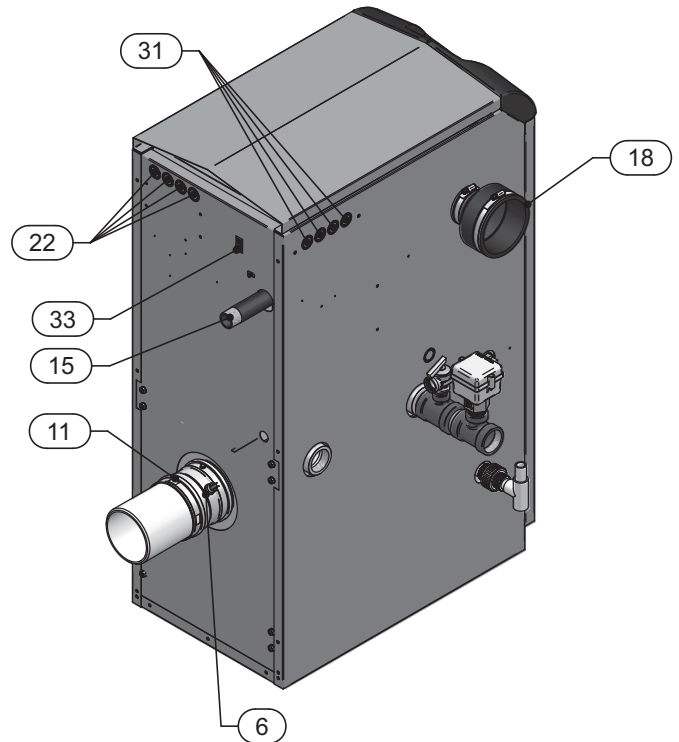

Rear View - Model 399

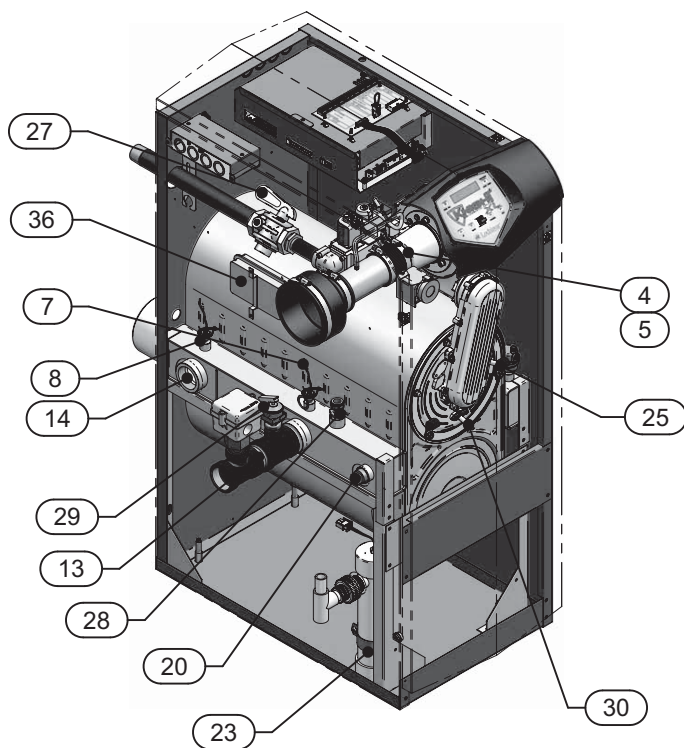

Left Side (inside unit) - Model 399

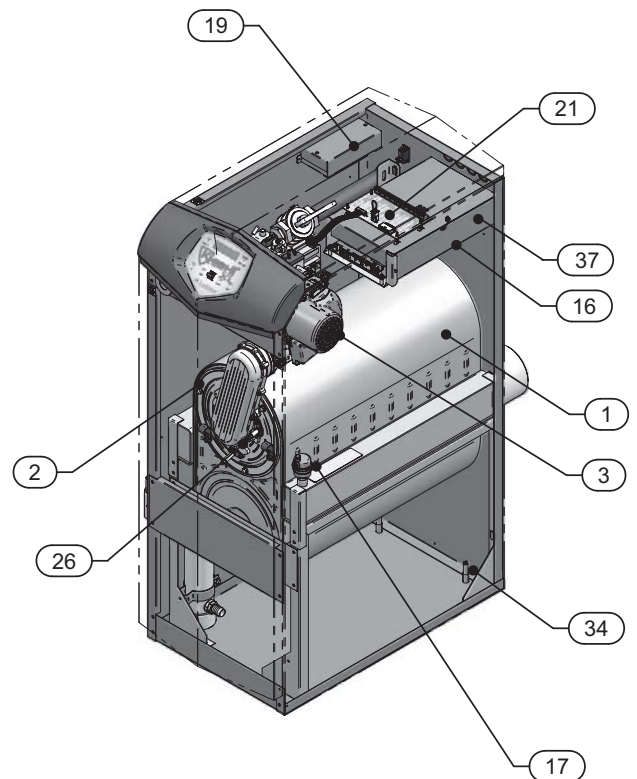

Right Side (inside unit) - Model 399

The Knight XL - How it works...

Model 500

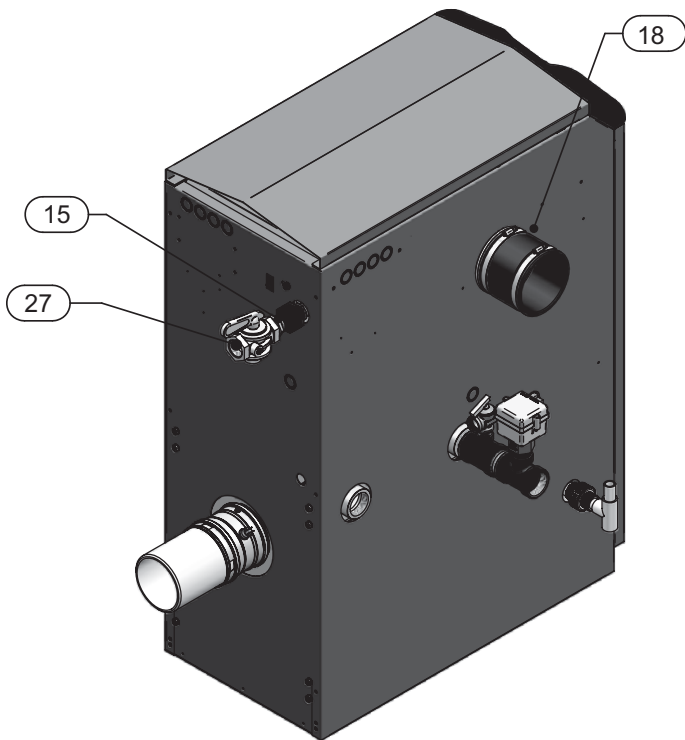

Rear View - Model 500

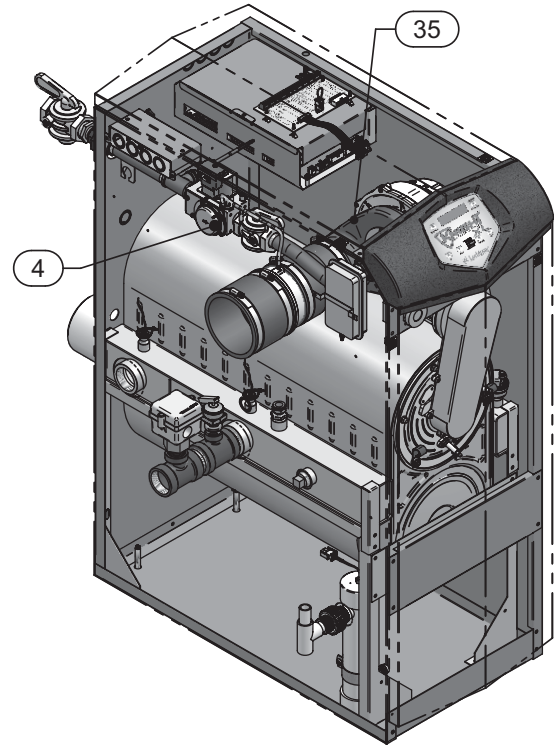

Left Side (inside unit) - Model 500

Models 600 - 800

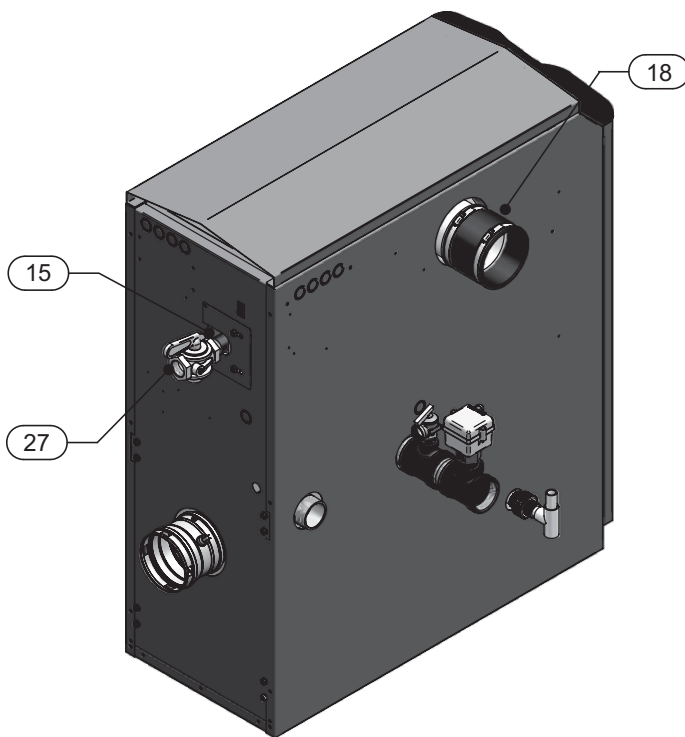

Rear View - Models 600 - 800

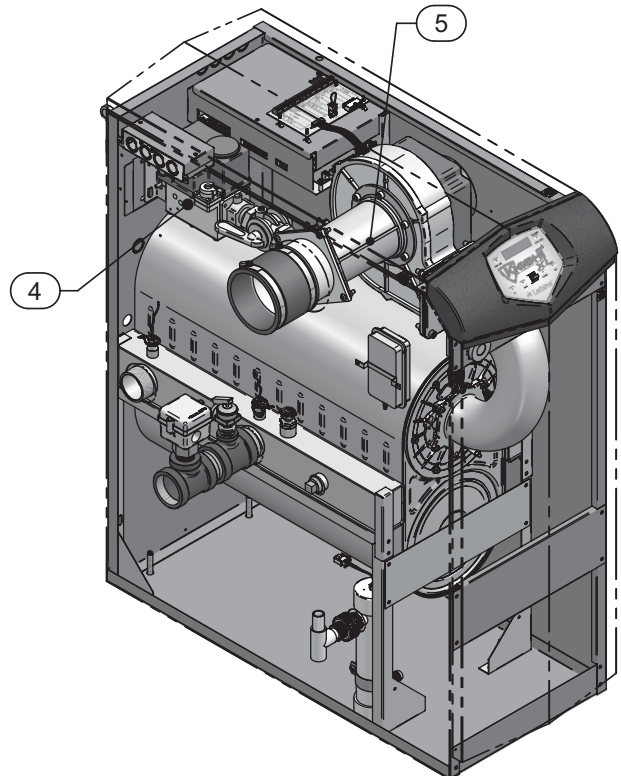

Left Side (inside unit) - Models 600 - 800

Ratings

DOE

Knight XL Boiler I=B=R Rating					Other Specifications				
Model Number <small>Note: Change "N" to "L" for L.P. gas models.</small>	Input MBH <small>(Note 4)</small>		Gross Output MBH <small>(Note 1)</small>	Net I=B=R Ratings Water, MBH <small>(Note 2)</small>	Boiler Water Content Gallons	Water Connections	Gas Connections	Air Size	Vent Size <small>(Note 3)</small>
	Min	Max							
KBN399	80	399	373	324	3.4	1-1/2"	1"	4"	4"
KBN500	100	500	467	406	4.2	1-1/2"	1"	4"	4"
KBN600	120	600	567	493	4.2	2"	1"	4"	4"
KBN700	140	700	660	574	5.0	2"	1"	4"	6"
KBN800	160	800	752	654	5.7	2"	1"	4"	6"

NOTICE

Maximum allowed working pressure is located on the rating plate.

Notes:

- The ratings are based on standard test procedures prescribed by the United States Department of Energy.
- Net I=B=R ratings are based on net installed radiation of sufficient quantity for the requirements of the building and nothing need be added for normal piping and pickup. Ratings are based on a piping and pickup allowance of 1.15.
- Knight XL boilers require special gas venting. Use only the vent materials and methods specified in the Knight XL Installation and Operation Manual.
- Standard Knight XL boilers are equipped for operation up to 4,500 feet with no field adjustments. Output ratings will be reduced by 4% for each 1,000 feet above sea level up to 4,500 feet only.
- High altitude Knight XL boilers will have a high altitude label affixed to the unit (as shown in FIG. A) and are equipped for operation of 4,501 feet to 12,000 feet only with no field adjustments. For high altitude models, output ratings will be reduced by 2% for each 1,000 feet above sea level.

High altitude models have a different control module for altitude operation, but the operation given in this manual for standard models remains the same.

- Ratings have been confirmed by the Hydronics Institute, Division of AHRI.

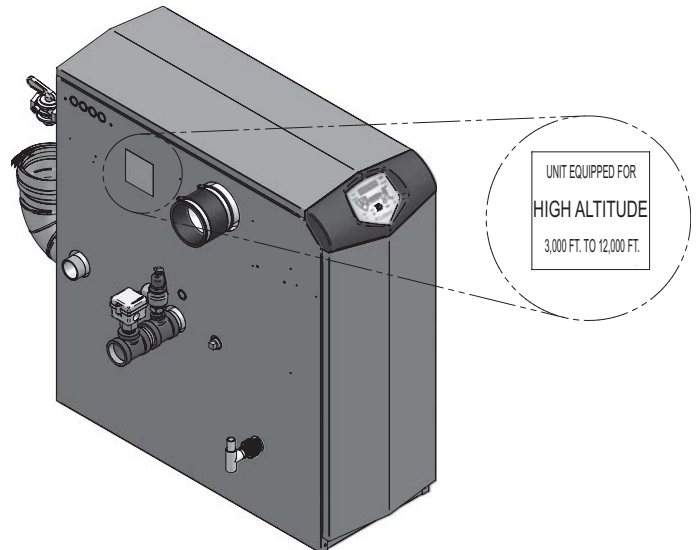
Figure A High Altitude Label Location

1 Determine boiler location

Installation must comply with:

- Local, state, provincial, and national codes, laws, regulations, and ordinances.
- National Fuel Gas Code, ANSI Z223.1 – latest edition.
- Standard for Controls and Safety Devices for Automatically Fired Boilers, ANSI/ASME CSD-1, when required.
- National Electrical Code.
- For Canada only: B149.1 Installation Code, CSA C22.1 Canadian Electrical Code Part 1 and any local codes.

NOTICE

The Knight XL gas manifold and controls met safe lighting and other performance criteria when the boiler underwent tests specified in ANSI Z21.13 – latest edition.

Before locating the boiler, check:

1. Check for nearby connection to:
 - System water piping
 - Venting connections
 - Gas supply piping
 - Electrical power
2. Locate the appliance so that if water connections should leak, water damage will not occur. When such locations cannot be avoided, it is recommended that a suitable drain pan, adequately drained, be installed under the appliance. The pan must not restrict combustion air flow. Under no circumstances is the manufacturer to be held responsible for water damage in connection with this appliance, or any of its components.
3. Check area around the boiler. Remove any combustible materials, gasoline and other flammable liquids.

WARNING

Failure to keep boiler area clear and free of combustible materials, gasoline, and other flammable liquids and vapors can result in severe personal injury, death, or substantial property damage.

4. The Knight XL must be installed so that gas control system components are protected from dripping or spraying water or rain during operation or service.
5. If a new boiler will replace an existing boiler, check for and correct system problems, such as:
 - System leaks causing oxygen corrosion or heat exchanger cracks from hard water deposits.
 - Incorrectly-sized expansion tank.
 - Lack of freeze protection in boiler water causing system and boiler to freeze and leak.

WARNING

This appliance is certified as an indoor appliance. Do not install the appliance outdoors or locate where the appliance will be exposed to freezing temperatures or to temperatures that exceed 100°F (37.8°C).

Failure to install the appliance indoors could result in severe personal injury, death, or substantial property damage.

WARNING

This appliance requires a special venting system. The vent connection to the appliance must be made with the starter CPVC/stainless steel pipe section provided with the appliance. The field provided PVC vent fittings must be cemented to the CPVC pipe section. Use only the vent materials, primer and cement specified in this manual to make the vent connections. Failure to follow this warning could result in fire, personal injury, or death.

Closet and alcove installations

A closet is any room the boiler is installed in which is less than 171 cubic feet for KBN399 models, 193 cubic feet for KBN500 models, 223 cubic feet for KBN600 models, 247 cubic feet for KBN700 models and 278 cubic feet for KBN800 models.

An alcove is any room which meets the criteria for a closet with the exception that it does not have a door.

Example: Room dimensions = 5 feet long, 4 feet wide, and 8 foot ceiling = 5 x 4 x 8 = 160 cubic feet. This would be considered a closet for a Knight XL Boiler.

WARNING

For closet and alcove installations as shown in FIG.'s 1-1 and 1-2, CPVC or stainless steel vent material must be used inside the structure. The ventilating air openings shown in FIG.'s 1-1 and 1-2 are required for this arrangement. Failure to follow this warning could result in fire, personal injury, or death.

Provide clearances:

Clearances from combustible materials

1. Hot water pipes—at least 1" (25 mm) from combustible materials.
2. Vent pipe – at least 1" (25 mm) from combustible materials.
3. See FIG.'s 1-1 and 1-2 on page 9 for other clearance minimums.

Clearances for service access

1. See FIG.'s 1-1 and 1-2 on page 9 for recommended service clearances. If you do not provide the minimum clearances shown, it may not be possible to service the boiler without removing it from the space.

1 Determine boiler location *(continued)*

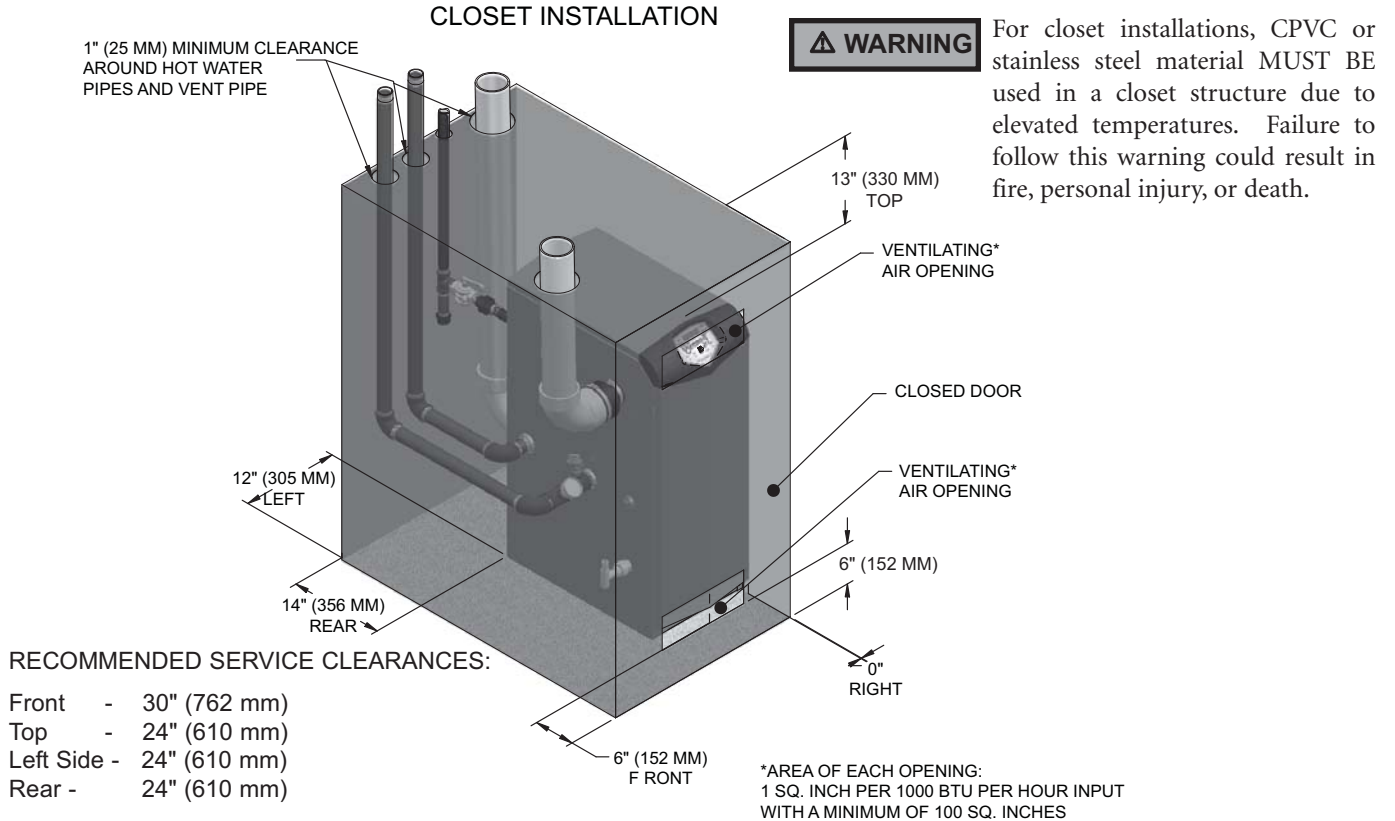
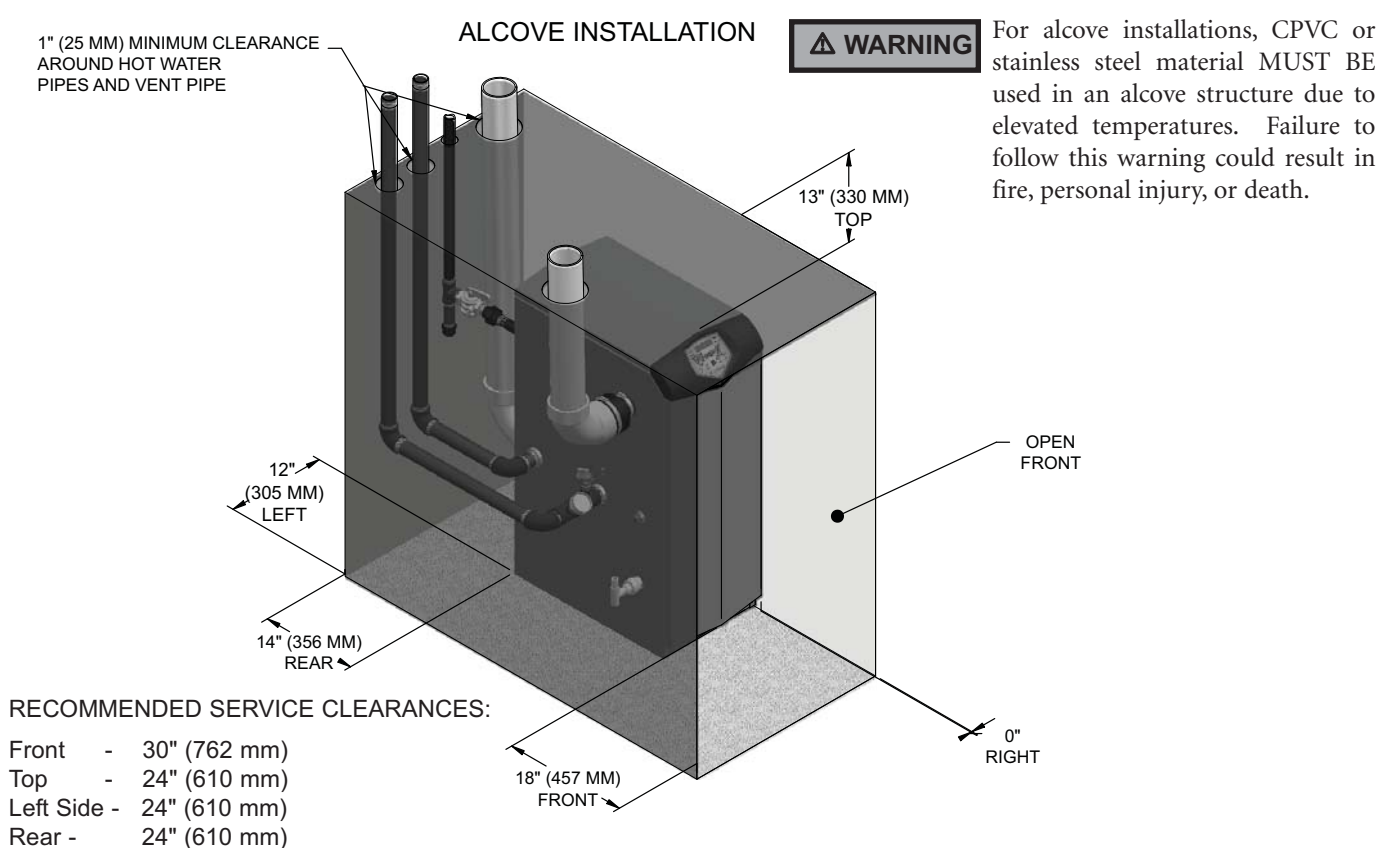
Figure 1-1 Closet Installation - Minimum Required Clearances

Figure 1-2 Alcove Installation - Minimum Required Clearances

1 Determine boiler location

Provide air openings to room:

Knight XL alone in boiler room

1. No air ventilation openings into the boiler room are needed when clearances around the Knight XL are at least equal to the SERVICE clearances shown in FIG.'s 1-1 and 1-2. For spaces that do NOT supply this clearance, provide two openings as shown in FIG. 1-1. Each opening must provide one square inch free area per 1,000 Btu/hr of boiler input.

Knight XL in same space with other gas or oil-fired appliances

1. Follow the National Fuel Gas Code (U.S.) or CSA B149.1 (Canada) to size/verify size of the combustion/ventilation air openings into the space.

⚠ WARNING The space must be provided with combustion/ventilation air openings correctly sized for all other appliances located in the same space as the Knight XL.

Do not install the boiler in an attic.

Failure to comply with the above warnings could result in severe personal injury, death, or substantial property damage.

2. Size openings only on the basis of the other appliances in the space. No additional air opening free area is needed for the Knight XL because it takes its combustion air from outside (direct vent installation).

Flooring and foundation

Flooring

The Knight XL is approved for installation on combustible flooring, but must never be installed on carpeting.

⚠ WARNING Do not install the boiler on carpeting even if foundation is used. Fire can result, causing severe personal injury, death, or substantial property damage.

If flooding is possible, elevate the boiler sufficiently to prevent water from reaching the boiler.

Residential garage installation

Precautions

Take the following precautions when installing the appliance in a residential garage. If the appliance is located in a residential garage, it should be installed in compliance with the latest edition of the National Fuel Gas Code, ANSI Z223.1 and/or CAN/CGA-B149 Installation Code.

- Appliances located in residential garages and in adjacent spaces that open to the garage and are not part of the living space of a dwelling shall be installed so that all burners and burner ignition devices are located not less than 18 inches (46 cm) above the floor.
- The appliance shall be located or protected so that it is not subject to physical damage by a moving vehicle.

Vent and air piping

The Knight XL requires a special vent system, designed for pressurized venting.

You must also install air piping from outside to the boiler air intake adapter. The resultant installation is direct vent (sealed combustion). Note prevention of combustion air contamination below when considering vent/air termination.

Vent and air must terminate near one another and may be vented vertically through the roof or out a side wall. You may use any of the vent/air piping methods covered in this manual. Do not attempt to install the Knight XL using any other means.

Be sure to locate the boiler such that the vent and air piping can be routed through the building and properly terminated. The vent/air piping lengths, routing and termination method must all comply with the methods and limits given in this manual.

Prevent combustion air contamination

Install air inlet piping for the Knight XL as described in this manual. Do not terminate vent/air in locations that can allow contamination of combustion air. Refer to Table 1A, page 11 for products and areas which may cause contaminated combustion air.

⚠ WARNING You must pipe combustion air to the boiler air intake. Ensure that the combustion air will not contain any of the contaminants in Table 1A, page 11. Contaminated combustion air will damage the boiler, resulting in possible severe personal injury, death or substantial property damage. Do not pipe combustion air near a swimming pool, for example. Also, avoid areas subject to exhaust fumes from laundry facilities. These areas will always contain contaminants.

1 Determine boiler location *(continued)*

Table 1A Corrosive Contaminants and Sources

Products to avoid:
Spray cans containing chloro/fluorocarbons
Permanent wave solutions
Chlorinated waxes/cleaners
Chlorine-based swimming pool chemicals
Calcium chloride used for thawing
Sodium chloride used for water softening
Refrigerant leaks
Paint or varnish removers
Hydrochloric acid/muriatic acid
Cements and glues
Antistatic fabric softeners used in clothes dryers
Chlorine-type bleaches, detergents, and cleaning solvents found in household laundry rooms
Adhesives used to fasten building products and other similar products
Areas likely to have contaminants
Dry cleaning/laundry areas and establishments
Swimming pools
Metal fabrication plants
Beauty shops
Refrigeration repair shops
Photo processing plants
Auto body shops
Plastic manufacturing plants
Furniture refinishing areas and establishments
New building construction
Remodeling areas
Garages with workshops

When removing a boiler from existing common vent system:

⚠ DANGER

Do not install the Knight XL into a common vent with any other appliance. This will cause flue gas spillage or appliance malfunction, resulting in possible severe personal injury, death, or substantial property damage.

⚠ WARNING

Failure to follow all instructions can result in flue gas spillage and carbon monoxide emissions, causing severe personal injury or death.

At the time of removal of an existing boiler, the following steps shall be followed with each appliance remaining connected to the common venting system placed in operation, while the other appliances remaining connected to the common venting system are not in operation.

- a. Seal any unused openings in the common venting system.
- b. Visually inspect the venting system for proper size and horizontal pitch and determine there is no blockage or restriction, leakage, corrosion, or other deficiencies, which could cause an unsafe condition.
- c. Test vent system – Insofar as is practical, close all building doors and windows and all doors between the space in which the appliances remaining connected to the common venting system are located and other spaces of the building. Turn on clothes dryers and any appliance not connected to the common venting system. Turn on any exhaust fans, such as range hoods and bathroom exhausts, so they will operate at maximum speed. Do not operate a summer exhaust fan. Close fireplace dampers.
- d. Place in operation the appliance being inspected. Follow the lighting instructions. Adjust thermostat so appliance will operate continuously.
- e. Test for spillage at the draft hood relief opening after 5 minutes of main burner operation. Use the flame of a match or candle, or smoke from a cigarette, cigar, or pipe.
- f. After it has been determined that each appliance remaining connected to the common venting system properly vents when tested as outlined herein, return doors, windows, exhaust fans, fireplace dampers, and any other gas-burning appliance to their previous conditions of use.
- g. Any improper operation of the common venting system should be corrected so the installation conforms with the National Fuel Gas Code, ANSI Z223.1/NFPA 54 and/or CAN/CSA B149.1, Natural Gas and Propane Installation Code. When resizing any portion of the common venting system, the common venting system should be resized to approach the minimum size as determined using the appropriate tables in Part 11 of the National Fuel Gas Code, ANSI Z223.1/NFPA and/or CAN/CSA B149.1, Natural Gas and Propane Installation Code.

2 Prepare boiler

Remove boiler from wood pallet

1. After removing the outer shipping carton from the boiler, remove the parts box.
2. Remove the front door to access the lag bolts in front of the unit (FIG. 2-1).
3. To remove the boiler from the pallet (after removing the front door):
 - a. Remove the two lag bolts from the wood pallet inside the boiler (FIG. 2-1).
 - b. Detach the boiler from the lag bolts in the rear of the unit, see FIG. 2-1.

NOTICE

Do not drop the boiler or bump the jacket on the floor or pallet. Damage to the boiler can result.

Figure 2-1 Boiler Mounted on Shipping Pallet

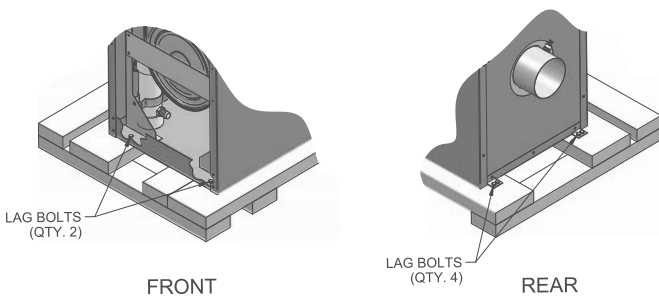

Gas conversions

⚠ WARNING

For a boiler already installed, you must turn off gas supply, turn off power and allow boiler to cool before proceeding. You must also completely test the boiler after conversion to verify performance as described under Start-up, Section 10 of this manual. Failure to comply could result in severe personal injury, death, or substantial property damage.

For the 399 Model you must install a propane orifice to operate the Knight XL on propane gas. Verify when installing that the orifice size marking matches boiler size (Model 399 - 8.0 LP orifice stamping).

Models 500 - 800 do not require an orifice installation for propane operation, but they will require a valve adjustment.

Model 399

1. Remove the top and front access covers from the unit (no tools required for removal).
2. Remove the three screws securing the venturi to the blower.

Note: When separating the venturi from the blower, take care not to damage the O-ring inside the blower (FIG. 2-2).
3. Remove the four star-drive screws securing the gas valve to the venturi (FIG. 2-2).
4. Locate the propane orifice disk from the conversion kit bag. Verify that the stamping on the orifice disk matches the boiler size (Model 399 - 8.0 LP orifice stamping).
5. Remove the existing orifice from the O-ring in the side of the gas valve and replace it with the orifice from the kit. Position and secure the orifice in the valve as shown in FIG. 2-2.
6. Reposition the gas valve against the venturi and replace the star-drive screws (FIG. 2-2) securing the valve to the venturi.
7. Inspect the O-ring inside the blower. Handle the O-ring with care, do not damage. Reposition the venturi against the blower and replace the screws securing the venturi to the blower (FIG. 2-2).
8. After installation is complete, attach the propane conversion label (in the conversion kit bag) next to the boiler rating plate. Attach the LP caution label (in the conversion kit bag) to the left side of the unit in the lower left corner.
9. Replace the top and front access covers.

⚠ WARNING

After converting to LP, check combustion per the Start-up procedure in Section 10 of this manual. Failure to check and verify combustion could result in severe personal injury, death, or substantial property damage.

⚠ DANGER

Model 399: Inspect the O-ring when the blower is disassembled. The O-ring must be in good condition and must be installed. Failure to comply will cause a gas leak, resulting in severe personal injury or death.

Figure 2-2 Installing Propane Orifice - Model 399

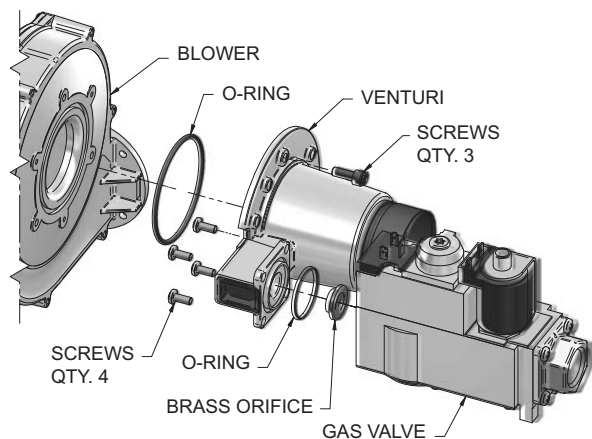

2 Prepare boiler *(continued)*

Model 500

1. Remove the top access cover from the unit (no tools required for removal).
2. Turn the adjustment screw on the gas valve clockwise until it stops. Then turn the adjustment screw counterclockwise four and three quarter (4 3/4) turns (see FIG. 2-3).
3. Use a combustion analyzer to verify CO₂ is within the range of 9.6 – 10.5%. If not, adjust the screw **counterclockwise** incrementally to raise CO₂ and **clockwise** to lower CO₂ (FIG. 2-3).
4. After adjustment is complete, attach the propane conversion label (in the conversion kit bag) next to the boiler rating plate. Attach the LP caution label (in the conversion kit bag) to the left side of the unit in the lower left corner.
5. Replace the top access cover.

⚠ WARNING After converting to LP, check combustion per the Start-up procedure in Section 10 of this manual. Failure to check and verify combustion could result in severe personal injury, death, or substantial property damage.

Figure 2-3 Gas Valve Adjustment - Model 500

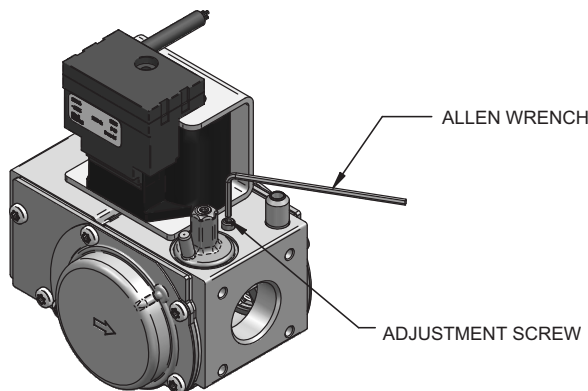

Models 600 - 800

1. Remove the top access cover from the unit (no tools required for removal).
2. Remove the cover on top of the gas valve (FIG. 2-4).
3. Turn the adjustment screw on top of the gas valve clockwise one and three quarter (1 3/4) turns on the 600 Model, one and a half (1 1/2) turns on the 700 Model, and one turn on the 800 Model (see FIG. 2-4).
4. Use a combustion analyzer to verify CO₂ is within the range of 9.6 – 10.5%. If not, adjust the screw **counterclockwise** incrementally to raise CO₂ and **clockwise** to lower CO₂ (FIG. 2-4).
5. After adjustment is complete, attach the propane conversion label (in the conversion kit bag) next to the boiler rating plate. Attach the LP caution label (in the conversion kit bag) to the left side of the unit in the lower left corner.
6. Replace the gas valve cover along with the top access cover.

⚠ WARNING

After converting to LP, check combustion per the Start-up procedure in Section 10 of this manual. Failure to check and verify combustion could result in severe personal injury, death, or substantial property damage.

Figure 2-4 Gas Valve Adjustment - Models 600 - 800

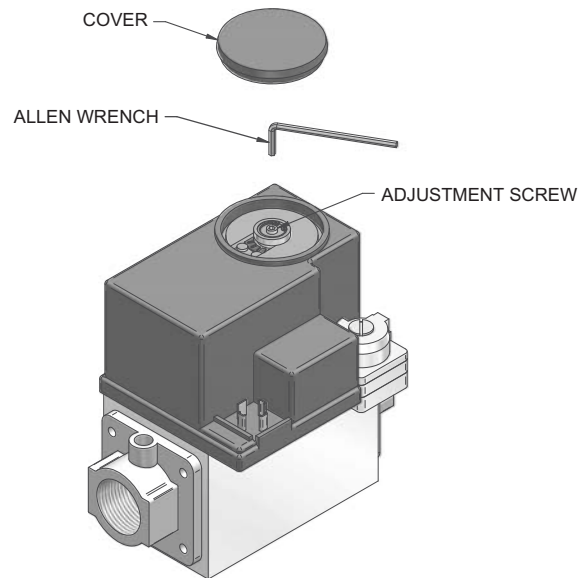

Leveling the boiler

1. Set the boiler in place and check level.
 - a) Adjust legs if necessary to level boiler, see FIG. 2-5 below.

Figure 2-5 Leveling Legs on the Boiler

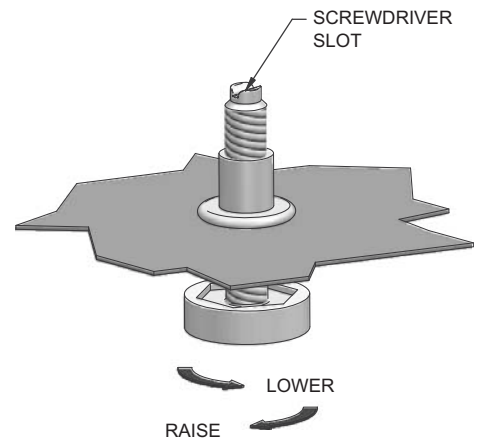

3 General venting

Direct venting options - Sidewall Vent

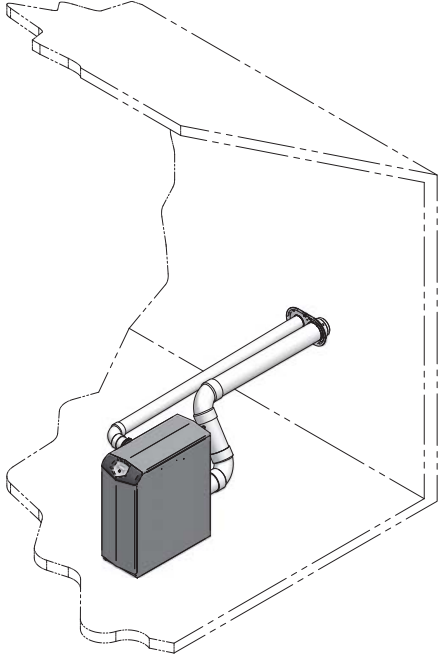

PVC/CPVC Two Pipe
See Figure 4-1A
Models 399 - 600 Only

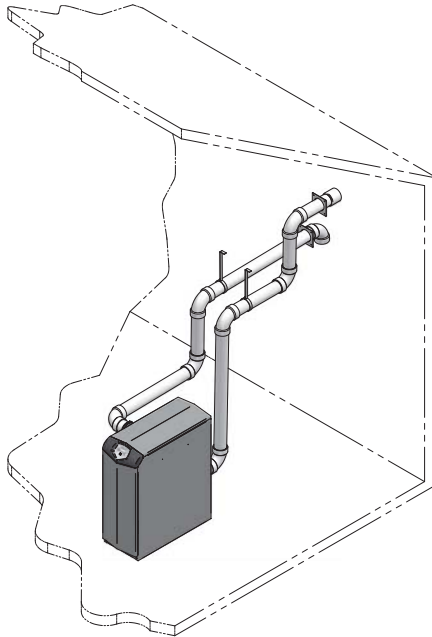

PVC/CPVC Alternate Two Pipe
See Figure 4-2A

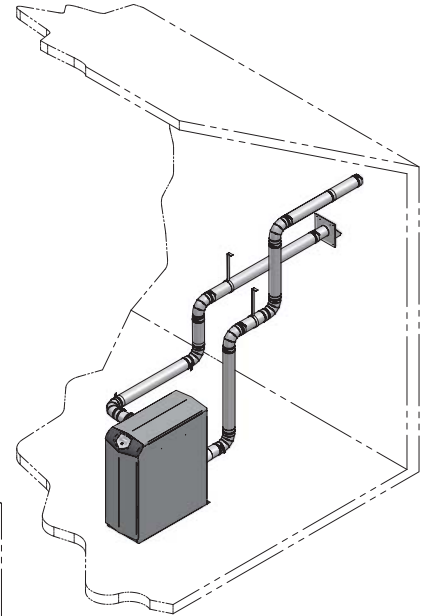

Stainless Steel Two Pipe
See Figure 4-1C
Models 399 - 600 Only

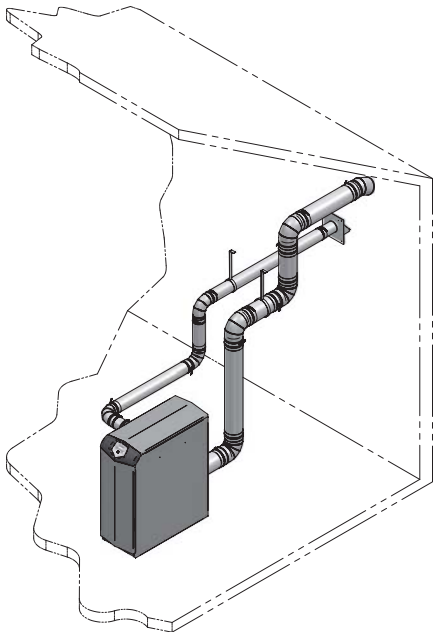

Stainless Steel Alternate Two Pipe
See Figure 4-2B

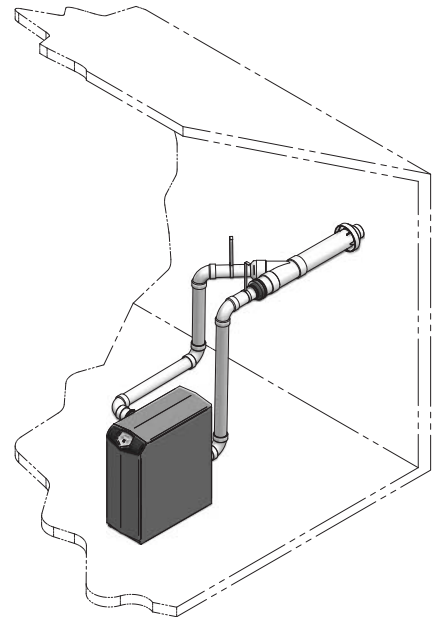

PVC/CPVC Concentric
See Figure 4-7
Models 399 - 600 Only

3 General venting (continued)

Direct venting options - Vertical Vent

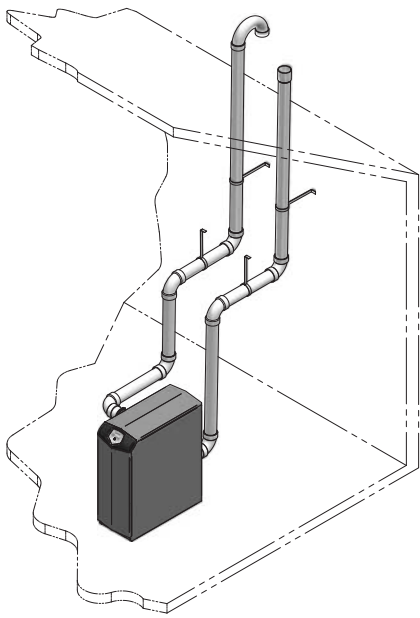

PVC/CPVC
Two Pipe
See Figure 5-1A

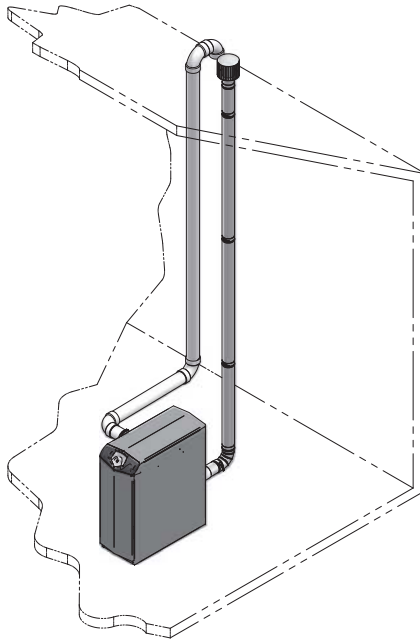

Stainless Steel
Two Pipe
See Figure 5-1B

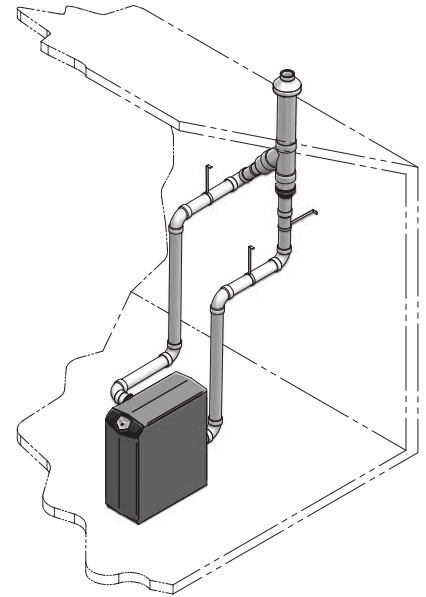

PVC/CPVC
Concentric
See Figure 5-5

Direct venting options - Vertical Vent Optional Room Air

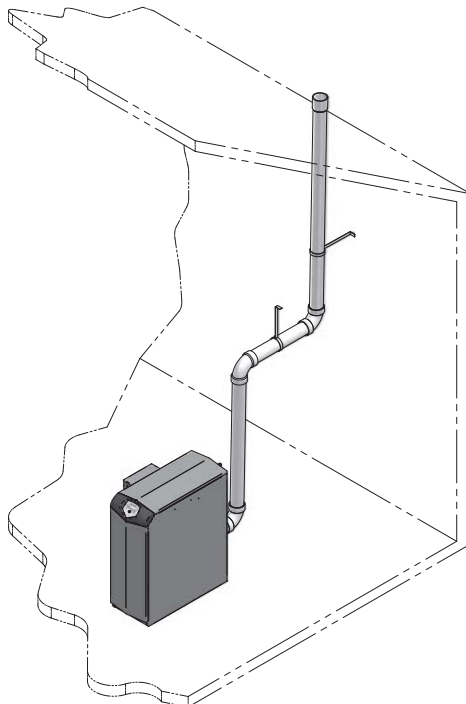

PVC/CPVC
Room Air
See Figure 5-4

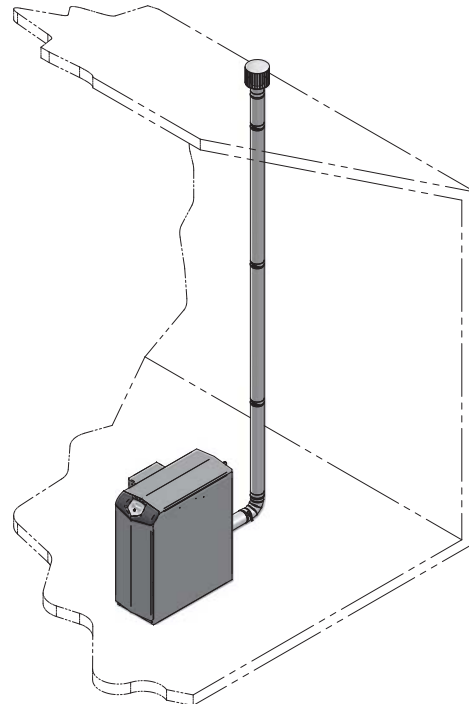

Stainless Steel
Room Air
See Figure 5-4

3 General venting

Install vent and combustion air piping

⚠ DANGER

The Knight XL must be vented and supplied with combustion and ventilation air as described in this section. Ensure the vent and air piping and the combustion air supply comply with these instructions regarding vent system, air system, and combustion air quality. See also Section 1 of this manual.

Inspect finished vent and air piping thoroughly to ensure all are airtight and comply with the instructions provided and with all requirements of applicable codes.

Failure to provide a properly installed vent and air system will cause severe personal injury or death.

NOTICE

All PVC vent pipes must be glued, properly supported, and the exhaust must be pitched a minimum of a 1/4 inch per foot back to the boiler (to allow drainage of condensate).

⚠ WARNING

This appliance requires a special venting system. The vent connection to the appliance must be made with the starter CPVC pipe section provided with the appliance. The field provided vent fittings must be cemented to the CPVC pipe section using an "All Purpose Cement" suitable for PVC and CPVC pipe. Use only the vent materials, primer, and cement specified in this manual to make the vent connections. Failure to follow this warning could result in fire, personal injury, or death.

PVC/CPVC vent piping materials

⚠ WARNING

Use only the materials listed in Table 3A below for vent pipe, and fittings. Failure to comply could result in severe personal injury, death, or substantial property damage.

NOTICE

Installation must comply with local requirements and with the National Fuel Gas Code, ANSI Z223.1 for U.S. installations or CSA B149.1 for Canadian installations.

⚠ WARNING

For closet and alcove installations, CPVC material **MUST BE** used in a closet/alcove structure. Failure to follow this warning could result in fire, personal injury, or death.

Requirements for installation in Canada

- Installations must be made with a vent pipe system certified to ULC-S636.
IPEX is an approved vent manufacturer in Canada supplying vent material listed to ULC-S636.
- The first three (3) feet of plastic vent pipe from the appliance flue outlet must be readily accessible for visual inspection.
- The components of the certified vent system must not be interchanged with other vent systems or unlisted pipe/fittings. For concentric vent installations, the inner vent tube must be replaced with field supplied certified vent material to comply with this requirement.

Table 3A PVC, Vent Pipe, and Fittings

All vent pipe materials and fittings must comply with the following:			
Item	Material	Standards for installation in:	
		United States	Canada
Vent pipe and fittings	PVC schedule 40	ANSI/ASTM D1785	CPVC and PVC venting must be ULC-S636 Certified. IPEX is an approved manufacturer in Canada supplying vent material listed to ULC-S636.
	PVC-DWV	ANSI/ASTM D2665	
	CPVC schedule 40	ANSI/ASTM F441	
Pipe cement/primer	PVC	ANSI/ASTM D2564	IPEX System 636 Cements & Primers
	CPVC	ANSI/ASTM F493	

NOTICE: DO NOT USE CELLULAR (FOAM) CORE PIPE

3 General venting *(continued)*

NOTICE

Combustion air piping to the outside **MUST BE** used. Use of combustion air from the room via louvers, plenums, or any other device is not authorized.

PVC/CPVC air intake/vent connections

1. **Combustion Air Intake Connector** (FIG.'s 3-9 and 3-10) - Used to provide combustion air directly to the unit from outdoors. A fitting is provided on the unit for final connection. Combustion air piping must be supported per guidelines listed in the National Mechanical Code, Section 305, Table 305.4 or as local codes dictate.
2. **Vent Connector** (FIG.'s 3-9 and 3-10) - Used to provide a passageway for conveying combustion gases to the outside. Transition fittings are provided with the unit for final connection. Vent piping must be supported per the National Building Code, Section 305, Table 305.4 or as local codes dictate.

Figure 3-9 Near Boiler PVC/CPVC Venting - Models 399 - 600

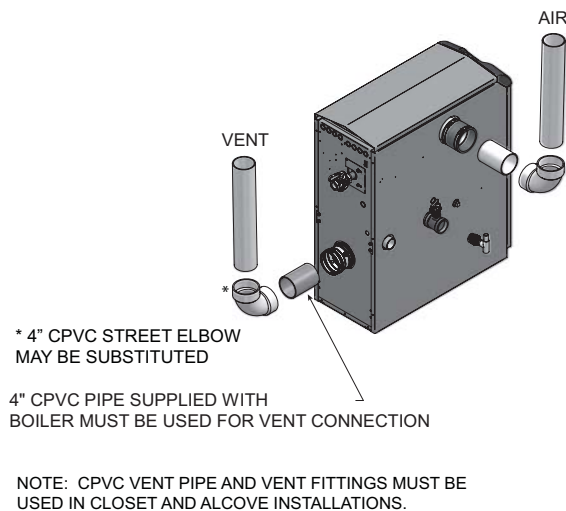
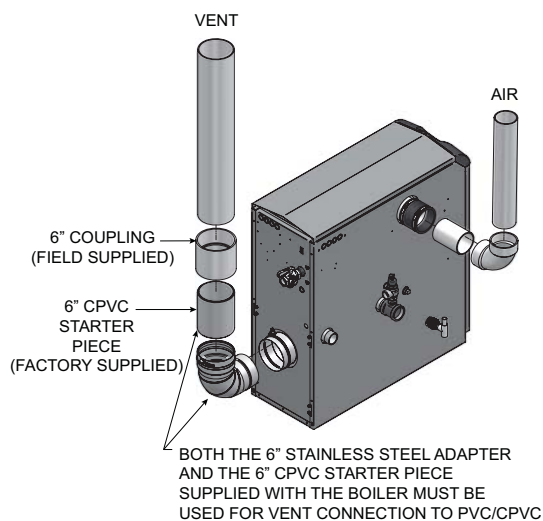

Figure 3-10 Near Boiler PVC/CPVC Venting - Models 700 - 800



Air inlet pipe materials:

The air inlet pipe(s) must be sealed. Choose acceptable combustion air inlet pipe materials from the following list:

PVC, CPVC or ABS

Dryer Vent or Sealed Flexible Duct (not recommended for rooftop air inlet)

Galvanized steel vent pipe with joints and seams sealed as specified in this section.

Type "B" double-wall vent with joints and seams sealed as specified in this section.

*Plastic pipe may require an adapter (not provided) to transition between the air inlet connection on the appliance and the plastic air inlet pipe.

WARNING

Using vent or air intake materials other than those specified, failure to properly seal all seams and joints or failure to follow vent pipe manufacturer's instructions can result in personal injury, death or property damage. Mixing of venting materials will void the warranty and certification of the appliance.

NOTICE

The use of double-wall vent or insulated material for the combustion air inlet pipe is recommended in cold climates to prevent the condensation of airborne moisture in the incoming combustion air.

Sealing of Type "B" double-wall vent material or galvanized vent pipe material used for air inlet piping on a sidewall or vertical rooftop Combustion Air Supply System:

- a. Seal all joints and seams of the air inlet pipe using either Aluminum Foil Duct Tape meeting UL Standard 723 or 181A-P or a high quality UL Listed silicone sealant such as those manufactured by Dow Corning or General Electric.
- b. Do not install seams of vent pipe on the bottom of horizontal runs.
- c. Secure all joints with a minimum of three sheet metal screws or pop rivets. Apply Aluminum Foil Duct Tape or silicone sealant to all screws or rivets installed in the vent pipe.
- d. Ensure that the air inlet pipes are properly supported.

The PVC, CPVC, or ABS air inlet pipe should be cleaned and sealed with the pipe manufacturer's recommended solvents and standard commercial pipe cement for the material used. The PVC, CPVC, ABS, Dryer Vent or Flex Duct air inlet pipe should use a silicone sealant to ensure a proper seal at the appliance connection and the air inlet cap connection. Dryer vent or flex duct should use a screw type clamp to seal the vent to the appliance air inlet and the air inlet cap. Proper sealing of the air inlet pipe ensures that combustion air will be free of contaminants and supplied in proper volume.

3 General venting

When a sidewall or vertical rooftop combustion air supply system is disconnected for any reason, the air inlet pipe must be resealed to ensure that combustion air will be free of contaminants and supplied in proper volume.

⚠ DANGER Failure to properly seal all joints and seams as required in the air inlet piping may result in flue gas recirculation, spillage of flue products and carbon monoxide emissions causing severe personal injury or death.

Stainless steel vent

This product has been approved for use with stainless steel FasNseal vent systems manufactured by Protech.

⚠ WARNING Use only the materials, vent systems, and terminations listed in Table 3B. DO NOT mix vent systems. Failure to comply could result in severe personal injury, death, or substantial property damage.

NOTICE Installations must comply with local codes. Stainless steel vent systems must be listed as a UL-1738 approved system for the United States and a ULC-S636 approved system for Canada.

NOTICE Installation of a stainless steel vent system should adhere to the installation instructions supplied with the vent system.

NOTICE The installer must use a specific vent starter adapter supplied by the vent manufacturer to adapt to different vent systems. See Table 3B for approved vent adapters.

Stainless steel air intake/vent connections

1. **Combustion Air Intake Connector** (FIG.'s 3-11 and 3-12) - Used to provide combustion air directly to the unit from outdoors. A fitting is provided on the unit for final connection. Combustion air piping must be supported per guidelines listed in the National Mechanical Code, Section 305, Table 305.4 or as local codes dictate.
2. **Vent Connector** (FIG.'s 3-11 and 3-12) - Used to provide a passageway for conveying combustion gases to the outside. A transition fitting is provided on the unit for final connection. Vent piping must be supported per the National Building Code, Section 305, Table 305.4 or as local codes dictate.

Figure 3-11 Near Boiler Stainless Steel Venting Models 399 - 600

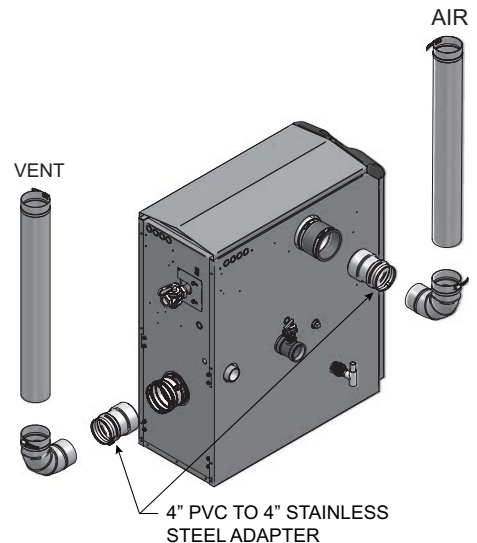

Figure 3-12 Near Boiler Stainless Steel Venting Models 700 - 800

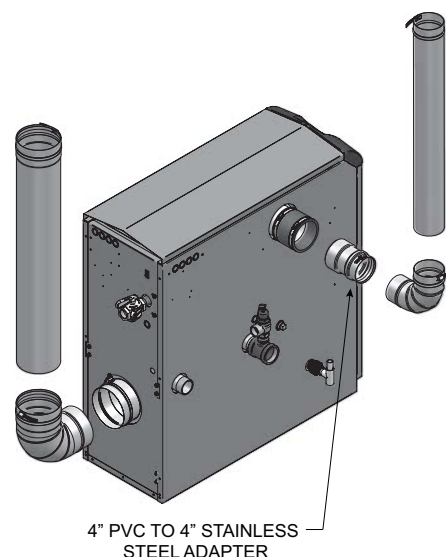

Table 3B Approved Stainless Steel Terminations and Adapters

Model	Description	Lochinvar Part Number	Vendor and Part Number
399 - 600	4" SS Adapter** (2)	MSC2761	FasNseal - F303759
	4" Flue Termination**	MSC2198	FasNseal - FSBS4
	4" Air Intake Termination**	MSC2764	FasNseal - FSAIH04
700 - 800	4" SS Adapter**	MSC2761	FasNseal - F303759
	4" Air Intake Termination**	MSC2764	FasNseal - FSAIH04
	6" Flue Termination**	MSC2763	FasNseal - FSBS6
*Note: Part is supplied with the unit.			
**Note: Part is supplied in the Kit.			

Table 3C Stainless Steel Vent Termination Kits

Model	Kit Number
399 - 600	KIT3136
700 - 800	KIT3137

3 General venting *(continued)*

The Knight XL uses model specific combustion air intake and vent piping sizes as detailed in Table 3D below.

Table 3D Air Intake/Vent Piping Sizes

Model	Air Intake	Vent
399 - 600	4 inches (102 mm)	4 inches (102 mm)
700 - 800	4 inches (102 mm)	6 inches (152 mm)

NOTICE

Increasing or decreasing combustion air or vent piping is not authorized.

Minimum / Maximum allowable combustion air and vent piping lengths are as follows:

Combustion Air = 12 equivalent feet (3.7 m) minimum / 100 equivalent feet (30.5 m) maximum

Vent = 12 equivalent feet (3.7 m) minimum / 100 equivalent feet (30.5 m) maximum

When determining equivalent combustion air and vent length, add 5 feet (1.5m) for each 90° elbow and 3 feet (.9 m) for each 45° elbow.

EXAMPLE: 20 feet (6 m) of PVC pipe + (3) 90° elbows + (3) 45° elbows + (1) concentric vent kit (CVK3007) = 49 equivalent feet (15 m) of piping.

NOTICE

The appliance output rating will reduce by up to 1.5% for each 25 feet (68 m) of vent length.

Table 3E Concentric Vent Kit Equivalent Vent Lengths

Model	Kit Number	Equivalent Vent Length
399	CVK3007	5 Feet (1.5 m)
500	CVK3007	30 Feet (9 m)
600	CVK3007	30 Feet (9 m)

Removing from existing vent

Follow the instructions in Section 1, page 11 of this manual when removing a boiler from an existing vent system.

Vent and air piping

Vent and air system:

NOTICE

Installation must comply with local requirements and with the National Fuel Gas Code, ANSI Z223.1 for U.S. installations or CSA B149.1 for Canadian installations.

You must also install air piping from outside to the boiler air intake adapter. The resultant installation is direct vent (sealed combustion).

You may use any of the vent/air piping methods covered in this manual. Do not attempt to install the Knight XL using any other means.

WARNING

DO NOT mix components from different systems. The vent system could fail, causing leakage of flue products into the living space. Use only PVC or CPVC pipe and fittings, with primer and cement specifically designed for the material used.

Vent, air piping and termination:

The Knight XL vent and air piping can be installed through the roof or through a sidewall. Follow the procedures in this manual for the method chosen. Refer to the information in this manual to determine acceptable vent and air piping length.

Air contamination

Pool and laundry products and common household and hobby products often contain fluorine or chlorine compounds. When these chemicals pass through the boiler, they can form strong acids. The acid can eat through the boiler wall, causing serious damage and presenting a possible threat of flue gas spillage or boiler water leakage into the building.

Please read the information given in Table 1A, page 11, listing contaminants and areas likely to contain them. If contaminating chemicals will be present near the location of the boiler combustion air inlet, have your installer pipe the boiler combustion air and vent to another location, per this manual.

WARNING

If the boiler combustion air inlet is located in a laundry room or pool facility, for example, these areas will always contain hazardous contaminants.

WARNING

To prevent the potential of severe personal injury or death, check for areas and products listed in Table 1A, page 11 before installing the boiler or air inlet piping.

If contaminants are found, you **MUST**:

- Remove products permanently.
- OR—
- Relocate air inlet and vent terminations to other areas.

4 Sidewall direct venting

Vent/air termination – sidewall

⚠ WARNING Follow instructions below when determining vent location to avoid possibility of severe personal injury, death, or substantial property damage.

⚠ WARNING A gas vent extending through an exterior wall shall not terminate adjacent to a wall or below building extensions such as eaves, parapets, balconies, or decks. Failure to comply could result in severe personal injury, death, or substantial property damage.

⚠ WARNING Do not connect any other appliance to the vent pipe or multiple boilers to a common vent pipe. Failure to comply could result in severe personal injury, death, or substantial property damage.

NOTICE Installation must comply with local requirements and with the National Fuel Gas Code, ANSI Z223.1 for U.S. installations or CSA B149.1 for Canadian installations.

Determine location

Locate the vent/air terminations using the following guidelines:

- The total length of piping for vent or air must not exceed the limits given in the General Venting Section on page 19 of this manual.
- You must consider the surroundings when terminating the vent and air:
 - Position the vent termination where vapors will not damage nearby shrubs, plants or air conditioning equipment or be objectionable.
 - The flue products will form a noticeable plume as they condense in cold air. Avoid areas where the plume could obstruct window views.
 - Prevailing winds could cause freezing of condensate and water/ice buildup where flue products impinge on building surfaces or plants.
 - Avoid possibility of accidental contact of flue products with people or pets.
 - Do not locate the terminations where wind eddies could affect performance or cause recirculation, such as inside building corners, near adjacent buildings or surfaces, window wells, stairwells, alcoves, courtyards, or other recessed areas.

⚠ WARNING Sidewall vent and air inlet terminations must terminate in the same pressure zone.

- Do not terminate above any door or window. Condensate can freeze, causing ice formations.
- Locate or guard vent to prevent condensate damage to exterior finishes.

Figure 4-1A PVC/CPVC Sidewall Termination of Air and Vent

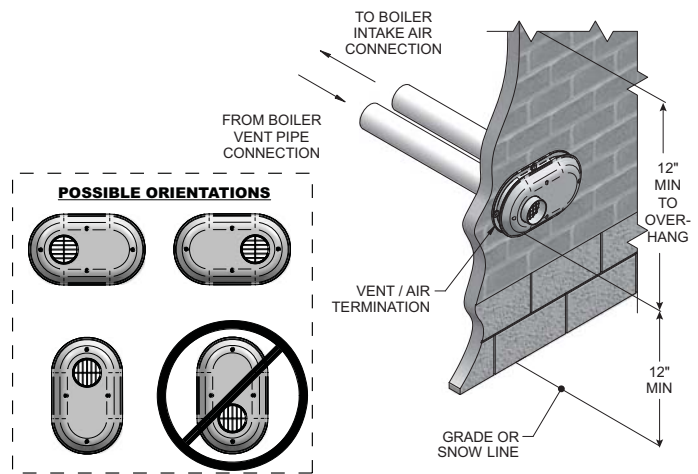

Table 4A Sidewall Vent Kits

Model	Kit Number	Vent Size
399 - 600	KIT30046	4 inch vent
700 - 800	KIT30048	6 inch vent

If using the alternate sidewall termination:

- The air piping must terminate in a down-turned elbow as shown in FIG. 4-1B. This arrangement avoids recirculation of flue products into the combustion air stream.
- The vent piping must terminate in an elbow pointed outward or away from the air inlet, as shown in FIG. 4-1B.

⚠ WARNING Do not exceed the maximum lengths of the outside vent piping shown in FIG. 4-1B. Excessive length exposed to the outside could cause freezing of condensate in the vent pipe, resulting in potential boiler shutdown.

Figure 4-1B Alternate PVC/CPVC Sidewall Termination of Air and Vent w/Field Supplied Fittings

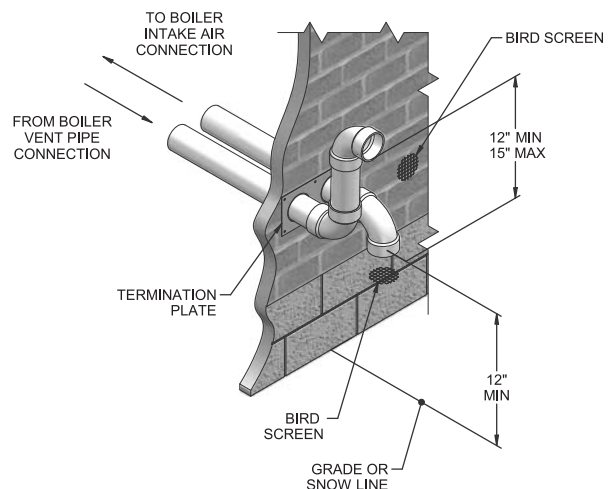

4 Sidewall direct venting *(continued)*

Vent/air termination – sidewall

Figure 4-1C Alternate Vent Termination - Typical Stainless Steel Sidewall Termination of Air and Vent Models 399 - 600 w/Field Supplied Fittings

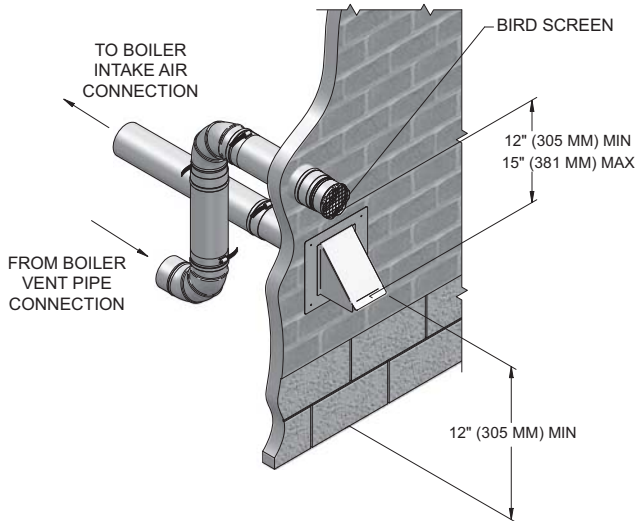

Figure 4-2A Alternate PVC/CPVC Sidewall Termination Models 399 - 800 w/Field Supplied Fittings

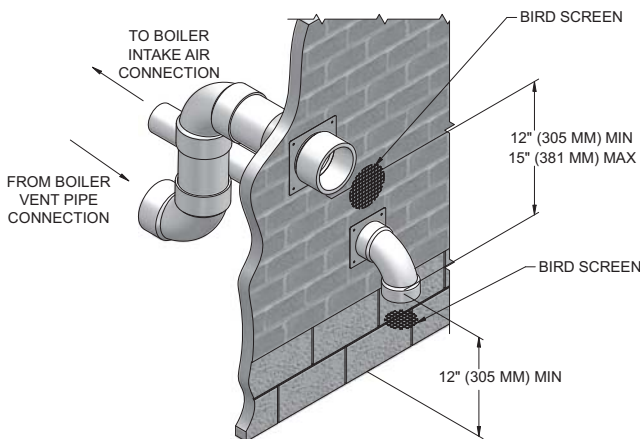
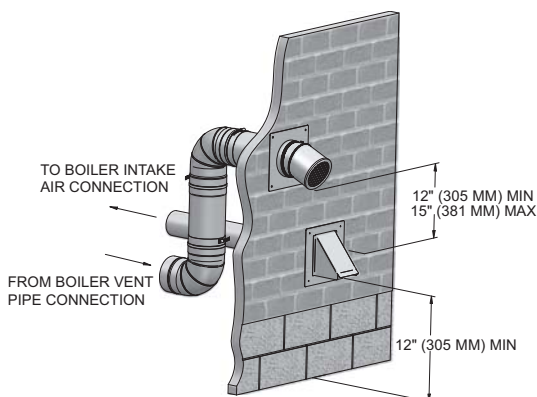

Figure 4-2B Alternate Stainless Steel Sidewall Termination Models 700 - 800 w/Field Supplied Fittings



NOTICE PVC/CPVC or ABS is acceptable air inlet pipe material.

5. Maintain clearances as shown in FIG.'s 4-1A thru 4-4B, pages 20 thru 22. Also maintain the following:
 - a. Vent must terminate:
 - At least 6 feet (1.8 m) from adjacent walls.
 - No closer than 12 inches (305 mm) below roof overhang.
 - At least 7 feet (2.1 m) above any public walkway.
 - At least 3 feet (.9 m) above any forced air intake within 10 feet (3 m).
 - No closer than 12 inches (305 mm) below or horizontally from any door or window or any other gravity air inlet.
 - b. Air inlet must terminate at least 12 inches (305 mm) above grade or snow line; at least 12 inches (305 mm) below the vent termination (FIG. 4-1B); and the vent pipe must not extend more than 24 inches (610 mm) vertically outside the building.
 - c. Do not terminate closer than 4 feet (1.2 m) horizontally from any electric meter, gas meter, regulator, relief valve, or other equipment. Never terminate above or below any of these within 4 feet (1.2 m) horizontally.
6. Locate terminations so they are not likely to be damaged by foreign objects, such as stones or balls, or subject to buildup of leaves or sediment.

Figure 4-3A Clearance to Gravity Air Inlets

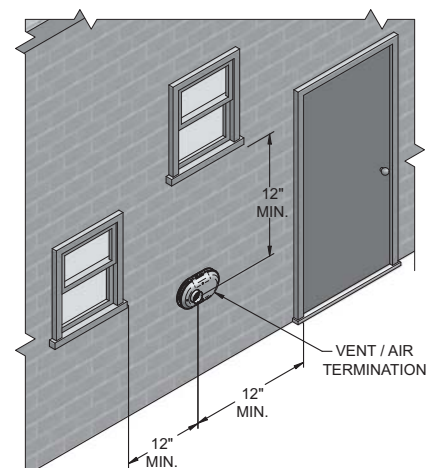

4 Sidewall direct venting

Vent/air termination – sidewall

Figure 4-3B Alternate Clearance to Gravity Air Inlets w/Field Supplied Fittings

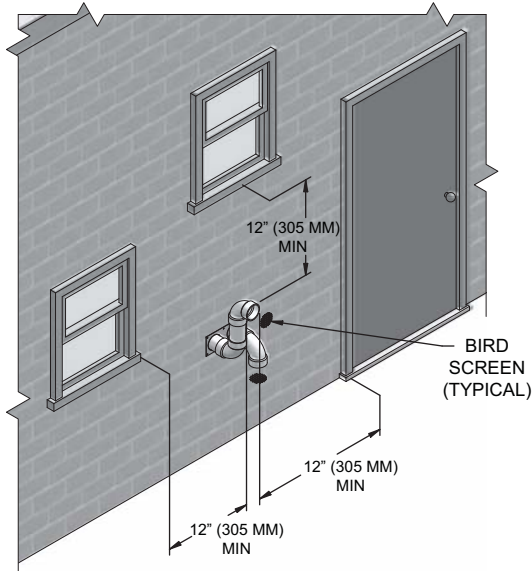

Figure 4-4A Clearance to Forced Air Inlets

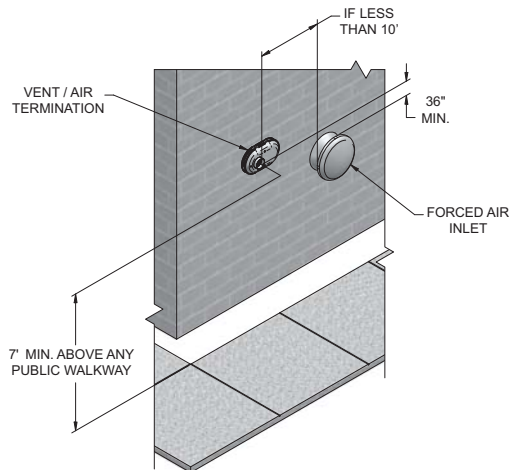
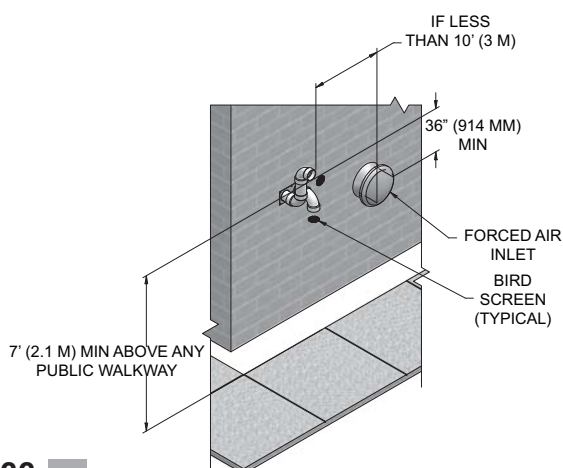

Figure 4-4B Alternate Clearance to Forced Air Inlets w/Field Supplied Fittings



Prepare wall penetrations

1. Use the factory supplied wall plate as a template to locate the vent and air intake holes and mounting holes.

Air pipe penetration:

- a. Cut a hole for the air pipe. Size the air pipe hole as close as desired to the air pipe outside diameter.

Vent pipe penetration:

- a. Cut a hole for the vent pipe. For either combustible or noncombustible construction, size the vent pipe hole with at least a 1/2 inch clearance around the vent pipe outer diameter:

- 5½ inch hole (140 mm) hole for 4 inch (102 mm) vent pipe
- 7½ inch hole (191 mm) hole for 6 inch (152 mm) vent pipe

Drill 3/16" diameter holes for inserting the plastic anchors into the wall.

2. Install the vent and air intake piping through the wall into the vent plate openings. Seal all gaps between the pipes and wall. Use RTV silicone sealant to seal the air pipe. Use the cement/primer listed in Table 3A on page 16 to seal the vent pipe.
3. Mount and secure the vent plate to the wall using stainless steel screws. Seal around the plate to the wall assuring no air gaps.
4. Assemble the vent cap to the vent plate (see FIG. 4-4A). Insert the stainless steel screws into the vent cap screw hole openings and securely attach the vent cap to the vent plate.
5. Seal all wall cavities.

Figure 4-5A Sidewall Termination Assembly

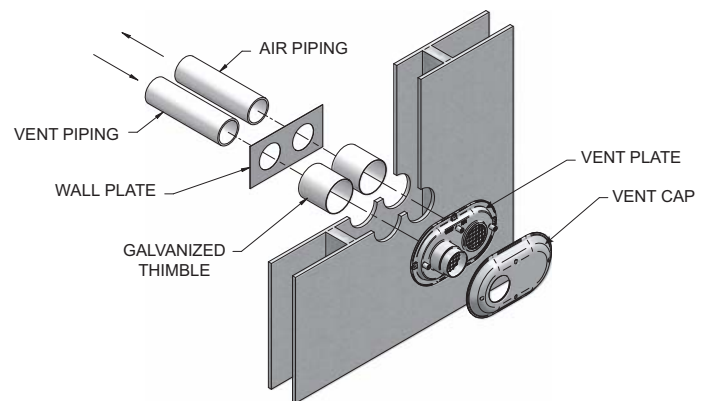

4 Sidewall direct venting *(continued)*

Prepare wall penetrations (Alternate - Field Supplied Option) Multiple vent/air terminations

1. Air pipe penetration:
 - a. Cut a hole for the air pipe. Size the air pipe hole as close as desired to the air pipe outside diameter.
2. Vent pipe penetration:
 - a. Cut a hole for the vent pipe. For either combustible or noncombustible construction, size the vent pipe hole with at least a 1/2 inch clearance around the vent pipe outer diameter:
 - 5½ inch hole (140 mm) hole for 4 inch (102 mm) vent pipe
 - 7½ inch hole (191 mm) hole for 6 inch (152 mm) vent pipe
 - b. Insert a galvanized metal thimble in the vent pipe hole as shown in FIG. 4-5B.
3. Use a sidewall termination plate as a template for correct location of hole centers.
4. Follow all local codes for isolation of vent pipe when passing through floors or walls.
5. Seal exterior openings thoroughly with exterior caulk.

Figure 4-5B A Typical Sidewall Termination Assembly - Models 399 - 800 PVC/CPVC or Stainless Steel

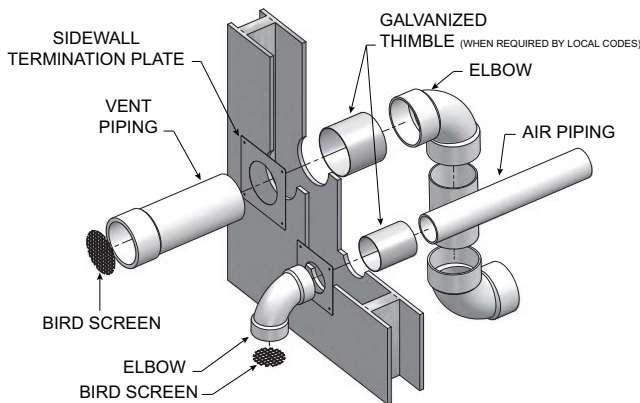

Termination and fittings

1. Prepare the vent termination elbow and the air termination elbow (FIG. 4-5B) by inserting the bird screens provided with the boiler.
2. When completed, the air termination coupling must be oriented at least 12 inches (305 mm) below the vent termination and at least 12 inches (305 mm) above grade or snow line as shown in FIG. 4-1A, page 20.
3. Maintain the required dimensions of the finished termination piping as shown in FIG. 4-1A, page 20.
4. Do not extend exposed vent pipe outside of building more than shown in this document. Condensate could freeze and block vent pipe.
5. PVC/CPVC terminations are designed to accommodate any wall thickness of standard constructions per the directions found in this manual.
6. Stainless steel terminations are designed to penetrate walls with a thickness up to 9.25 inches of standard construction.

1. When terminating multiple Knight XL's terminate each vent/air connection as described in this manual (FIG. 4-6A).

WARNING

All vent pipes and air inlets must terminate at the same height to avoid possibility of severe personal injury, death, or substantial property damage.

2. Place wall penetrations to obtain minimum clearance of 12 inches (305 mm) between vent pipe and adjacent air inlet elbow, as shown in FIG. 4-6A for U.S. installations. For Canadian installations, provide clearances required by CSA B149.1 Installation Code.
3. The air inlet of a Knight XL is part of a direct vent connection. It is not classified as a forced air intake with regard to spacing from adjacent boiler vents.

Figure 4-6A Multiple Vent Terminations (must also comply with Figure 4-1A)

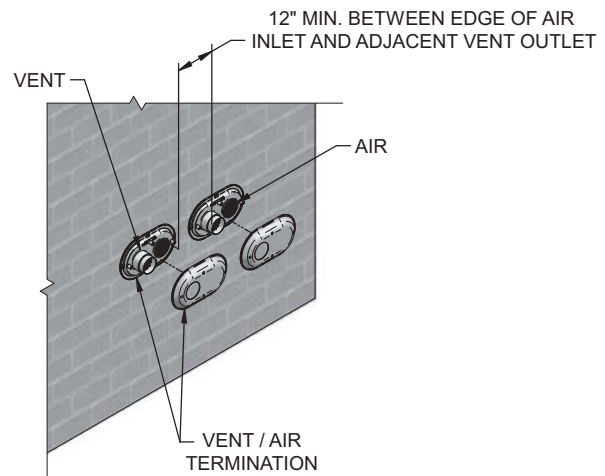
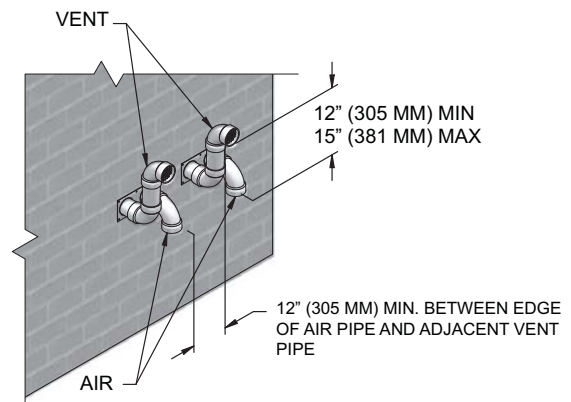

Figure 4-6B Alternate Multiple Vent Terminations w/Field Supplied Fittings (must also comply with Figure 4-1B)



4 Sidewall direct venting

Sidewall termination – optional concentric vent: Models 399 - 600 Only

Description and usage

Lochinvar offers an optional concentric combustion air and vent pipe termination kit (#CVK3007 for 4" (102 mm) diameter - Models 399 - 600). Both combustion air and vent pipes must attach to the termination kit. The termination kit must terminate outside the structure and must be installed as shown below in FIG. 4-7.

Field supplied pipe and fittings are required to complete the installation.

The required combustion vent pipe materials are listed in Table 3A, on page 16 of this manual.

Figure 4-7 Concentric Sidewall Termination - Models 399 - 600

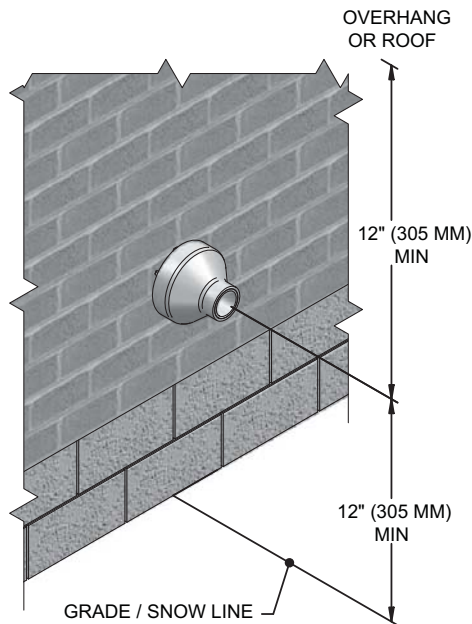

Sidewall termination installation

1. Determine the best location for the termination kit (see FIG. 4-7).
2. The total length of piping for vent or air must not exceed the limits given in the General Venting section on page 19 of this manual.

3. You must consider the surroundings when terminating the vent and air:
 - a. Position the vent termination where vapors will not damage nearby shrubs, plants or air conditioning equipment or be objectionable.
 - b. The flue products will form a noticeable plume as they condense in cold air. Avoid areas where the plume could obstruct window views.
 - c. Prevailing winds could cause freezing of condensate and water/ice buildup where flue products impinge on building surfaces or plants.
 - d. Avoid possibility of accidental contact of flue products with people or pets.
 - f. Do not terminate above any door or window. Condensate can freeze, causing ice formations.
 - g. Locate or guard vent to prevent condensate damage to exterior finishes.

Figure 4-8 Kit Contents_CVK3007 - Models 399 - 600

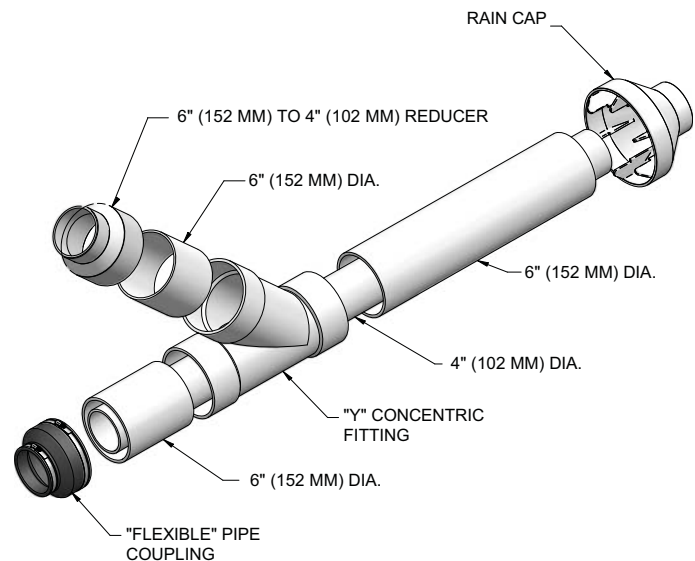

4. Cut one (1) hole (7 inch (178 mm) diameter for #CVK3007 installations into the structure to install the termination kit.
5. Partially assemble the concentric vent termination kit. Clean and cement using the procedures found in these instructions.
 - a. Cement the Y concentric fitting to the larger kit pipe (FIG. 4-8).
 - b. Cement the rain cap to the smaller diameter kit pipe (FIG. 4-8).

4 Sidewall direct venting *(continued)*

Sidewall termination – optional concentric vent: Models 399 - 600 Only

Figure 4-9 Concentric Vent Dimensional Drawing - Models 399 - 600

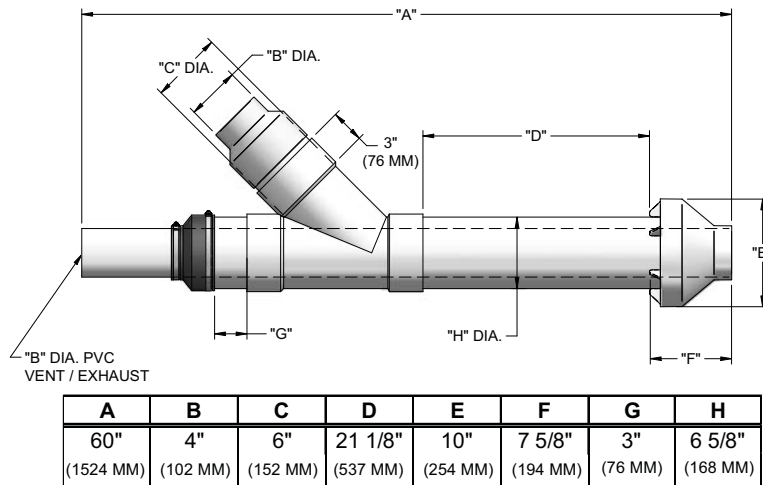

NOTICE

Instead of cementing the smaller pipe to the rain cap, a field-supplied stainless steel screw may be used to secure the two (2) components together when field disassembly is desired for cleaning (see FIG. 4-10).

⚠ WARNING

When using the alternate screw assembly method, drill a clearance hole in the rain cap and a pilot hole in the vent pipe for the screw size being used. Failure to drill adequate holes may cause cracking of PVC components, allowing combustion products to be recirculated. Failure to follow this warning could result in personal injury or death.

⚠ WARNING

Do not operate the appliance with the rain cap removed or recirculation of combustion products may occur. Water may also collect inside the larger combustion air pipe and flow to the burner enclosure. Failure to follow this warning could result in product damage or improper operation, personal injury, or death.

6. Install the Y concentric fitting and pipe assembly through the structure's hole from an inside wall.

NOTICE

Do not allow insulation or other materials to accumulate inside the pipe assembly when installing through the hole.

7. Install the rain cap and small diameter pipe assembly into the Y concentric fitting and large pipe assembly from an outside wall. Ensure small diameter pipe is fastened tightly into the rubber adapter for #CVK3007 installations.
8. Secure the assembly to the structure as shown in FIG. 4-11 using field-supplied metal strapping or equivalent support material.

NOTICE

Ensure termination location clearance dimensions are as shown in FIG. 4-7.

NOTICE

If assembly needs to be extended to allow sidewall thickness requirement, the two (2) pipes supplied in the kit may be replaced by using the same diameter, field-supplied standard schedule 40 PVC for CVK3007. Do not extend dimension D* more than 60 inches (1524 mm) (see FIG. 4-9).

NOTICE

If assembly depth needs to be reduced, dimension D can be as short as possible.

Figure 4-10 Rain Cap to Vent Pipe Alternate Assembly

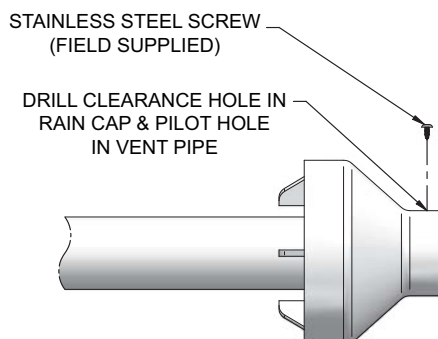

4 Sidewall direct venting

Sidewall termination – optional concentric vent: Models 399 - 600 Only

Figure 4-11 Concentric Vent Sidewall Attachment

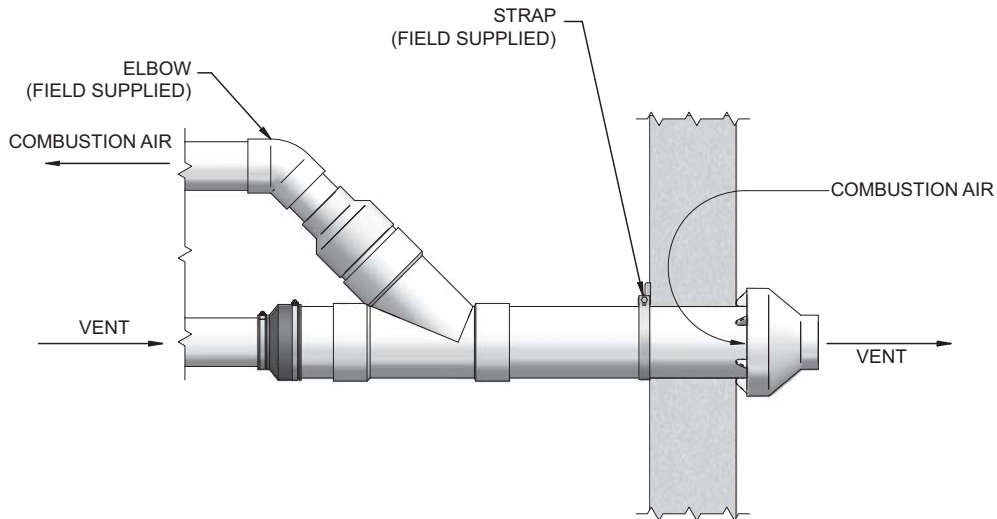

CAUTION

DO NOT use field-supplied couplings to extend pipes. Airflow restriction will occur and may cause intermittent operation.

9. Cement appliance combustion air and vent pipes to the concentric vent termination assembly. See FIG. 4-11 for proper pipe attachment.
10. Operate the appliance one (1) heat cycle to ensure combustion air and vent pipes are properly connected to the concentric vent termination connections.

Multiventing sidewall terminations

When two (2) or more direct vent appliances are vented near each other, each appliance must be individually vented (see FIG. 4-12). NEVER common vent or breach vent this appliance. When two (2) or more direct vent appliances are vented near each other, two (2) vent terminations may be installed as shown in FIG. 4-12. The next two (2) terminations must be at least 36 inches (914 mm) away from the first two (2) terminations. It is important that vent terminations be made as shown to avoid recirculation of flue gases. Dimension A in FIG. 4-12 represents the distance between pipes or rain shields, as touching or a 2 inch (51 mm) maximum separation.

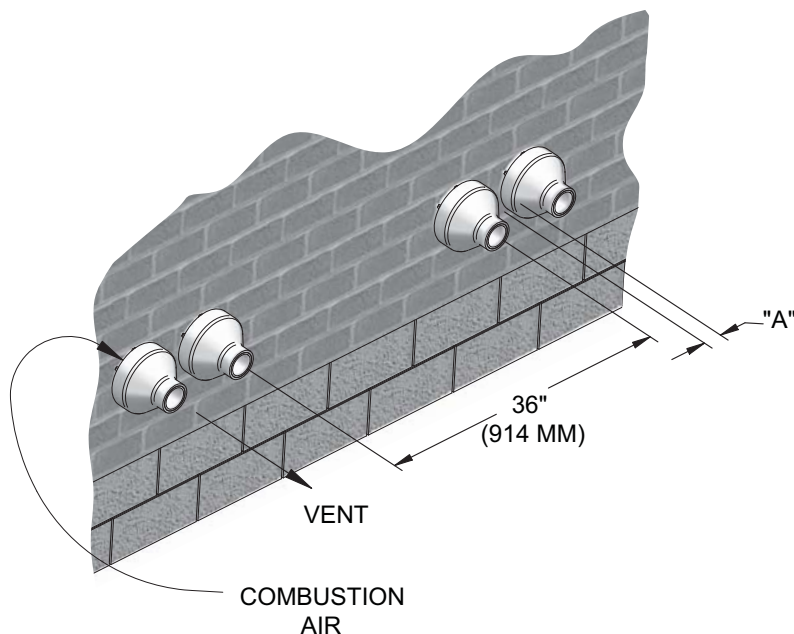

Figure 4-12 Concentric Vent and Combustion Air Termination Dimension A as Touching or 2 inches (51 mm) Maximum Separation

5 Vertical direct venting

Vent/air termination – vertical

⚠ WARNING Follow instructions below when determining vent location to avoid possibility of severe personal injury, death or substantial property damage.

⚠ WARNING Do not connect any other appliance to the vent pipe or multiple boilers to a common vent pipe. Failure to comply could result in severe personal injury, death, or substantial property damage.

NOTICE Installation must comply with local requirements and with the National Fuel Gas Code, ANSI Z223.1 for U.S. installations or CSA B149.1 for Canadian installations.

Determine location

Locate the vent/air terminations using the following guidelines:

1. The total length of piping for vent or air must not exceed the limits given in the General Venting Section on page 19 of this manual.
2. The vent must terminate at least 3 feet above the highest place in which the vent penetrates the roof and at least 2 feet above any part of a building within 10 horizontal feet.
3. The air piping must terminate in a down-turned 180° return pipe no further than 2 feet (.6 m) from the center of the vent pipe. This placement avoids recirculation of flue products into the combustion air stream.
4. The vent piping must terminate in an up-turned coupling as shown in FIG. 5-1A. The top of the coupling must be at least 1 foot above the air intake. When the vent termination uses a rain cap as illustrated in FIG. 5-1B maintain at least 36" (914 mm) above the air inlet. The air inlet pipe and vent pipe can be located in any desired position on the roof, but must always be no further than 2 feet (.6 m) apart and with the vent termination at least 1 foot above the air intake.

⚠ WARNING Rooftop vent and air inlet terminations must terminate in the same pressure zone.

Figure 5-1A PVC/CPVC Vertical Termination of Air and Vent

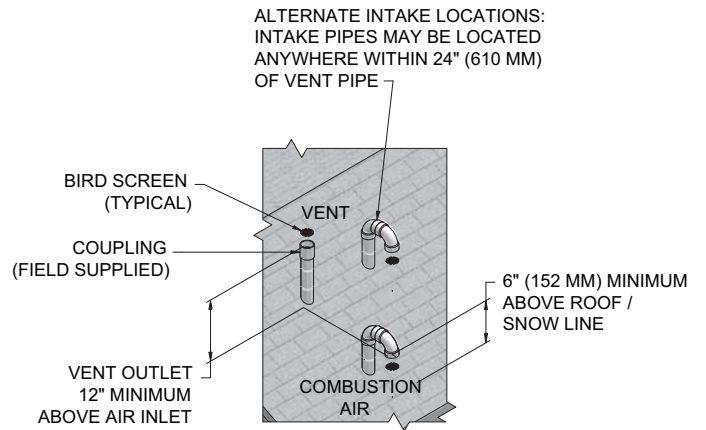
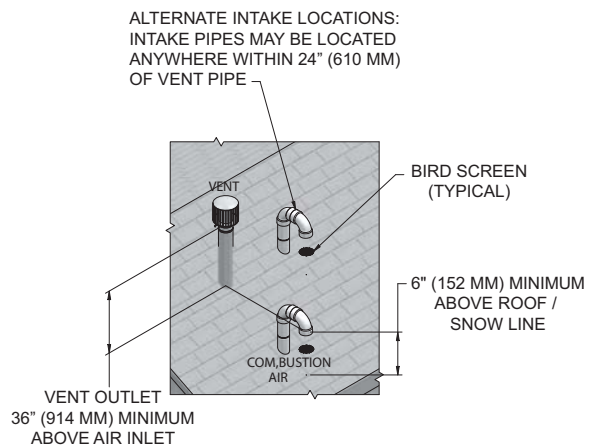

Figure 5-1B Stainless Steel Vertical Termination of Air and Vent



5. Locate terminations so they are not likely to be damaged by foreign objects, such as stones or balls, or subject to buildup of leaves or sediment.

5 Vertical direct venting

Vent/air termination – vertical

Prepare roof penetrations

- Air pipe penetration:
 - Cut a hole for the air pipe. Size the air pipe hole as close as desired to the air pipe outside diameter.
- Vent pipe penetration:
 - Cut a hole for the vent pipe. For either combustible or noncombustible construction, size the vent pipe hole with at least a 1/2 inch clearance around the vent pipe outer diameter:
 - 5½ inch (140 mm) hole for 4 inch (102 mm) vent pipe
 - 7½ inch (191 mm) hole for 6 inch (152 mm) vent pipe
 - Insert a galvanized metal thimble in the vent pipe hole (when required by local codes).
- Space the air and vent holes to provide the minimum spacing shown in FIG.'s 5-1A and 5-1B, page 27.
- Follow all local codes for isolation of vent pipe when passing through floors, ceilings, and roofs.
- Provide flashing and sealing boots sized for the vent pipe and air pipe.

Termination and fittings

- Prepare the vent termination coupling and the air termination elbow (FIG.'s 5-1A and 5-1B) by inserting the bird screens provided with the boiler.
- The air piping must terminate in a down-turned 180° return bend as shown in FIG.'s 5-1A and 5-1B. Locate the air inlet pipe no further than 2 feet (.6 m) from the center of the vent pipe. This placement avoids recirculation of flue products into the combustion air stream.
- The vent piping must terminate in an up-turned coupling as shown in FIG. 5-1A. The top of the coupling must be at least 1 foot (.3 m) above the air intake. When the vent termination uses a rain cap as illustrated in FIG. 5-1B maintain at least 36" (914 mm) above the air inlet. The air inlet pipe and vent pipe can be located in any desired position on the roof, but must always be no further than 2 feet (.6 m) apart and with the vent termination at least 1 foot (.3 m) above the air intake.
- Maintain the required dimensions of the finished termination piping as shown in FIG.'s 5-1A and 5-1B.
- Do not extend exposed vent pipe outside of building more than shown in this document. Condensate could freeze and block vent pipe.

Multiple vent/air terminations

- When terminating multiple Knight XL boilers, terminate each vent/air connection as described in this manual (FIG. 5-2).

⚠ WARNING

Terminate all vent pipes at the same height and all air pipes at the same height to avoid recirculation of flue products and the possibility of severe personal injury, death, or substantial property damage.

- Place roof penetrations to obtain minimum clearance of 12 inches (305 mm) between edge of air intake elbow and adjacent vent pipe of another boiler for U.S. installations (see FIG. 5-2). For Canadian installations, provide clearances required by CSA B149.1 Installation Code.
- The air inlet of a Knight XL boiler is part of a direct vent connection. It is not classified as a forced air intake with regard to spacing from adjacent boiler vents.

Figure 5-2 Vertical Terminations with Multiple Boilers

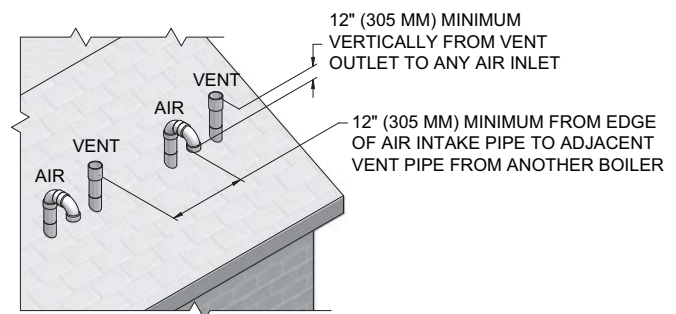
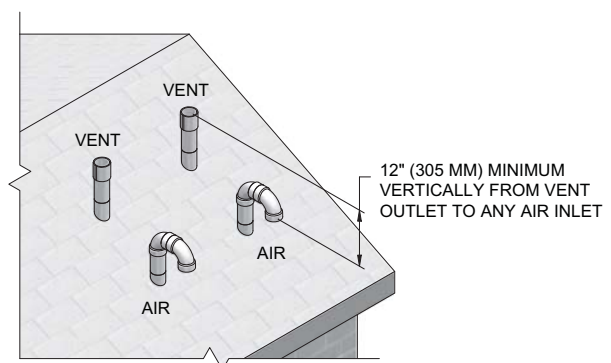

Figure 5-3 Alternate Vertical Terminations with Multiple Boilers



5 Vertical direct venting *(continued)*

Vertical termination – optional room air

The Knight XL may be installed with a single pipe carrying the flue products to the outside while using combustion air from the equipment room. The vent pipe may terminate vertically above the roof line in a conventional vent manner (see FIG. 5-4).

Follow the requirements in the General Venting and Vertical Direct Venting sections for vent material specifications, vent length requirements, and vent termination requirements.

⚠ WARNING

When utilizing the single pipe method, provisions for combustion and ventilation air must be in accordance with Air for Combustion and Ventilation, of the latest edition of the National Fuel Gas Code, ANSI Z223.1, in Canada, the latest edition of CGA Standard B149 Installation Code for Gas Burning Appliances and Equipment, or applicable provisions of the local building codes.

The equipment room **MUST** be provided with properly sized openings to assure adequate combustion air and proper ventilation.

Lochinvar offers an optional room air kit. The room air filter box must be installed over the air intake on the left side of the unit as shown in FIG. 5-4.

- Vent system and terminations must comply with the standard venting instructions set forth in this manual.
- The total length of vent pipe must not exceed the limits given in the General Venting section on page 19 of this manual.
- The air filter box uses an 12 x 12, one inch filter (see Table 5A). This air filter is provided to help ensure clean air is used for the combustion process. Check this filter every month and replace when it becomes dirty.

Figure 5-4 Optional Room Air Filter Box

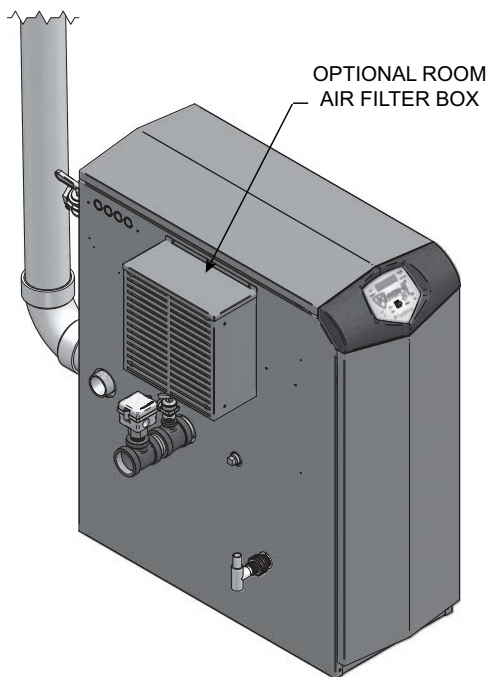

Table 5A Optional Room Air Kit

Model	Kit Number
399 - 800	KIT30022

5 Vertical direct venting

Vertical termination – optional concentric vent: Models 399 - 600 Only

Description and usage

Lochinvar offers an optional concentric combustion air and vent pipe termination kit. Both combustion air and vent pipes must attach to the termination kit. The termination kit must terminate outside the structure and must be installed as shown in FIG. 5-5.

Field supplied pipe and fittings are required to complete the installation.

The required combustion vent pipe fittings are listed in Table 3A, on page 16 of this manual.

Vertical termination installation

1. Determine the best location for the termination kit (see FIG. 5-5).
2. The total length of piping for vent or air must not exceed the limits given in the General Venting Section on page 19 of this manual.
3. You must consider the surroundings when terminating the vent and air:
 - a. Position the vent termination where vapors will not damage nearby shrubs, plants, or air conditioning equipment or be objectionable.
 - b. The flue products will form a noticeable plume as they condense in cold air. Avoid areas where the plume could obstruct window views.
 - c. Prevailing winds could cause freezing of condensate and water/ice buildup where flue products impinge on building surfaces or plants.
 - d. Avoid possibility of accidental contact of flue products with people or pets.
 - e. Do not locate the terminations where wind eddies could affect performance or cause recirculation, such as inside building corners, near adjacent buildings or surfaces, window wells, stairwells, alcoves, courtyards, or other recessed areas.
 - f. Do not terminate above any door or window. Condensate can freeze, causing ice formations.
 - g. Locate or guard vent to prevent condensate damage to exterior finishes.
 - h. Do not attach a U-Bent to the rain cap. Doing so could cause recirculation (see FIG. 5-6).
4. Cut one (1) hole (7 inch (178 mm) diameter for #CVK3007 installations) into the structure to install the termination kit.
5. Partially assemble the concentric vent termination kit. Clean and cement following the cleaning procedures in these instructions.
 - a. Cement the Y concentric fitting to the larger diameter kit pipe (see FIG. 4-8, page 24).
 - b. Cement rain cap to the smaller diameter kit pipe (see FIG. 4-8, page 24).

Figure 5-5 Concentric Vertical Termination

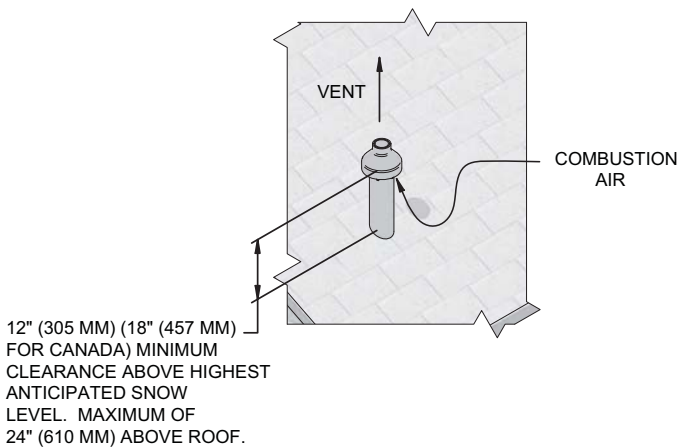

Figure 5-6 Do Not Install U-Bent to Rain Cap



NOTICE

Instead of cementing the smaller pipe to the rain cap, a field supplied stainless steel screw may be used to secure the two (2) components together when field disassembly is desired for cleaning (see FIG. 4-10, page 25).

WARNING

When using the alternate screw assembly method, drill a clearance hole in the rain cap and a pilot hole in the vent pipe for the screw size being used. Failure to drill adequate holes may cause cracking of PVC components, allowing combustion products to be recirculated. Failure to follow this warning could result in personal injury or death.

5 Vertical direct venting *(continued)*

Vertical termination – optional concentric vent: Models 399 - 600 Only

⚠ WARNING

Do not operate the appliance with the rain cap removed or recirculation of combustion products may occur. Water may also collect inside the larger combustion air pipe and flow to the burner enclosure. Failure to follow this warning could result in product damage or improper operation, personal injury, or death.

- Install the Y concentric fitting pipe assembly up through the structure's hole and field supplied roof boot/flashing.

NOTICE

Do not allow insulation or other materials to accumulate inside the pipe assembly when installing through the hole.

- Secure the assembly to the roof structure as shown below in FIG. 5-7 using field supplied metal strapping or equivalent support material.

Figure 5-7 Concentric Vent Roof Installation

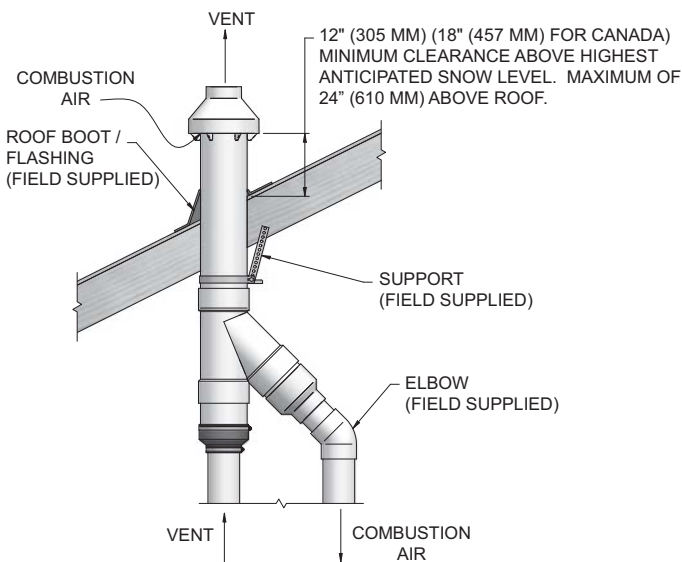

NOTICE

Ensure termination height is above the roof surface or anticipated snow level (12 inches (305 mm) in U.S.A. or 18 inches (457 mm) in Canada) as shown in FIG. 5-5, page 30.

NOTICE

If assembly is too short to meet height requirement, the two (2) pipes supplied in the kit may be replaced by using the same diameter, field supplied standard schedule 40 PVC for CVK3007. Do not extend dimension D* more than 60 inches (1524 mm) (see FIG. 4-9, page 25).

CAUTION

DO NOT use field-supplied couplings to extend pipes. Airflow restriction will occur.

- Install the rain cap and the small diameter pipe assembly into the roof penetration assembly. Ensure the small diameter pipe is fastened tightly into the rubber adapter for #CVK3007 installations.
- Cement the appliance combustion air and vent pipes to the concentric vent termination assembly. See FIG. 5-7 for proper pipe attachment.
- Operate the appliance through one (1) heat cycle to ensure combustion air and vent pipes are properly connected to the concentric vent termination connections.

Multiventing vertical terminations

When two (2) or more direct vent appliances are vented near each other, each appliance must be individually vented (see FIG. 5-8). NEVER common vent or breach vent this appliance. When two (2) or more direct vent appliances are vented near each other, two (2) vent terminations may be installed as shown in FIG. 5-8. The next two (2) terminations must be at least 36 inches (914 mm) away from the first two (2) terminations. It is important that vent terminations be made as shown to avoid recirculation of flue gases. Dimension A in FIG. 5-8 represents the distance between pipes or rain shields, as touching or a 2 inch (51 mm) maximum separation.

Figure 5-8 Concentric Vent and Combustion Air Vertical Termination (Dimension A as Touching or 2 inches (51 mm) Maximum Separation)

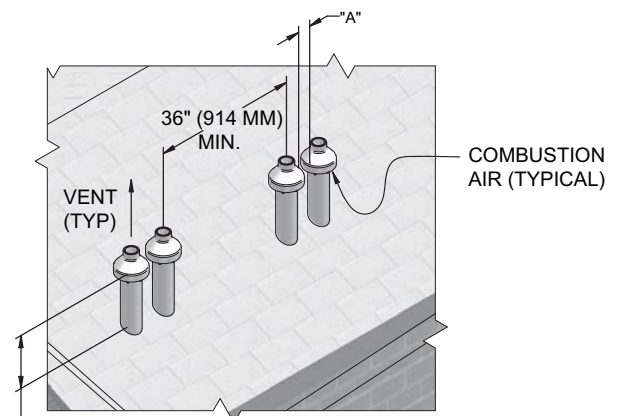

12" (305 MM) (18" (457 MM) FOR CANADA) MINIMUM CLEARANCE ABOVE HIGHEST ANTICIPATED SNOW LEVEL. MAXIMUM OF 24" (610 MM) ABOVE ROOF.

DIMENSION "A" IS TOUCHING OR 2" (51 MM) MAXIMUM SEPARATION

6 Hydronic piping

System water piping methods

The Knight XL is designed to function in a closed loop pressurized system not less than 12 psi (83 kPa). A temperature and pressure gauge is included to monitor system pressure and outlet temperature and should be located on the boiler outlet.

It is important to note that the boiler has a minimal amount of pressure drop which must be figured in when sizing the circulators. Each boiler installation must have an air elimination device, which will remove air from the system. Install the boiler so the gas ignition system components are protected from water (dripping, spraying, etc.) during appliance operation or basic service of circulator replacement, valves, and others.

Observe a minimum of 1 inch (25 mm) clearance around all un-insulated hot water pipes when openings around the pipes are not protected by non-combustible materials.

Low water cutoff device

On a boiler installed above radiation level, some states and local codes require a low water cutoff device at the time of installation.

Chilled water system

If the boiler supplies hot water to heating coils in air handler units, flow control valves or other devices must be installed to prevent gravity circulation of heater water in the coils during the cooling cycle. A chilled water medium must be piped in parallel with the heater.

Freeze protection

Freeze protection for new or existing systems must use glycol that is specially formulated for this purpose. This includes inhibitors, which prevent the glycol from attacking the metallic system components. Make certain to check that the system fluid is correct for the glycol concentration and inhibitor level. The system should be tested at least once a year and as recommended by the producer of the glycol solution. Allowance should be made for the expansion of the glycol solution in the system piping.

⚠ WARNING

Use only inhibited propylene glycol solutions, which are specifically formulated for hydronic systems. Ethylene glycol is toxic and can attack gaskets and seals used in hydronic systems.

General piping information

Basic steps are listed below along with illustrations on the following pages (FIG.'s 6-7 and 6-8), which will guide you through the installation of the Knight XL (reference FIG. 6-4).

1. Connect the system return marked "Inlet", make sure to install with pipe sealant compound.
2. Connect the system supply marked "Outlet", make sure to install with pipe sealant compound.
3. Install purge and balance valve or shutoff valve and drain on system return to purge air out of each zone.
4. Install a backflow preventer on the cold feed make-up water line.
5. Install a pressure reducing valve on the cold feed make-up water line, (15 psi (103 kPa) nominal). Check temperature and pressure gauge (shipped separately), which should read a minimum pressure of 12 psi (83 kPa).
6. Install a circulator as shown on the piping diagrams in this section. Make sure the circulator is properly sized for the system and friction loss.
7. Install an expansion tank on the system supply. Consult the tank manufacturer's instruction for specific information relating to tank installation. Size the expansion tank for the required system volume and capacity.
8. Install an air elimination device on the system supply.
9. Install a drain valve at the lowest point of the system. **Note:** The boiler cannot be drained completely of water without purging the unit with an air pressure of 15 psi (103 kPa).
10. This appliance is supplied with a relief valve sized in accordance with ASME Boiler and Pressure Vessel Code, Section IV ("Heating Boilers"). Pipe the discharge of the safety relief valve to prevent injury in the event of pressure relief. Pipe the discharge to a drain. Provide piping that is the same size as the safety relief valve outlet. Never block the outlet of the safety relief valve.

⚠ WARNING

The relief valve, tee and any other necessary fittings are shipped in the install kit with the boiler and are to be field installed (FIG.'s 6-1 and 6-2).

11. On any pre-existing system, it is good practice to install a field supplied strainer to prevent damage to the heat exchanger.

See the piping illustrations included in this section, FIG.'s 6-4 and 6-5 for suggested guidelines in piping the Knight XL.

NOTICE

Please note that these illustrations are meant to show system piping concept only, the installer is responsible for all equipment and detailing required by local codes.

6 Hydronic piping

Flow switch, relief valve and temperature and pressure gauge installation

Basic steps are listed below to guide you through the installation of the flow switch, relief valve, and temperature and pressure gauge provided with the unit.

1. For Models 399 - 500 install the close nipple on the outlet connection of the heat exchanger. Install the tee with the 3/4 inch fitting positioned vertically and on the top as shown in FIG. 6-1. For Models 600 - 800 install the tee directly to the outlet connection of the heat exchanger with the 3/4 inch fitting positioned vertically and on the top (see FIG. 6-2).
2. For Models 700 - 800 install the 3/4 inch close nipple in the tee. Install the relief valve on the 3/4 inch close nipple (FIG. 6-2). For Models 399 - 600 install the relief valve directly into the 3/4 inch fitting on the tee (FIG. 6-1).
3. Install the close nipple on the downstream side of the relief valve tee (FIG. 6-1).
4. Install the tee with the 1 inch fitting positioned vertically and on the top (FIG. 6-1).
5. Attach paddle #3 to the flow switch per the manufacturer's instructions.
6. Install the assembled flow switch into the 1 inch fitting of the tee installed in Step 4 (see FIG. 6-1).
7. Install a field provided close nipple on the downstream side of the flow switch (see FIG.'s 6-1 and 6-2).
8. Install a field provided tee with the gauge fitting positioned vertically and on the top (FIG.'s 6-1 and 6-2)
9. Install the temperature and pressure gauge provided with the unit into the top fitting of the tee (a bushing may be necessary) installed in Step 8 (FIG.'s 6-1 and 6-2).

NOTICE

Be sure to install the flow switch so that the arrow on the flow switch is pointing in the direction of the flow (see FIG. 6-3).

Figure 6-1 Flow Switch, Relief Valve and Temperature and Pressure Gauge Installation_Models 399 - 500

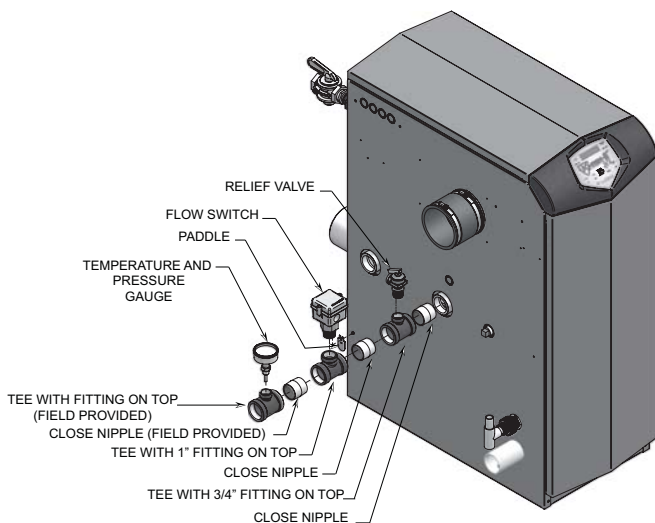
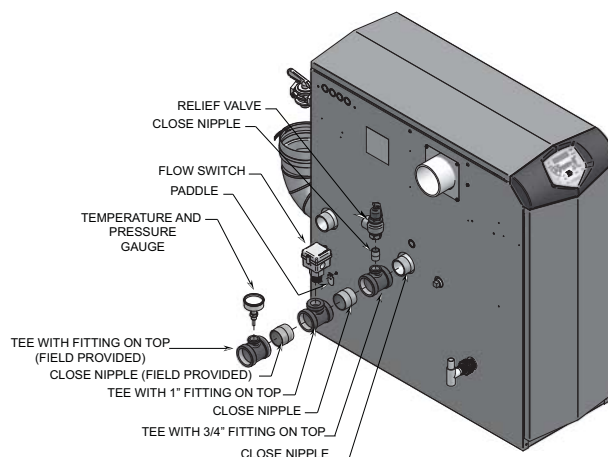

Figure 6-2 Flow Switch, Relief Valve and Temperature and Pressure Gauge Installation_Models 600 - 800



6 Hydronic piping

Flow switch adjustment

Refer to Table 6A for the proper setting of the sensitivity screw. For reference, the position of the screw prior to setting should be turned clockwise with a Phillips driver until it stops (FIG. 6-3). Proceed to turn the screw counterclockwise the amount of turns listed in Table 6A based on the model.

Consult the manufacturer's instructions for wiring the flow switch to your system.

Table 6A Paddle Size / Sensitivity Screw Adjustment

MODEL	PADDLE SIZE	SENSITIVITY SCREW ADJUSTMENT
Note: Paddles are included with the flow switch.		
399	#3	7½ turns
500	#3	5½ turns
600	#3	7¼ turns
700	#3	5¼ turns
800	#3	3¼ turns

NOTICE

Turn the sensitivity screw clockwise to increase the flow rate required to activate the switch. Turn the sensitivity screw counterclockwise to decrease the flow rate required to activate the switch.

Figure 6-3 Flow Switch Adjustment

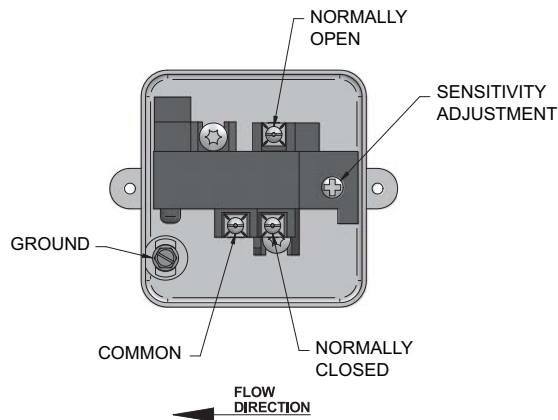

Circulator sizing

The Knight XL heat exchanger does have a pressure drop, which must be considered in your system design. Refer to the graphs in FIG's 6-5 and 6-6 for pressure drop through the Knight XL heat exchanger.

Near boiler piping connections

Figure 6-4 Near Boiler Piping

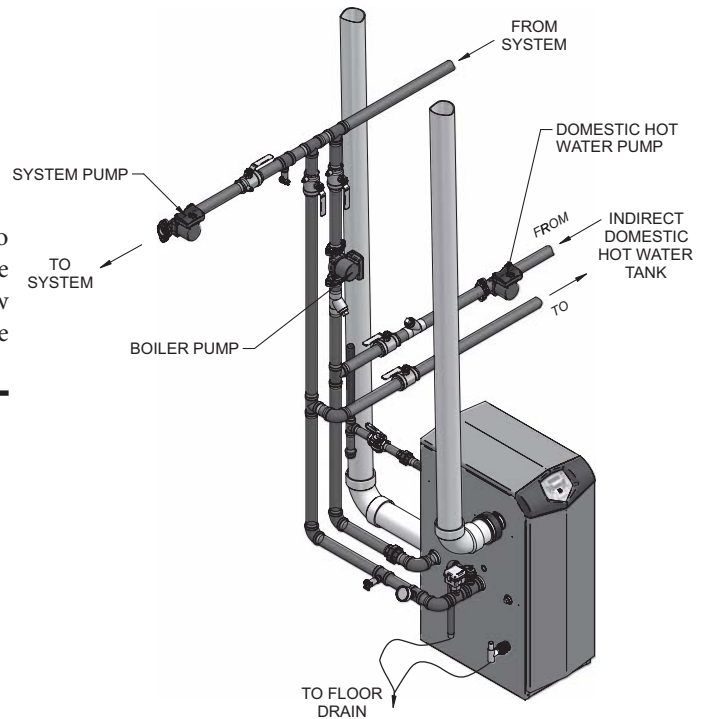

6 Hydronic piping

Figure 6-5 Pressure Drop vs. Flow - Models 399 and 500

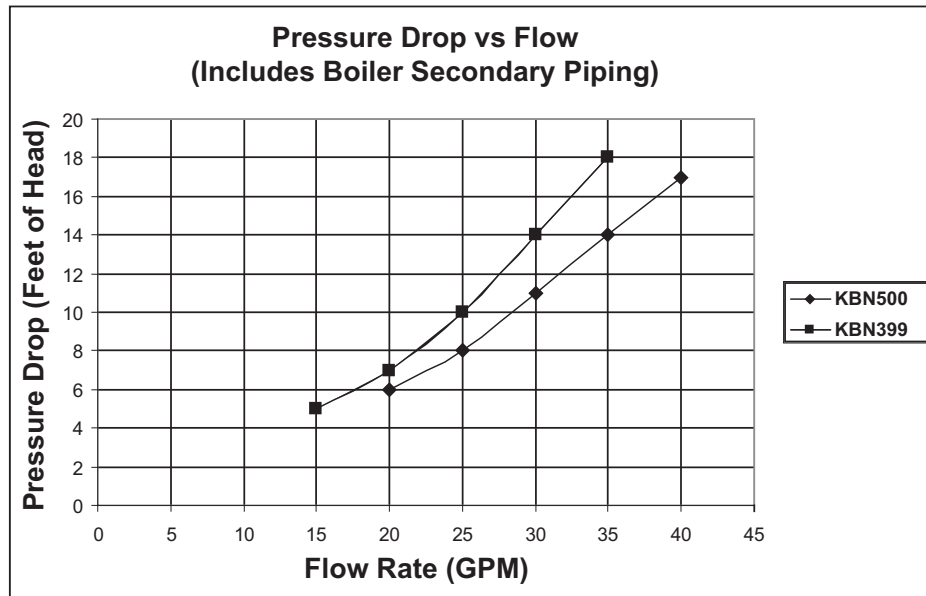

Figure 6-6 Pressure Drop vs. Flow - Models 600 thru 800

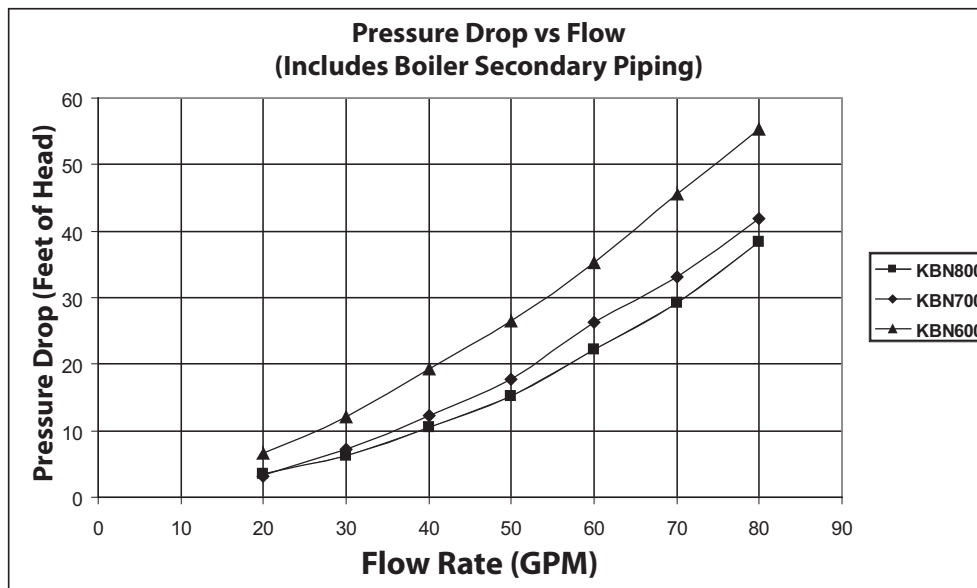

Table 6B Sizing Information for Temperature Rise Applications_20°F, 25°F, 30°F and 35°F

TEMPERATURE RISE APPLICATIONS									
Model	MINIMUM PIPE SIZE	20°F		25°F		30°F		35°F	
		GPM	FT/HD	GPM	FT/HD	GPM	FT/HD	GPM	FT/HD
399	1 1/2"	37	21	30	14	26	11	21	8
500	1 1/2"	46	23	37	16	32	13	26	10
600	2"	55	31	44	22	38	18	32	13
700	2"	65	30	52	20	45	16	37	11
800	2"	74	33	60	23	51	18	42	12

6 Hydronic piping

NOTICE

Pump sizing and flow requirements are based on 20 feet (6 m) of piping, 4 - 90° elbows, and 2 - fully ported ball valves.

NOTICE

It is required that near boiler piping systems utilize *Primary/Secondary* configurations as shown in FIG.'s 6-7 and 6-8 only. The use of other near boiler piping configurations could result in improper building and system flow rates leading to inadvertent boiler high limit shutdowns and poor system performance.

Near boiler piping components

- 1. Boiler system piping:**

Boiler system piping **MUST** be sized per the pipe requirements listed in Table 6B. Reducing the pipe size can restrict the flow rate through the boiler, causing inadvertent high limit shutdowns and poor system performance. Flow rates are based on 20 feet (6 m) of piping, 4 - 90° elbows, and 2 - fully ported ball valves.
- 2. Boiler system circulating pump:**

Field supplied. The boiler circulating pump should be based on 20 feet (6 m) of piping, 4 - 90° elbows, and 2 - fully ported ball valves.
- 3. Domestic hot water circulating pump:**

Field supplied. The pump **MUST** be sized to meet the specified minimum flow requirements listed in FIG.'s 6-5 and 6-6. Consult the indirect water heater operating guide to determine flow characteristics for the selected product used.
- 4. Boiler isolation valves:**

Field supplied. Full port ball valves are required. Failure to use full port ball valves could result in a restricted flow rate through the boiler.
- 5. Check valves:**

Field supplied. Check valves are recommended for installation as shown in FIG.'s 6-7 and 6-8. Failure to install check valves could result in a reverse flow condition during pump(s) off cycle.
- 6. Domestic indirect hot water isolation valves:**

Field supplied. Full port ball valves are required. Failure to use full port ball valves could result in a restricted flow rate through the boiler.
- 7. Anti-scald mixing valve:**

Field supplied. An anti-scald mixing valve is recommended when storing domestic hot water above 115°F (46°C).
- 8. Unions:**

Field supplied. Recommended for unit serviceability.
- 9. Temperature and pressure gauge:**

Factory supplied. The temperature and pressure gauge is shipped loose. It is the responsibility of the contractor to install the temperature and pressure gauge on the boiler water outlet.
- 10. Pressure relief valve:**

Factory supplied. The pressure relief valve is sized to ASME specifications.
- 11. Boiler purge valve:**

Field supplied. The boiler purge valve is used to remove entrapped air from the heat exchanger during start-up.
- 12. System temperature sensor:**

Lochinvar supplies a system temperature sensor. The sensor is to be installed in the heating loop downstream from the boiler hot water piping and heating loop junction. The sensor should be located far enough downstream to sense system diluted water temperature.

6 Hydronic piping *(continued)*

Figure 6-7 Single Boiler - Primary/Secondary Piping

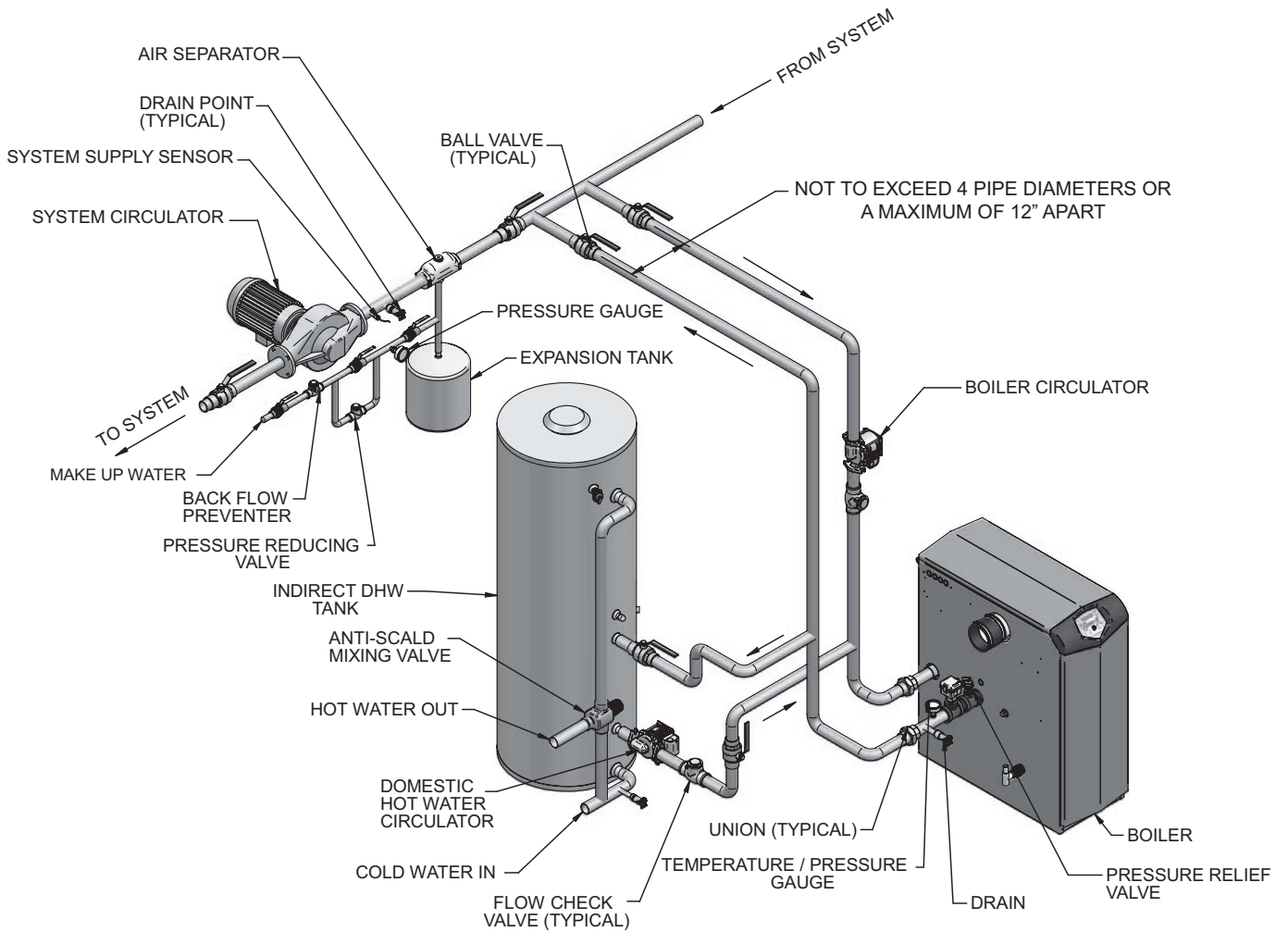

NOTICE

System flow should always remain higher than the required flow for the boiler(s) when the boiler(s) is in operation to prevent short cycling and high limit issues.

6 Hydronic piping

Figure 6-8 Multiple Boilers - Primary/Secondary Piping

Model	Number of Units						
	2	3	4	5	6	7	8
	Manifold Pipe Sizes in Inches (mm)						
399	2 1/2 (64)	3 (76)	3 1/2 (89)	4 (102)	4 (102)	5 (127)	6 (152)
500	3 (76)	3 1/2 (89)	4 (102)	5 (127)	5 (127)	6 (152)	6 (152)
600	3 1/2 (89)	4 (102)	5 (127)	5 (127)	6 (152)	6 (152)	8 (203)
700	3 1/2 (89)	5 (127)	5 (127)	6 (152)	6 (152)	8 (203)	8 (203)
800	4 (102)	5 (127)	5 (127)	6 (152)	8 (203)	8 (203)	8 (203)

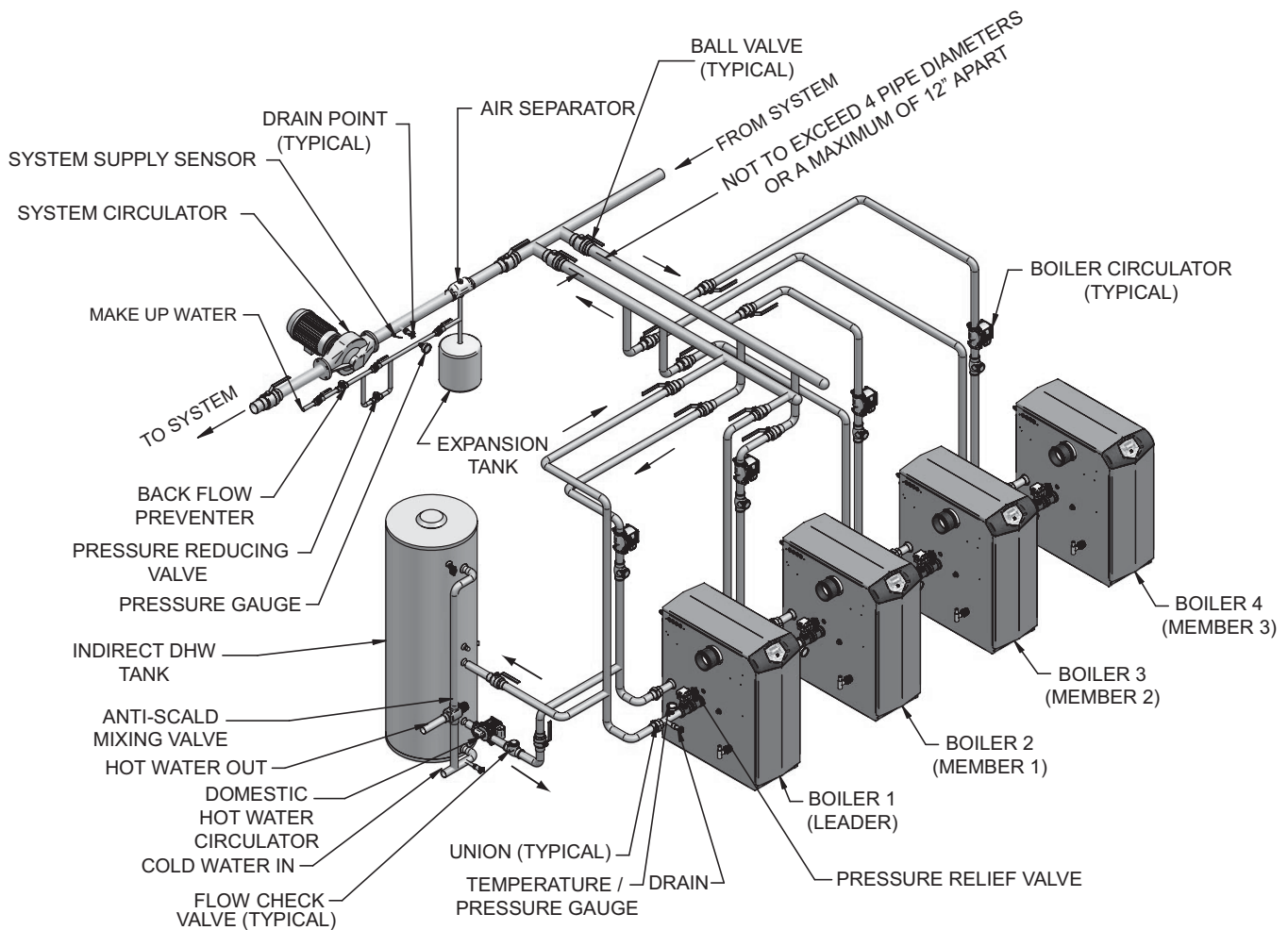

NOTICE

System flow should always remain higher than the required flow for the boiler(s) when the boiler(s) is in operation to prevent short cycling and high limit issues.

7 Gas connections

Connecting gas supply piping

1. Remove the top access panel and refer to FIG.'s 7-1 thru 7-3 to pipe gas to the boiler.
 - a. Install ground joint union for servicing, when required.
 - b. Install a manual shutoff valve in the gas supply piping outside boiler jacket when required by local codes or utility requirements.
 - c. In Canada – When using manual main shutoff valves, it must be identified by the installer.
2. Install sediment trap / drip leg.

Figure 7-1 Gas Supply Piping - Model 399

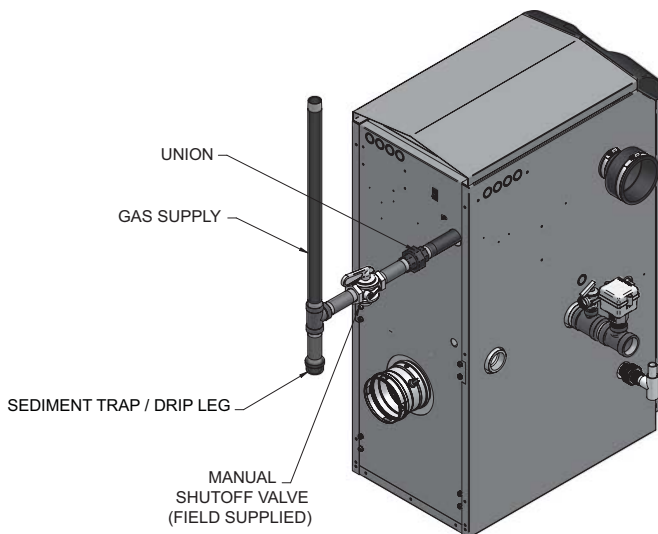

Figure 7-2 Gas Supply Piping - Model 500

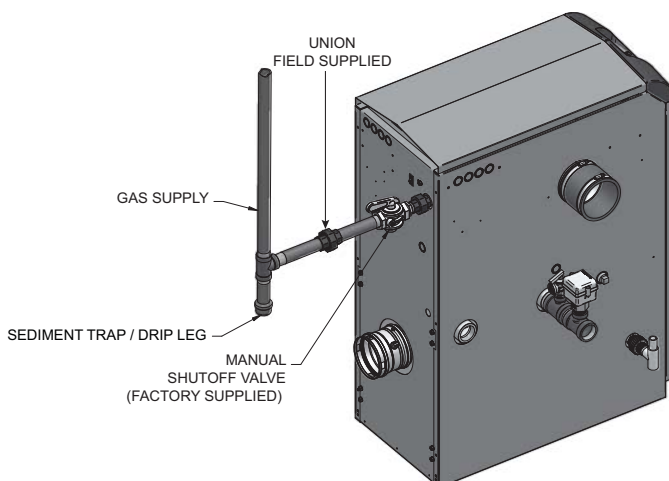
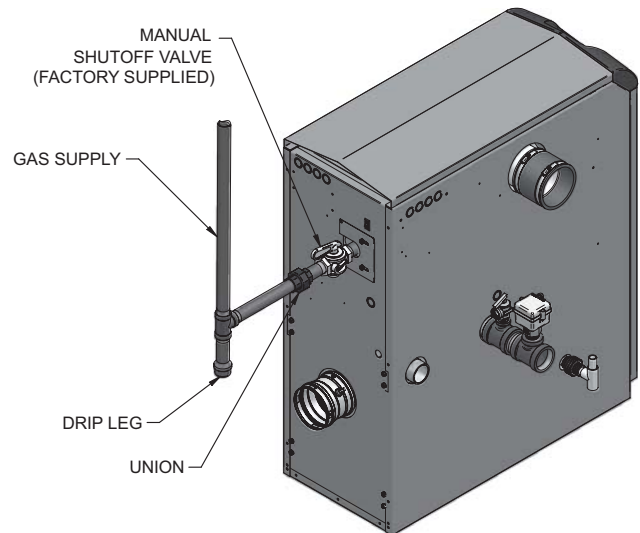

Figure 7-3 Gas Supply Piping - Models 600 - 800



3. Support piping with hangers, not by the boiler or its accessories.

⚠ WARNING

The gas valve and blower will not support the weight of the piping. Do not attempt to support the weight of the piping with the boiler or its accessories. Failure to comply could result in severe personal injury, death, or substantial property damage.

4. Purge all air from the gas supply piping.
5. Before placing the boiler in operation, check the boiler and its gas connection for leaks.
 - a. The appliance must be disconnected from the gas supply piping system during any pressure testing of that system at a test pressure in excess of 1/2 PSIG (3.5 kPa).
 - b. The appliance must be isolated from the gas supply piping system by closing a manual shutoff valve during any pressure testing of the gas supply piping system at test pressures equal to or less than 1/2 PSIG (3.5 kPa).
 - c. The appliance and its gas connection must be leak tested before placing it in operation.

⚠ WARNING

Do not check for gas leaks with an open flame – use the bubble test. Failure to use the bubble test or check for gas leaks can cause severe personal injury, death, or substantial property damage.

6. Use pipe sealing compound compatible with propane gases. Apply sparingly only to male threads of the pipe joints so that pipe dope does not block gas flow.

7 Gas connections

⚠ WARNING Failure to apply pipe sealing compound as detailed in this manual can result in severe personal injury, death, or substantial property damage.

⚠ WARNING Use two wrenches when tightening gas piping at boiler (FIG. 7-4), using one wrench to prevent the boiler gas line connection from turning. Failure to support the boiler gas connection pipe to prevent it from turning could damage gas line components.

Figure 7-4 Inlet Pipe with Backup Wrench

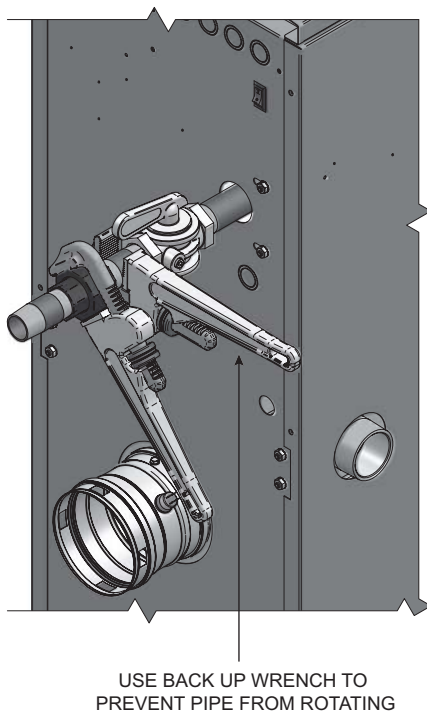

NOTICE Maximum inlet gas pressure must not exceed the value specified. Minimum value listed is for the purposes of input adjustment.

Natural gas:

Pipe sizing for natural gas

- Refer to Table 7A for pipe length and diameter. Based on rated boiler input (divide by 1,000 to obtain cubic feet per hour).
 - Table 7A is only for natural gas with specific gravity 0.60 inches, with a pressure drop through the gas piping of 0.5 inches w.c.
 - For additional gas pipe sizing information, refer to ANSI Z223.1 (or B149.1 for Canadian installations).

Natural gas supply pressure requirements

- Pressure required at the gas valve inlet pressure port:
 - Maximum 14 inches w.c. (3.5 kPa) with no flow (lockup) or with boiler on.
 - Minimum 4 inches w.c. (.99 kPa) with gas flowing (verify during boiler startup).
- Install 100% lockup gas pressure regulator in supply line if inlet pressure can exceed 14 inches w.c. (3.5 kPa) at any time. Adjust lockup regulator for 14 inches w.c. (3.5 kPa) maximum.

Propane Gas:

⚠ WARNING Knight XL boilers are typically shipped ready to fire on natural gas. Check boiler rating plate to determine which fuel the boiler is set for. If set to natural gas, it may be converted to LP by installing an orifice or by making a gas valve adjustment (see pages 12 and 13). In order to operate on LP gas, an orifice **MUST BE** installed or a gas valve adjustment **MUST BE** made. Failure to comply could result in severe personal injury, death, or substantial property damage.

Pipe sizing for propane gas

- Contact gas supplier to size pipes, tanks, and 100% lockup gas pressure regulator.

Propane Supply Pressure Requirements

- Adjust propane supply regulator provided by the gas supplier for 14 inches w.c. (3.2 kPa) maximum pressure.
- Pressure required at gas valve inlet pressure port:
 - Maximum 14 inches w.c. (3.2 kPa) with no flow (lockup) or with boiler on.
 - Minimum 8 inches w.c. (1.9 kPa) with gas flowing (verify during boiler startup).

⚠ WARNING Ensure that the high gas pressure regulator is at least 10 feet (3 m) upstream of the appliance.

7 Gas connections *(continued)*

Table 7A Natural Gas Pipe Size Chart

Nominal Iron Pipe Size (inches)	Natural Gas Pipe Capacity Chart Length of Pipe in Straight Feet														Maximum Capacity of Pipe in Thousands of Btu/hr per hour for gas pressures of 14 Inches Water Column (0.5 PSIG) or less and a pressure drop of 0.5 Inch Water Column (Based on NAT GAS, 1025 Btu/hr per Cubic Foot of Gas and 0.60 Specific Gravity)
	10	20	30	40	50	60	70	80	90	100	125	150	175	200	
1/2	175	120	97	82	N/A	N/A	N/A	N/A	N/A	N/A	N/A	N/A	N/A	N/A	
3/4	369	256	205	174	155	141	128	121	113	106	95	86	79	74	
1	697	477	384	328	292	267	246	236	210	200	179	164	149	138	
1-1/4	1400	974	789	677	595	543	502	472	441	410	369	333	308	287	
1-1/2	2150	1500	1210	1020	923	830	769	707	666	636	564	513	472	441	
2	4100	2820	2260	1950	1720	1560	1440	1330	1250	1180	1100	974	871	820	
2-1/2	6460	4460	3610	3100	2720	2460	2310	2100	2000	1900	1700	1540	1400	1300	
3	11200	7900	6400	5400	4870	4410	4000	3800	3540	3330	3000	2720	2500	2340	
4	23500	16100	13100	11100	10000	9000	8300	7690	7380	6870	6150	5640	5130	4720	

Check inlet gas supply

NOTICE

CSA or UL listed flexible gas connections are acceptable, but you must exercise caution to ensure that the line has adequate capacity to allow your boiler to fire at full rate. Consult with local codes for proper installation or service procedures.

⚠ WARNING

DO NOT adjust or attempt to measure gas valve outlet pressure. Attempting to alter or measure the gas valve outlet pressure could result in damage to the valve, causing potential severe personal injury, death, or substantial property damage.

The gas piping must be sized for the proper flow and length of pipe, to avoid excessive pressure drop. Both the gas meter and the gas regulator must be properly sized for the total gas load.

If you experience a pressure drop greater than 1 inch w.c. (249 Pa), the meter, regulator, or gas line is undersized or in need of service. Perform the steps below when checking inlet gas supply:

- Turn the main power switch to the “OFF” position.
- Shut off gas supply at the manual gas valve in the gas piping to the appliance.
- On Models 399 - 500 loosen the set screw one (1) full turn from inside the pressure tap on top of the gas valve. On Models 600 - 800 remove the 1/8" (3 mm) pipe plug on the inlet flange to the valve and install a suitable 1/8" (3 mm) fitting (field supplied) for the manometer tubing. Place the tubing of the manometer over the tap once the set screw is loosened or the 1/8" (3 mm) fitting is installed (depending on model) as shown in FIG.'s 7-5 thru 7-7 on page 42.
- Slowly turn on the gas supply at the field installed manual gas valve.
- Turn the power switch to the “ON” position.
- Adjust the temperature set point on the control panel of the SMART SYSTEM control module to call for heat.
- Observe the gas supply pressure as the burner fires at 100% of rated input. Percent of burner input will be displayed on the control panel.
- Ensure inlet pressure is within specified range. Minimum and maximum gas supply pressures are specified in this section of the manual.
- If gas supply pressure is within normal range and no adjustments are needed, proceed on to Step 11.
- If the gas pressure is out of range, contact the gas utility, gas supplier, qualified installer or service agency to determine the necessary steps to provide proper gas pressure to the control.
- Turn the power switch to the “OFF” position.
- Shut off the gas supply at the manual gas valve in the gas piping to the appliance.
- Remove the manometer from the pressure tap on top of the gas valve. On Models 399 - 500 re-tighten the set screw inside the pressure tap. On Models 600 - 800 remove the 1/8" (3 mm) field supplied fitting and reinstall the pipe plug removed in Step 3.

7 Gas connections

⚠ WARNING When re-tightening the set screw, be sure to tighten securely to prevent gas leaks.

Do not check for gas leaks with an open flame -- use the bubble test. Failure to use the bubble test or check for gas leaks can cause severe personal injury, death, or substantial property damage.

14. Turn on the gas supply at the manual gas valve.
15. Turn the power switch to the "ON" position.
16. Adjust the temperature set point on the control panel of the SMART SYSTEM control module to the desired water temperature so the appliance will call for heat.
17. Check burner performance by cycling the system while you observe burner response. The burner should ignite promptly. Flame pattern should be stable. Turn system off and allow burner to cool, then cycle burner again to ensure proper ignition and flame characteristics.

Figure 7-5 Inlet Gas Supply Check - Model 399

LOOSEN THE SET SCREW ONE (1) FULL TURN AND PLACE THE MANOMETER TUBING OVER THE PRESSURE TAP.

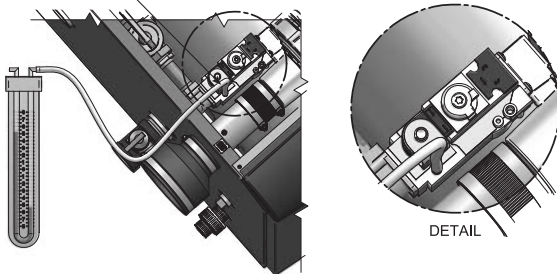

Figure 7-6 Inlet Gas Supply Check - Model 500

LOOSEN THE SET SCREW ONE (1) FULL TURN AND PLACE THE MANOMETER TUBING OVER THE PRESSURE TAP.

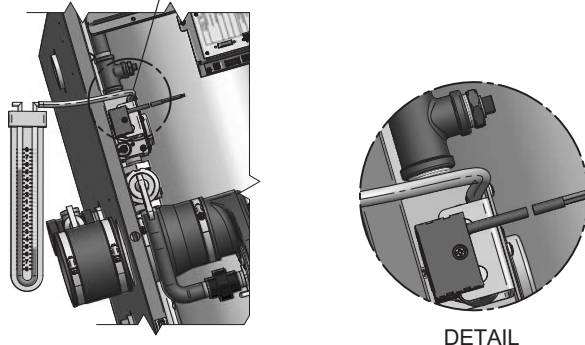
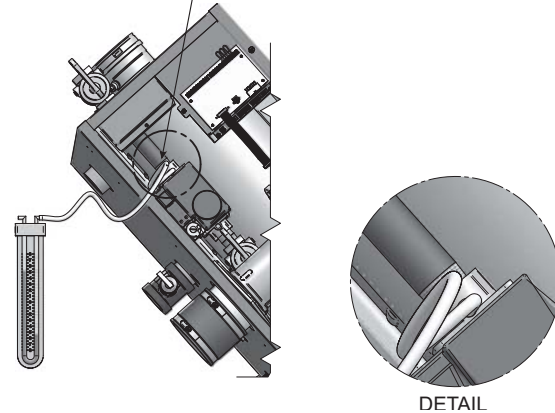

Figure 7-7 Inlet Gas Supply Check - Models 600 - 800

REMOVE THE 1/8" (3 MM) PIPE PLUG ON THE INLET FLANGE TO THE VALVE AND INSTALL A SUITABLE 1/8" (3 MM) FITTING (FIELD SUPPLIED) FOR THE MANOMETER TUBING.



Gas Pressure

The gas pressure must remain between 4 inches w.c. (.99 kPa) minimum and 14 inches w.c. (3.5 kPa) maximum for Natural gas and between 8 inches w.c. (1.9 kPa) minimum and 14 inches w.c. (3.2 kPa) maximum for LP gas during standby (static) mode and while in operating (dynamic) mode. If an in-line regulator is used, it must be a minimum of 10 feet (3 m) from the Knight XL boiler. It is very important that the gas line is properly purged by the gas supplier or utility company. Failure to properly purge the lines or improper line sizing, will result in ignition failure.

The problem is especially noticeable in NEW LP installations and also in empty tank situations. This can also occur when a utility company shuts off service to an area to provide maintenance to their lines.

Gas valve replacement

The gas valve **MUST NOT** be replaced with a conventional gas valve under any circumstances. As an additional safety feature, this gas valve has a flanged connection to the venturi and blower.

⚠ WARNING Failure to follow all precautions could result in fire, explosion, or death!

⚠ WARNING DO NOT adjust or attempt to measure gas valve outlet pressure. Attempting to alter or measure the gas valve outlet pressure could result in damage to the valve, causing potential severe personal injury, death, or substantial property damage.

8 Field wiring

⚠ WARNING ELECTRICAL SHOCK HAZARD – For your safety, turn off electrical power supply before making any electrical connections to avoid possible electric shock hazard. Failure to do so can cause severe personal injury or death.

NOTICE Wiring must be N.E.C. Class 1.

If original wiring as supplied with boiler must be replaced, use only type 105°C wire or equivalent.

Boiler must be electrically grounded as required by National Electrical Code ANSI/NFPA 70 – latest edition.

⚠ CAUTION Label all wires prior to disconnection when servicing controls. Wiring errors can cause improper and dangerous operation.

Installation must comply with:

1. National Electrical Code and any other national, state, provincial, or local codes, or regulations.
2. In Canada, CSA C22.1 Canadian Electrical Code Part 1, and any local codes.

Line voltage connections

1. Connect 120 VAC power wiring to the line voltage terminal strip in the junction box, as shown in FIG. 8-1.
2. Provide and install a fused disconnect or service switch (15 amp recommended) as required by the code (see FIG. 8-1).
3. When connecting a domestic hot water (DHW) pump, connect the wiring to the line voltage terminal strip as shown in FIG. 8-1.
4. To activate a system pump, wire as shown in FIG. 8-1. Dry contacts are sized for 1.5 hp/120V, 3 hp/240V or 30 amps.

Figure 8-1 Line Voltage Field Wiring Connections

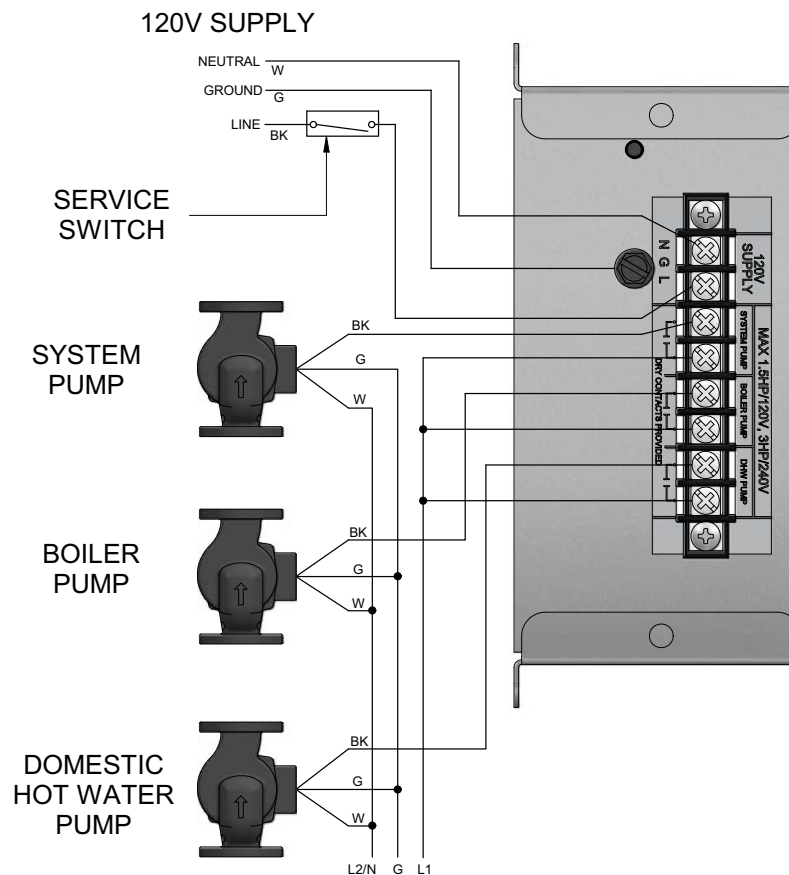

8 Field wiring

Low voltage connections

1. Route all low voltage wires through the knockouts in the rear of the boiler, as shown in FIG. 8-2.
2. Connect low voltage wiring to the low voltage connection board as shown in FIG. 8-3 on page 46 of this manual and the boiler wiring diagram.

Figure 8-2 Routing Field Wiring

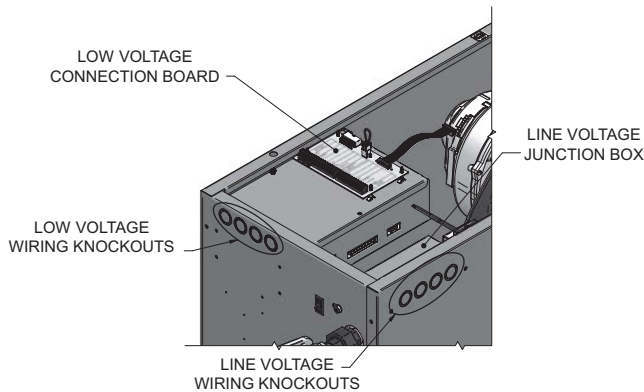

Thermostat

1. Connect the room thermostat or end switch (isolated contact only) to terminals R and W, as shown in FIG. 8-3.
2. Install the thermostat on the inside wall away from influences of drafts, hot or cold water pipes, lighting fixtures, television, sunlight, or fireplaces.
3. Thermostat anticipator (if applicable):
 - a. If connected directly to boiler, set for 0.1 amps.
 - b. If connected to relays or other devices, set to match total electrical power requirements of connected devices. See device manufacturers' specifications and thermostat instructions for details.

Outdoor temperature sensor

1. Connect the outdoor temperature sensor (FIG. 8-3) to the Outdoor Sensor terminals on the connection board to enable outdoor reset operation of the Knight XL. Do not install the outdoor sensor.
2. Mount the sensor on an exterior wall, shielded from direct sunlight or flow of heat or cooling from other sources.
3. Route sensor wires through a knockout at the rear of the boiler (see FIG. 8-2).

DHW (Domestic Hot Water) thermostat

1. Connect the DHW tank thermostat to the Tank Thermostat terminals on the connection board (FIG. 8-3).

DHW tank sensor

By installing a tank sensor, the SMART SYSTEM control can perform the tank thermostat function. The SMART SYSTEM control automatically detects the presence of this sensor, and generates a DHW call for heat when the tank temperature drops 6°F (3°C) below the tank set point, and finishes the call for heat when the tank temperature reaches the tank set point.

The tank sensor included with the Lochinvar Squire® indirect DHW tanks (TST2032) is the only sensor suitable for use with the SMART SYSTEM control. Connect the sensor leads to the DHW Tank Sensor (AUX) terminals on the low voltage connection board (FIG. 8-3). Consult the tank manufacturer for application and performance when used with any other indirect tank.

⚠ WARNING

Failure to use the correct sensor may result in the tank temperature being either above or below the set point. Failure to consult the manufacturer of the indirect tank, when the Squire is not used, may result in decreased performance or the risk of scald injury.

If TST2032 is not compatible with the indirect tank, a tank thermostat can be used to control the boiler. The tank thermostat should be installed per the manufacturer's instructions and wired to the DHW Thermostat terminals on the low voltage connection board (FIG. 8-3).

Auxiliary device proving switch

1. When the operation of an auxiliary device needs to be verified before the boiler fires, remove the jumper wire from these terminals and connect them to the normally open contacts on its proving switch (FIG. 8-3).

High gas pressure switch

1. If a switch is provided to detect excessive gas pressure, remove the jumper wire from the terminals on the connection board, and then connect them to its normally closed contacts (FIG. 8-3).

Low gas pressure switch

1. If a switch is provided to detect low gas pressure, remove the jumper wire from the terminals on the connection board and connect them to its normally open contacts (FIG. 8-3).
2. If both a high and low gas pressure switch is used, connect their respective contacts in series, and connect them to the terminals on the connection board (FIG. 8-3).

Flow switch

1. A flow switch is used to guarantee flow through the boiler before allowing it to fire. The flow switch must be installed in line with the boiler.
2. Remove the jumper wire from the terminals on the connection board and connect these terminals to the normally open contacts on the flow switch (FIG. 8-3).

8 Field wiring *(continued)*

System supply sensor

1. By installing the system supply sensor into the supply of the primary loop, the temperature of the system supply can be controlled. The SMART SYSTEM control automatically detects the presence of this sensor, and controls the boiler firing rate to maintain the system supply temperature to the set point (if the outlet sensor control is currently selected). See the Knight XL Service Manual for instructions on how to use the inlet sensor as the controlling sensor. When the inlet sensor is programmed as the controlling sensor, it is vital that the SYSTEM SUPPLY sensor be installed. **DO NOT INSTALL THE SYSTEM SUPPLY SENSOR INTO THE SYSTEM RETURN.**
2. Connect these terminals to the system supply sensor (FIG. 8-3).

Boiler management system

1. An external control may be connected to control either the firing rate or the set point of the boiler. Connect the Room Thermostat / Zone Control terminals to the enable output of the external control and connect the 0 - 10 VDC terminals to the 0 - 10 VDC output of the external control.
2. Make sure the ground terminal is connected to the ground output terminal of the external control, and the 0 - 10 VDC terminal is connected to the 0 - 10 VDC terminal of the external control.

Runtime contacts

The SMART SYSTEM control closes a set of dry contacts whenever the burner is running. This is typically used by Building Management Systems to verify that the boiler is responding to a call for heat.

Alarm contacts

The SMART SYSTEM control closes another set of contacts whenever the boiler is locked out or the power is turned off. This can be used to turn on an alarm, or signal a Building Management System that the boiler is down. Note that these contacts will close momentarily at the end of each call for heat or at least every 24 hours.

Wiring of the cascade

When wiring the boilers for Cascade operation, select one boiler as the Leader boiler. The remaining boilers will be designated as Members. See page 53 “Configuration of the Cascade” for a detailed explanation of this procedure.

Connect the system supply sensor and outdoor air sensor (if used) to the Leader boiler. For the Cascade system to work properly the system supply sensor must be installed. The location of the system supply sensor should be downstream of the boiler connections in the main system loop (FIG.s 6-7 and 6-8). The system supply sensor should be wired to the Low Voltage Connection Board at the terminals marked for the system supply sensor (see FIG. 8-3). The Leader control will use the water temperature at the system supply sensor to control the operation of the Cascade.

If outdoor air reset is desired, the outdoor air sensor should be wired to the Low Voltage Connection Board at the terminals marked for the outdoor air sensor (FIG. 8-3). If the outdoor air sensor is connected, the Leader control will calculate the water temperature set point based on the programmed reset curve parameters. If the outdoor air sensor is not connected, the Leader control will maintain the fixed water temperature set point that is programmed into the control.

If a Thermostat or Zone Control enable output is available, it should be wired to the Low Voltage Connection Board on the Leader boiler at the terminals marked for the Room Thermostat/Zone Control (FIG. 8-3). If the boilers are to run continuously, connect a jumper wire between the R and W terminals for the Thermostat/Zone Control input. This will initiate a call for heat on the Cascade.

Communication between the Leader boiler and the Member boilers is accomplished by using shielded, 2-wire twisted pair communication cable. Connect one of the twisted pair wires to terminal A on each of the Low Voltage Connection boards, and the other wire of the twisted pair to terminal B on each of the Low Voltage Connection Boards. Connect the shield wires to one of the shield ground terminals on the Low Voltage Connection Boards (FIG. 8-3). If more than two boilers are on the Cascade, daisy chain the wiring from the Sequencing terminals on the second boiler to the Sequencing terminals on the third boiler, then from the third to the fourth, and so on. The connections between boilers can be made in any order, regardless of the addresses of the boilers. Try to keep each cable as short as possible.

8 Field wiring

Figure 8-3 Low Voltage Field Wiring Connections

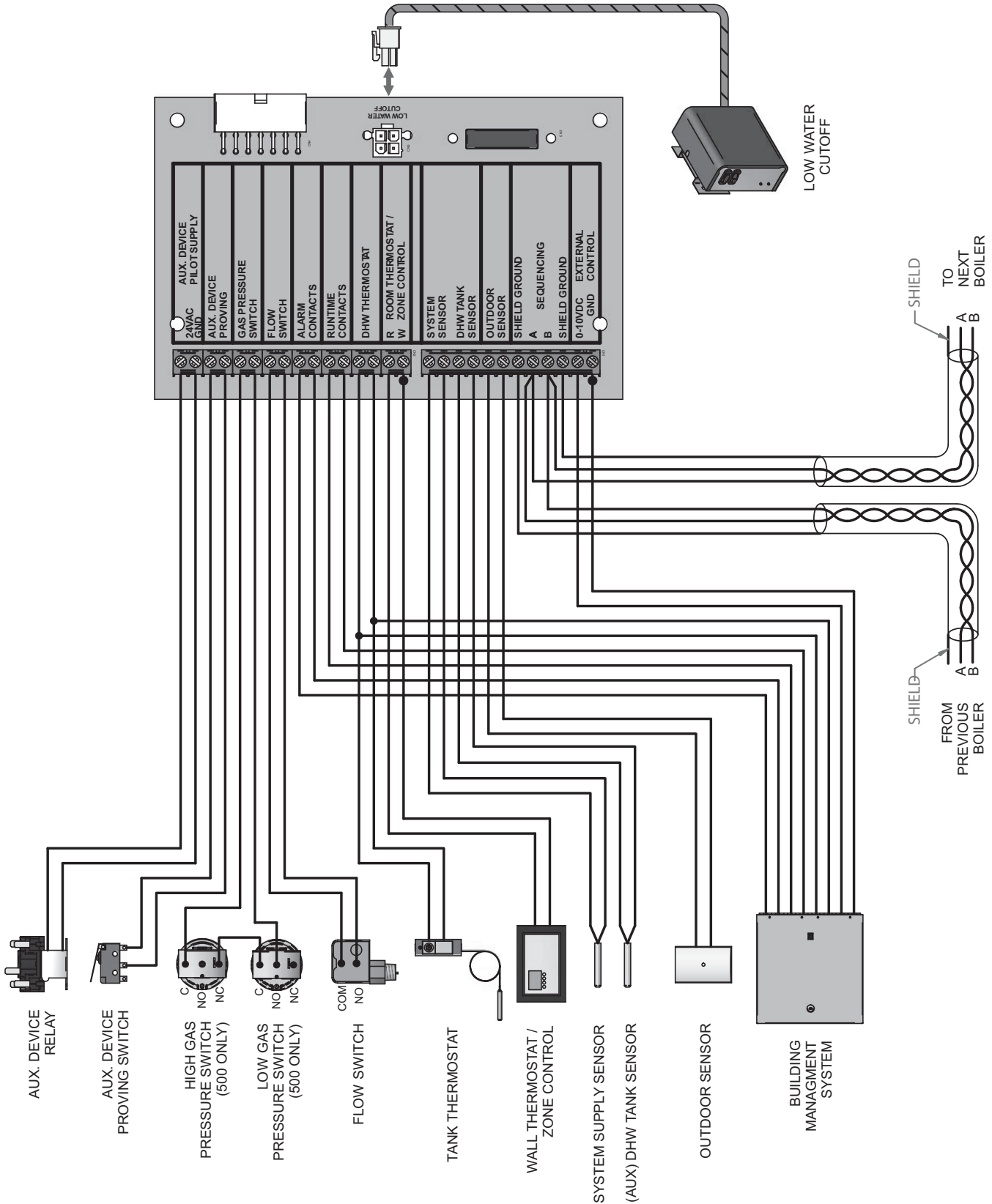

9 Condensate disposal

Condensate drain

1. This boiler is a high efficiency appliance that produces condensate.
2. The side of the boiler has a 1/2 inch (12.7 mm) PVC union for connection of a 1/2 inch (12.7 mm) PVC pipe (FIG. 9-1).
3. Slope condensate tubing down and away from the boiler into a drain or condensate neutralizing filter. Condensate from the Knight XL will be slightly acidic (typically with a pH from 3 to 5). Install a neutralizing filter if required by local codes.

A Neutralizer Kit (FIG. 9-1) is available from the factory (KIT3087 for Models 399 - 500 and KIT3046 for Models 600 - 800).

4. Install the 1/2 inch (12.7 mm) PVC tee assembly (shipped with the unit) as shown in FIG. 9-1.
5. Leave the top of the 1/2 inch (12.7 mm) tee OPEN. This is needed as a vacuum break.
6. Do not expose condensate line to freezing temperatures.
7. Use only plastic tubing or piping as a condensate drain line (FIG. 9-1).

NOTICE

Use materials approved by the authority having jurisdiction. In the absence of other authority, PVC and CPVC pipe must comply with ASTM D1785 or D2845. Cement and primer must comply with ASME D2564 or F493. For Canada use CSA or ULC certified PVC or CPVC pipe, fittings, and cement.

NOTICE

To allow for proper drainage on large horizontal runs, a second line vent may be required and tubing size may need to increase to 1 inch (25 mm).

The condensate line must remain unobstructed, allowing free flow of condensate. If condensate is allowed to freeze in the line or if the line is obstructed in any other manner, condensate can exit from the boiler tee, resulting in potential water damage to property.

8. A condensate removal pump is required if boiler is below drain. When installing a condensate pump, select one approved for use with condensing boilers and furnaces. The pump should have an overflow switch to prevent property damage from condensate spillage. The switch should be wired to the auxiliary device proving switch terminals on the low voltage connection board.

Figure 9-1 Condensate Disposal

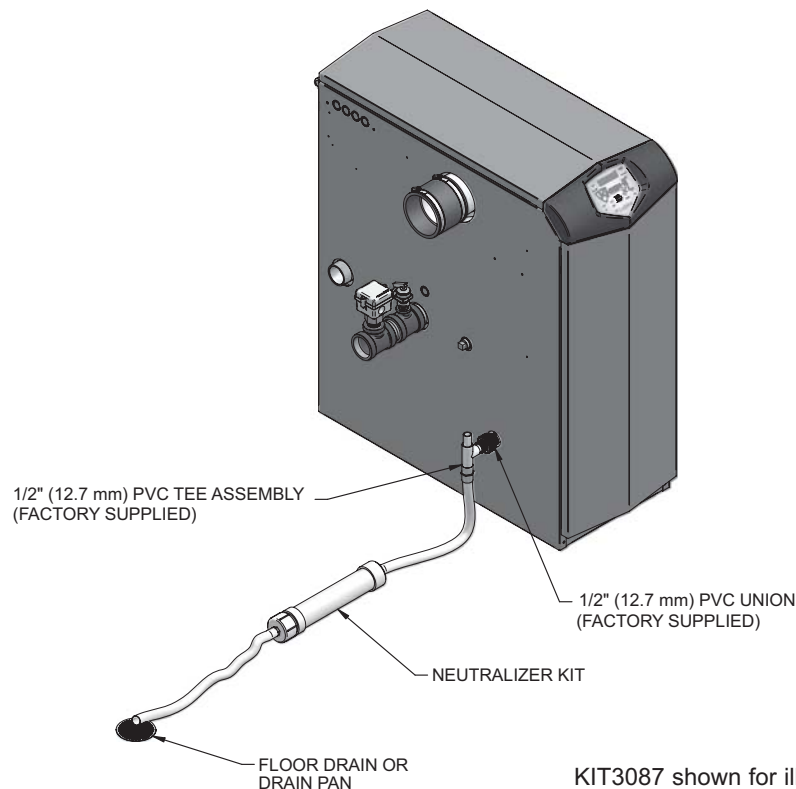

KIT3087 shown for illustration purposes.

10 Start-up

Check/control water chemistry

CAUTION Do not use petroleum-based cleaning or sealing compounds in the boiler system. Damage to elastomer seals and gaskets in the system could occur, resulting in substantial property damage.

Hardness less than 7 grains

1. Consult local water treatment companies for hard water areas (above 7 grains hardness).

Chlorine concentration less than 200 ppm

1. Do not fill boiler or operate with water containing chlorine in excess of 200 ppm.
2. Filling with chlorinated fresh water should be acceptable since drinking water chlorine levels are much lower.
3. Do not use the boiler to directly heat swimming pool or spa water.

Test/replace freeze protection fluid

1. For systems using freeze protection fluids, follow fluid manufacturer's instructions.
2. Freeze protection fluid must be replaced periodically due to degradation of inhibitors over time. Follow all fluid manufacturer's instructions.

Freeze protection (when used)

1. Determine freeze protection fluid quantity using system water content, following fluid manufacturer's instructions. Boiler water content is listed on page 7. Remember to include expansion tank water content.
2. Local codes may require a backflow preventer or actual disconnect from city water supply.
3. When using freeze protection fluid with automatic fill, install a water meter to monitor water makeup. Freeze protection fluid may leak before the water begins to leak, causing concentration to drop, reducing the freeze protection level.

Fill and test water system

1. Fill system only after ensuring the water meets the requirements of this manual.
2. Close manual and automatic air vents and boiler drain valve.
3. Fill to correct system pressure. Correct pressure will vary with each application.
 - a. The minimum cold water fill pressure for a commercial system is 12 psi (82.7 kPa).
 - b. Pressure will rise when boiler is turned on and system water temperature increases.

4. At initial fill and during boiler startup and testing, check system thoroughly for any leaks. Repair all leaks before proceeding further.

WARNING Eliminate all system leaks. Continual fresh makeup water will reduce boiler life. Minerals can build up in the heat exchanger, reducing heat transfer, overheating the heat exchanger, and causing heat exchanger failure.

Purge air from water system

1. Purge air from system:
 - a. Connect a hose to the purge valve (see purge/drain valves, in piping diagrams on page 39). Route the hose to an area where water can drain and be seen.
 - b. Close the boiler or system isolation valve between the purge valve and fill connection to the system.
 - c. Close zone isolation valves.
 - d. Open quick-fill valve on cold water makeup line.
 - e. Open purge valve.
 - f. One zone at a time, open the isolation valves. Allow water to run through the zone, pushing out the air. Run until no noticeable air flow is present. Close the zone isolation valves and proceed with the next zone. Follow this procedure until all zones are purged.
 - g. Close the quick-fill water valve and purge valve and remove the hose. Open all isolation valves. Watch that system pressure rises to correct cold-fill pressure.
 - h. After the system has operated for a while, eliminate any residual air by using the manual air vents located throughout the system.
 - i. If purge valves are not installed in the system, open the manual air vents in the system one at a time, beginning with the lowest floor. Close the vent when water squirts out. Repeat with remaining vents.
2. Open automatic air vent (diaphragm-type or bladder-type expansion tank systems only) one turn.
3. Open other vents:
 - a. Starting on the lowest floor, open air vents one at a time until water squirts out.
 - b. Repeat with remaining vents.
4. Refill to correct pressure.

10 Start-up *(continued)*

Check for gas leaks

⚠ WARNING Before starting the boiler, and during initial operation, smell near the floor and around the boiler for gas odorant or any unusual odor. Remove the top access panel and smell the interior of the boiler enclosure. Do not proceed with startup if there is any indication of a gas leak. Use an approved leak detection solution. Repair any leaks at once.

⚠ WARNING DO NOT adjust or attempt to measure gas valve outlet pressure. The gas valve is factory set for the correct outlet pressure. This setting is suitable for natural gas and propane, requiring no field adjustment. Attempting to alter or measure the gas valve outlet pressure could result in damage to the valve, causing potential severe personal injury, death, or substantial property damage.

Figure 10-1 Condensate Trap

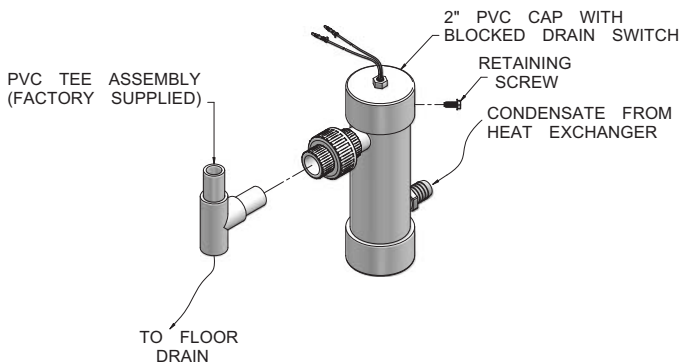

⚠ WARNING

Propane boilers only – Your propane supplier mixes an odorant with the propane to make its presence detectable. In some instances, the odorant can fade, and the gas may no longer have an odor. Before startup (and periodically thereafter), have the propane supplier verify the correct odorant level in the gas.

Check thermostat circuit(s)

1. Disconnect the two external wires connected to the room thermostat terminals on the connection board.
2. Connect a voltmeter across these two incoming wires. Close each thermostat, zone valve, and relay in the external circuit one at a time and check the voltmeter reading across the incoming wires.
3. There should NEVER be a voltage reading.
4. If a voltage does occur under any condition, check and correct the external wiring. (This is a common problem when using 3-wire zone valves.)
5. Once the external thermostat circuit wiring is checked and corrected if necessary, reconnect the external thermostat circuit wires to the connection board. Allow the boiler to cycle.

Inspect/fill condensate system

Inspect/check condensate lines and fittings

1. Inspect the condensate drain line, condensate PVC fittings and condensate trap.

Fill condensate trap with water

1. Remove the PVC cap retaining screw from the PVC cap (FIG. 10-1).
2. Remove the 2 inch PVC cap with the switch located at the top of the trap (FIG. 10-1).
3. Fill with fresh water until the water begins to pour out of the drain.
4. Replace the cap. Press the cap onto the trap until the cap makes contact with the drain.
5. Replace the retaining screw.

⚠ WARNING

The condensate trap (FIG. 10-1) must be filled with water during all times of boiler operation to avoid flue gas emission from the condensate drain line. Failure to fill the trap could result in severe personal injury or death.

10 Start-up

Final checks before starting the boiler

- ❑ Read the Knight XL Service Manual to familiarize yourself with SMART SYSTEM control module operation. Read this manual, page 51 for proper steps to start boiler.
- ❑ Verify the boiler and system are full of water and all system components are correctly set for operation.
- ❑ Verify the preparation procedures of Section 10, pages 48 and 49 have been completed.
- ❑ Fill the vent condensate trap with water (removing the retaining screw in order to remove the 2 inch PVC cap with the switch located at the top of the trap). Replace the cap. Press the cap onto the trap until the cap makes contact with the drain. Replace the retaining screw.
- ❑ Verify electrical connections are correct and securely attached.
- ❑ Inspect vent piping and air piping for signs of deterioration from corrosion, physical damage or sagging. Verify air piping and vent piping are intact and correctly installed per this manual.

Start the boiler

1. Read and follow the Operating instructions in FIG. 10-2, page 51.

If boiler does not start correctly

1. Check for loose connections, blown fuse or service switch off?
2. Is external limit control (if used) open? Is boiler water temperature above 200°F (93°C)?
3. Is thermostat set below room temperature?
4. Is gas turned on at meter or boiler?
5. Is incoming gas pressure less than 4 inches w.c. (.99 kPa)?

If none of the above corrects the problem, refer to the Troubleshooting Section of the Knight XL Service Manual.

Check system and boiler

❑ Check water piping

1. Check system piping for leaks. If found, shut down the boiler and repair immediately. (See WARNINGS on pages 48 and 49 (startup) regarding failure to repair leaks.)
2. Vent any remaining air from the system using manual vents. Air in the system will interfere with circulation and cause heat distribution problems and noise.

❑ Check vent piping and air piping

1. Check for gastight seal at every connection, seam of air piping, and vent piping.

⚠ WARNING

Venting system must be sealed gastight to prevent flue gas spillage and carbon monoxide emissions, which will result in severe personal injury or death.

❑ Check gas piping

1. Check around the boiler for gas odor following the procedure on page 39 of this manual (connecting gas supply piping).

⚠ WARNING

If you discover evidence of any gas leak, shut down the boiler at once. Find the leak source with a bubble test and repair immediately. Do not start the boiler again until corrected. Failure to comply could result in severe personal injury, death, or substantial property damage.

❑ Propane boilers – verify conversion

1. Verify propane conversion has been completed per the Propane Conversion instructions.

⚠ WARNING

DO NOT adjust or attempt to measure gas valve outlet pressure. The gas valve is factory-set for the correct outlet pressure. This setting is suitable for natural gas and propane, requiring no field adjustment. Attempting to alter or measure the gas valve outlet pressure could result in damage to the valve, causing potential severe personal injury, death, or substantial property damage.

⚠ WARNING

Knight XL boilers are typically shipped ready to fire on natural gas. Check boiler rating plate to determine which fuel the boiler is set for. If set to natural gas, it may be converted to LP by installing an orifice or by making a gas valve adjustment (see pages 12 and 13). In order to operate on LP gas, an orifice MUST BE installed or a gas valve adjustment MUST BE made. Failure to comply could result in severe personal injury, death, or substantial property damage.

Check flame and combustion

1. Turn the main power off to the boiler by placing the “On/Off” switch in the OFF position.
2. Remove the flue temperature sensor from the flue pipe connection. **Note:** Combustion measurements will be made at this point.
3. Turn the main power on to the boiler by placing the “On/Off” switch in the ON position.

10 Start-up *(continued)*

Figure 10-2 Operating Instructions

FOR YOUR SAFETY READ BEFORE OPERATING

WARNING: If you do not follow these instructions exactly, a fire or explosion may result causing property damage, personal injury, or loss of life.

- A. This appliance does not have a pilot. It is equipped with an ignition device which automatically lights the burner. Do not try to light the burner by hand.
 - B. BEFORE OPERATING smell all around the appliance area for gas. Be sure to smell next to the floor because some gas is heavier than air and will settle on the floor.
 - C. Use only your hand to turn the gas control knob. Never use tools. If the handle will not turn by hand, don't try to repair it, call a qualified service technician. Force or attempted repair may result in a fire or explosion.
 - D. Do not use this appliance if any part has been under water. Immediately call a qualified service technician to inspect the appliance and to replace any part of the control system and any gas control which has been under water.
- Immediately call your gas supplier from a neighbor's phone. Follow the gas supplier's instructions.
 - If you cannot reach your gas supplier, call the fire department.

WHAT TO DO IF YOU SMELL GAS

- Do not try to light any appliance.
- Do not touch any electric switch; do not use any phone in your building.

OPERATING INSTRUCTIONS

1. **STOP!** Read the safety information above on this label.
2. Set the thermostat to lowest setting.
3. Turn off all electric power to the appliance.
4. This appliance is equipped with an ignition device which automatically lights the burner. Do not try to light the burner by hand.
5. Remove top cover.
6. Turn gas shutoff valve counterclockwise to "OFF". Handle will be perpendicular to pipe. Do not force.
7. Wait five (5) minutes to clear out any gas. If you then smell gas, **STOP!** Follow "B" in the safety information above on this label. If you don't smell gas, go to next step.
8. Turn gas shutoff valve clockwise to "ON". Handle will be parallel to pipe.
9. Install top cover.
10. Turn on all electric power to appliance.
11. Set thermostat to desired setting.
12. If the appliance will not operate, follow the instructions "To Turn Off Gas To Appliance" and call your service technician or gas supplier.

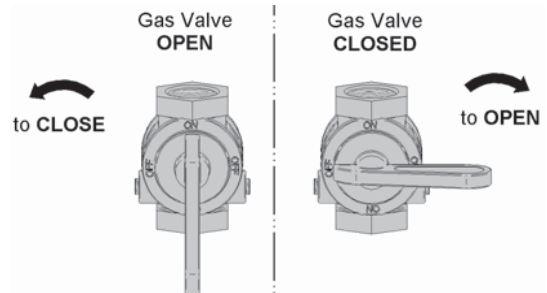

TO TURN OFF GAS TO APPLIANCE

1. Set the thermostat to lowest setting.
2. Turn off all electric power to the appliance if service is to be performed.
3. Remove top cover.
4. Turn gas shut off valve counterclockwise to "OFF". Handle will be perpendicular to pipe. Do not force.
5. Install top cover.

LBL2284 REV -

10 Start-up

Check flame and combustion *(continued)*

4. Place the boiler into the active position by pressing the SHUTDOWN button on the display board (FIG. 11-1, page 59) until **BLR: Standby** appears in the display window.
5. Locate the pinhole button above the “T” in the Knight XL logo on the display board (FIG. 11-1). Insert a thin wire (such as a paper clip) into the hole and press the button once and hold for 5 seconds to place the boiler into Service Mode. In Service Mode the boiler will fire at ignition speed and will then modulate up to full fire.
6. Insert the probe from a combustion analyzer into the hole left by the removal of the flue temperature sensor.
7. Once the boiler has modulated up to full fire, measure the combustion. The values should be in the range listed in Table 10A below. The CO levels should be less than 150 ppm for a properly installed unit.

If the combustion is not within the specified range, reference the Troubleshooting Section of the Knight XL Service Manual for possible causes and corrective actions.

Table 10A Flue Products Chart

Natural Gas		Propane	
CO ₂	O ₂	CO ₂	O ₂
8.0% - 10%	3.0% - 6.5%	9.0% - 11%	4.1% - 6.9%

8. Once the combustion analysis is complete, test the safety shutoff device by turning the manual shutoff valve to the OFF position and ensuring that the boiler shuts down and registers an alarm. Open the manual shutoff valve, reset the control, and return to Service Mode.
9. Turn the main power off to the boiler and replace the flue temperature sensor into the flue pipe connection.
10. Place the boiler back into normal operation.

⚠ WARNING

You must replace the flue gas temperature sensor to prevent flue gas spillage into the room. Failure to comply could result in severe personal injury, death, or substantial property damage.

Set space heating operation

Determine controlling sensor

For space heating systems, the temperature control can be based on one of three sensors; the inlet, outlet, or system supply sensor. The SMART SYSTEM control is programmed at the factory to control the temperature of the outlet sensor. The control will automatically switch to the system supply sensor once it is connected. If it is desired to base the temperature control on the inlet sensor, the appropriate parameter must be changed in the control. See the Knight XL Service Manual for a detailed explanation of this procedure.

Verify space heat circulator mode

The Space Heating Mode controls both the system (primary) pump (if connected), and the boiler (secondary) pump. When the SMART SYSTEM control receives a space heating call for heat, it turns on the system pump. If the boiler is not heating an indirect DHW (Domestic Hot Water) tank, it also turns on the boiler pump. After the space heating call for heat ends, the system pump continues to run for a short period of time. If the boiler pump was running, it continues to run for a short period of time as well. These pump delays are factory set to 30 seconds. If different delays are desired, the appropriate parameters in the control must be changed. See the Knight XL Service Manual for a detailed explanation of this procedure.

Set space heating set point temperature

The UP and DOWN keys may be used during normal operation to adjust the space heating set point temperature. Once the desired temperature is displayed, press the ENTER/RESET key to save the new setting. If the ENTER/RESET key is not pressed, the new setting will be used for the current heating cycle only. The old setting will become active after the current heating cycle ends.

10 Start-up *(continued)*

Set domestic hot water (DHW) operation

Verify DHW circulator mode

The DHW Mode is programmed to heat an indirect domestic hot water tank. When the tank thermostat calls for heat, the SMART SYSTEM control will turn on the DHW pump and turn off the boiler pump (if running). If the system pump is running, it will remain on. When the DHW call for heat ends, and there is no space heating call for heat, the DHW pump will continue to run for a period of time. This pump delay is set at the factory to 30 seconds. If a shorter or longer delay is desired, the appropriate parameter in the control must be changed. See the Knight XL Service Manual for a detailed explanation of this procedure. If there is an active space heating call for heat, then the boiler pump will be turned on and the DHW pump will be turned off.

Set DHW target temperature

When in the DHW Mode, the control will modulate to maintain the outlet temperature to a set point. This set point is set at the factory to 180°F. If a different set point is desired, the appropriate parameter in the control must be changed. See the Knight XL Service Manual for a detailed explanation of this procedure.

Set clock

The SMART SYSTEM control has a built-in clock that it uses for its night setback feature and for logging events. This clock must be set when the boiler is installed, and anytime the boiler has been powered off for more than one month. Use the following procedure to set the clock:

1. Press and hold the MENU key for at least 5 seconds.
2. The display changes to ready “ENTER MENU CODE”, with four (4) zeros below it.
3. Change the zeros to match the user code (factory set at “0704”). Use the UP and DOWN keys to increment or decrement the flashing digit, and the NEXT and PREVIOUS keys to select which digit flashes.
4. Press the ENTER key.
5. The display changes to read USER CODE for a few seconds, then displays a menu.
6. Press the ENTER key.
7. Press the UP key twice to display “A3 DATE AND TIME”.
8. Press the ENTER key once.

9. The date and time are displayed as “YY:MM:DD W hh:mm”, where:
 - mm: minutes
 - hh: hour (24 hour time; e.g., 2:00 PM = 14:00)
 - W: day of the week (1 = Monday, 2 = Tuesday, 3 = Wednesday, etc.,)
 - DD: date
 - MM: month
 - YY: year

NOTICE

The internal clock does not adjust for Daylight Savings Time and therefore, will require a manual adjustment.

Use the UP and DOWN keys to increment or decrement the flashing number, and the NEXT and PREVIOUS keys to select which number flashes.

10. Press the ENTER key to save the setting.
11. Press the MENU key twice to exit the Programming Mode.

Configuration of the cascade

When installed in a Cascade system, the individual controls must be programmed for cascade operation. This is accomplished by accessing the control parameters.

Input the Installer code as described in the Knight XL Service Manual. Once the control parameters have been accessed, use the DOWN arrow key to select the H Control Mode parameters. Press the ENTER key to access these parameters. Use the UP arrow key to access parameter H2 SH Source. Press the ENTER key to access this parameter. Use the DOWN arrow key to select Cascade. Press the ENTER key to program this into the control.

Press the UP arrow key to select the parameter H3 BLR Address. Press the ENTER key to access this parameter. Each unit in the Cascade system must be programmed with its own address. The boiler designated as the Leader will have an address of 0. The remaining boilers in the Cascade will be Members and have addresses from 1 - 7. Use the UP and DOWN arrow keys to select the appropriate address. Press the ENTER key to program this into the control.

Press the MENU key twice to exit the control parameters. Repeat this procedure for all boilers in the Cascade, designating the Leader control and the Member controls.

11 Operating information

General

How the boiler operates

The Knight XL uses an advanced stainless steel heat exchanger and electronic control module that allows fully condensing operation. The blower pulls in air and pushes flue products out of the boiler through the heat exchanger and flue piping. The control module regulates blower speed to control the boiler firing rate. The gas valve senses the amount of air flowing into the boiler and allows only the right amount of gas to flow.

How the control module operates

The SMART SYSTEM control module receives input from boiler sensors and external inputs. The control module activates and controls the blower and gas valve to regulate heat input and switches the boiler, Domestic Hot Water (DHW), and system pumps on and off as needed. The user programs the module to meet system needs by adjusting control parameters. These parameters set operating temperatures and boiler operating modes. Boiler operation can be based on boiler outlet water temperature, boiler inlet water temperature, or system temperature, depending on the parameter setting.

Control inputs and outputs

Room thermostat / zone control

This input tells the boiler to provide water for space heating.

Domestic Hot Water (DHW) tank thermostat

This input tells the boiler to provide water for heating an indirect DHW tank.

0 - 10V input (set point or power)

The Knight XL can be controlled by a Building Management System (BMS) using a 0 - 10 VDC signal. The control can be configured by the installer to use this signal to either control set point or firing rate.

DHW priority

The SMART SYSTEM control module allows connection of a DHW thermostat to the low voltage connection board. When the DHW thermostat calls for heat, the module activates the DHW pump, shuts down the boiler pump, and immediately sets the target outlet water temperature to 180°F (82.2°C). This provides automatic priority heat allocation to the indirect water heater for maximum response and recovery. The DHW pump continues for 30 seconds after the heating cycle to deliver the most possible heat.

DHW / space heating (SH) cycling

If a DHW call for heat is received while a space heating call is in progress, the control will start the DHW pump and shut the boiler pump off. The system pump will remain on. If the space heating call is still active while the DHW call is in operation, the control will wait for 30 minutes (time adjustable by installer) then it will switch back to the space heating demand. The control will switch back and forth until one of the heat demands end. This function does not apply to cascade systems.

Programmable controlling sensor

The control module is programmed to use the outlet sensor as the control sensor by default. If a system supply sensor is connected, the control automatically uses it as the control sensor. The control sensor can be changed by the installer to the inlet sensor. If the inlet sensor is chosen as the controlling sensor, it is recommended that the system supply sensor be installed.

Anti-cycling

After a space heating demand has been satisfied, the control will delay the next space heating call for a set time period (time is adjustable by the installer). The time delay will be bypassed if the inlet water temperature drops too far during the delay.

Boiler, system, and DHW pump control

When a space heating call for heat starts and no DHW call is on, the system and boiler pumps are turned on. As long as the space heating call for heat is on, the system pump will remain on. If a DHW call for heat is on, the boiler pump will wait to turn on until just before the DHW pump turns off. After the space heating call for heat ends, both pumps will run for an additional period of time.

When a DHW call for heat starts, the DHW pump is turned on. If a space heating call for heat was on, the boiler pump will turn off a few seconds after the DHW pump turns on.

Temperature control

Modulation

The Knight XL is capable of modulating its firing rate from a minimum of 20% to a maximum of 100%. The firing rate is dictated by the call for heat (i.e., space heating or domestic hot water), the heating load, ramp delay (if enabled), and various other temperature limitations.

11 Operating information *(continued)*

Ramp delay

For systems with lower flow, the SMART SYSTEM can limit the firing rate (when enabled) when a space heating call for heat starts, or when switching from a DHW call for heat to a space heating call for heat. There are six (6) limits that can be programmed, as well as six (6) time intervals corresponding to each limit. The sixth limit will also limit the firing rate for the rest of the call for heat.

Gradient limiting

If during operation of the boiler the outlet water temperature is rising too quickly, the control will reduce the firing rate to its lowest setting.

Outdoor air reset

If an outdoor air sensor is connected, the control module will calculate the set point based on the programmed reset curve. The installer can change the slope of the reset curve by several adjustable parameters. The user can limit the maximum set point for the system using the space heating set point.

Boost function

If outdoor air reset is active, and a space heating demand has been active continuously for a set period of time (time adjustable by installer) and there has been no DHW demands, the control will increase the set point by a fixed number of degrees (adjustable by installer). This process will continue until the space heating demand ends, the set point reaches the programmed set point or a maximum of 20 increases has occurred. Once the system heat demand is satisfied, the set point will revert to the value determined by the reset curve.

Night setback

The controller may be programmed to reduce the space heating set point during a certain time each day. A start and stop time can be programmed for each day of the week.

Flame current support

To prevent nuisance shutdowns when the boiler is firing at minimum rates, the control will increase the firing rate when the flame signal drops too low.

Protection features

Outlet temperature, flue temperature, and temperature rise limiting

The outlet temperature is monitored by the boiler outlet temperature sensor. When the outlet temperature exceeds 185°F, the unit will reduce the fan speed. If the outlet water temperature exceeds 195°F (90°C) the control will shut the unit down until it cools off.

The control module monitors the flue temperature by a sensor located in the flue exhaust. If the flue temperature exceeds 215°F (102°C) the control will reduce the maximum fan speed. If the flue temperature exceeds 240°F (115°C) the control will shut the unit down. The unit will restart automatically once the flue temperature drops 25°F (-4°C) and the minimum off time has expired.

The control monitors the temperature difference between the inlet and the outlet sensor. If this difference exceeds 55°F (13°C) the control will reduce the fan speed. If the temperature difference exceeds 60°F (15°C) the control will shut the unit down. The unit will restart automatically once the temperature difference has dropped below 55°F (13°C) and the minimum off time has expired.

Freeze protection

DO NOT install the boiler in a room likely to freeze.

The following integral feature of the SMART SYSTEM control module provides some protection for the boiler only -- not for the system.

- The SMART SYSTEM control module provides freeze-up protection as follows when the boiler water temperature drops below 45°F (7°C):
- Below 45°F (7°C), the boiler and system pumps operate constantly.
- Below 37°F (3°C), the boiler turns on.
- Boiler and pumps turn off if boiler water temperature rises above 45°F (7°C).

⚠ CAUTION

This feature of the SMART SYSTEM control module does not eliminate the possibility of freezing. The installation must still use recognized design, installation and maintenance practice to prevent freeze potential for the boiler and system.

11 Operating information

Monitor external limits

Connections are provided on the connection board for external limits such as flow switch, low water cutoff, gas pressure switches, and an auxiliary device proving switch. The SMART SYSTEM will shut off the burner and inhibit relighting whenever any of these external limits open.

Run-time and alarm outputs

The boiler provides dry contacts for indicating when the boiler is running, and when it is unable to operate.

Run-time and cycle counting

The control uses two timers to monitor the total hours of burner operation. One timer monitors the time the boiler is firing under 50% of rate. The other timer monitors the time the boiler is firing over 50% rate.

The control uses four (4) ignition counters to monitor the amount of boiler cycles. The first counter counts all ignitions of the control. The second counter counts only ignition attempts that have failed. The third and fourth counters are the same as the first and second respectively, but can be reset by the installer.

Service reminder

The control can be programmed for service reminder notification. This notification will become active when either a set time frame has expired, or a set amount of running hours or cycles has expired (all adjustable by the installer). The display will alternate the standard text on the display screen with Service Due every 5 seconds. The service reminder notification can be reset by the installer.

Error logging

The control will hold in memory the last 10 error codes as well as the last 10 turn-off functions. The date and time of the occurrence will be recorded as well. Only the 10 most current occurrences will be held in memory.

Boiler temperature regulation

Operating temperature (target)

The SMART SYSTEM control module senses water temperature and regulates boiler firing and firing rate to achieve a target temperature. The target temperature can be set between 70°F (21°C) and 190°F (88°C).

- Target temperature is fixed when the outdoor sensor is not installed.
- Target temperature is calculated as described on this page under “Outdoor Reset Operation” and “Target Temperature Boost” when the outdoor sensor is connected.

High limit operations

When outlet temperature exceeds 200°F (93.3°C), high limit action occurs. The boiler shuts down until the outlet water cools down.

Low water cutoff protection

1. The SMART SYSTEM control module uses temperature sensing of both supply and return areas of the heat exchanger. If the flow rate is too low or the outlet temperature too high, the control module modulates and shuts the boiler down. This ensures boiler shutdown in the event of low water or low flow conditions.
2. Some codes and jurisdiction may accept these integral features of the control in lieu of requiring an additional limit control or low water cutoff. Consult local jurisdiction to determine. Low water cutoff kits are available (KIT3055 and 3057).

Outdoor reset operation, if used

Target temperature with outdoor reset

This feature improves the system’s efficiency as the outdoor temperature warms up.

See the Knight XL Service Manual to change the settings.

Reset curve

The reset curve looks at outdoor air temperature and adjusts the set point.

Cascade

When multiple boilers are installed, they can be wired together in a cascade sequence. A maximum of eight boilers can be controlled from a single control. In this application one boiler would be designated as the Leader control and all others would be designated as Member controls.

Once the Leader boiler receives a call for heat from a room thermostat, the control will determine what the set point will be. If outdoor air reset is desired, connect the outdoor air sensor to the terminals on the Low Voltage Connection Board on the Leader boiler. The set point will be calculated based on the programmed reset curve parameters. See the Knight XL Service Manual to program the reset curve. If outdoor air reset is not desired, do not connect the outdoor air sensor. A fixed temperature set point can be programmed into the control. See page 52 of this manual to program the set point.

11 Operating information *(continued)*

Cascade *(continued)*

If the water temperature at the system supply sensor is less than the set point + the turn-off offset - the off-on differential, then the control will initiate a call for heat on the Cascade (see the Knight XL Service Manual for an explanation of the offset and differential). The Leader will energize the lead boiler on the Cascade. For a new startup this will be the Leader boiler.

The boiler will fire at its ignition speed and will then modulate its firing rate to maintain the set point. If the first boiler reaches 100% of its firing rate, the Leader will calculate at what point the second boiler could fire at 20% of its firing rate. At this point, the Leader will fire the second boiler on the Cascade. For a new startup, this would be the first Member boiler. The boiler will fire at its ignition speed and will then modulate its firing rate to maintain the set point.

If the set point still cannot be met, the Leader will continue firing more Members until either the heat demand is met or all boilers on the Cascade are firing. As the heat demand decreases, the last boiler on will modulate down to 20% of its firing rate. Once the demand for that boiler is zero, it will shut down. As the heat demand decreases further, the second to last boiler will modulate down and shut off. This will continue until the demand is satisfied and all boilers are shut off.

Sequence of the cascade

To equalize the run time of all boilers on the Cascade, the firing sequence will automatically be changed at set intervals.

For the first 24 hours after initializing the Cascade, the sequence will be changed every hour. After that the sequence will be changed once every 24 hours. The switching on/off sequence will be as follows:

DAY	SWITCHING ON SEQUENCE
Day 1	L-M1-M2-M3-M4-M5-M6-M7
Day 1 + 1 hour	M1-M2-M3-M4-M5-M6-M7-L
Day 1 + 2 hours	M2-M3-M4-M5-M6-M7-L-M1

DHW, Night Setback, and Ramp Delay operation with cascade

For DHW operation any boiler(s) in the Cascade can be selected to provide heat for a DHW call. Select a boiler to be designated as the DHW boiler. Connect the DHW thermostat to the terminals on the Low Voltage Connection Board marked for the DHW Thermostat. When the boiler receives a DHW call, the Leader control will take that boiler out of the Cascade sequence. If another boiler is available, the Leader will start it up to take its place.

The DHW boiler will adjust its set point to the programmed DHW set point and will adjust its firing rate to maintain this. Once the DHW call has been satisfied, the Leader control will place that boiler back into the Cascade sequence.

Switching of the boiler between DHW operation and SH operation when there is a call for both does not occur. The boiler will provide heat for the DHW demand until it is satisfied.

Night Setback operation of the boilers within the Cascade is available. Programming of the Night Setback will be done through the Leader boiler. Refer to the Knight XL Service manual for information regarding Night Setback.

Ramp Delay operation of the boilers as described in the Knight XL Service Manual is not active when the boilers are part of a Cascade system.

11 Operating information

Sequence of operation

OPERATION	DISPLAY
1. Upon a call for heat, the control turns on the appropriate pumps (system and boiler pumps for space heating call; DHW pump for DHW call).	BLR: Standby OUT: 123.8F (129)
2. The control connects 120 VAC to the blower. The blower does not run at this time. <ul style="list-style-type: none"> • The manual reset high limit must be closed and reset. • Once the pumps are turned on, the flow switch must close. • If the unit is equipped with gas pressure switches, they must close. • If an auxiliary limit is connected to the unit, it must close. • The air pressure switch must be closed. 	BLR: Standby OUT: 123.8F (129)
3. The control then starts a 15 second prepurge cycle.	BLR: PREPURGE OUT: 123.9F (129)
4. Once the prepurge cycle is complete, and the blocked drain switch is closed, the control starts the 4 second trial for ignition by sending spark voltage to the spark electrode and opening the gas valve.	BLR: IGNITION OUT: 123.9F (129)
5. If the control does not detect flame before the trial for ignition ends, the control will perform a 10 second postpurge. The 399 model will start another prepurge and trial for ignition. If the burner does not light after 4 trials on the 399 model, the control will lock out for one hour and then try again. On the 500 - 800 models, the control will lock out indefinitely after the first trial for ignition fails.	BLR: POSTPURGE, PREPURGE OUT: 123.9F (129)
6. If the control detects a flame before the trial for ignition ends, it begins to modulate the burner in order to maintain the set point. If the boiler lights due to a space heating call for heat, and the ramp delay function is active (default is off), the modulation will be held to a series of increasing limits after the burner has lit.	BLR: SH 20% RATE OUT: 124.8F (129)
7. If the space heating call for heat is active, and the DHW thermostat or sensor starts a DHW call for heat, the control will turn on the DHW pump, wait 2 seconds, and then turn off the boiler pump. This will divert the hot water away from the heating zone(s) and send it to the DHW tank instead. The control will then modulate to maintain the outlet temperature to the DHW boiler set point.	BLR: DHW 85% RATE OUT: 177.8 (180)
8. If the boiler is not part of a cascade, and the DHW call for heat remains active for more than 30 minutes, and the space heating call for heat is also active, then the control will turn on the boiler pump, turn off the DHW pump after 2 seconds, and resume modulating based on the space heating set point. As long as both the space heating and DHW calls for heat remain active, the control will switch back and forth between the two modes until one of them is satisfied.	BLR: SH 41% RATE OUT: 123.0F (129)
9. Once both calls for heat are satisfied, the control will turn off the burner. The blower will remain on for the 10 second postpurge cycle. Any pumps that are running will continue to run for their respective pump delay times, then turn off.	BLR: POSTPURGE OUT: 127.4F (129)
10. Boiler pump off, system pump continues its delay if longer.	BLR: Standby OUT: 124.7F (129)
11. System pump off.	BLR: Standby OUT: 122.9F (129)

11 Operating information *(continued)*

SMART SYSTEM™ Knight XL control module

Use the control panel (FIG. 11-1) to set temperatures, operating conditions, and monitor boiler operation.

Figure 11-1 Control Panel

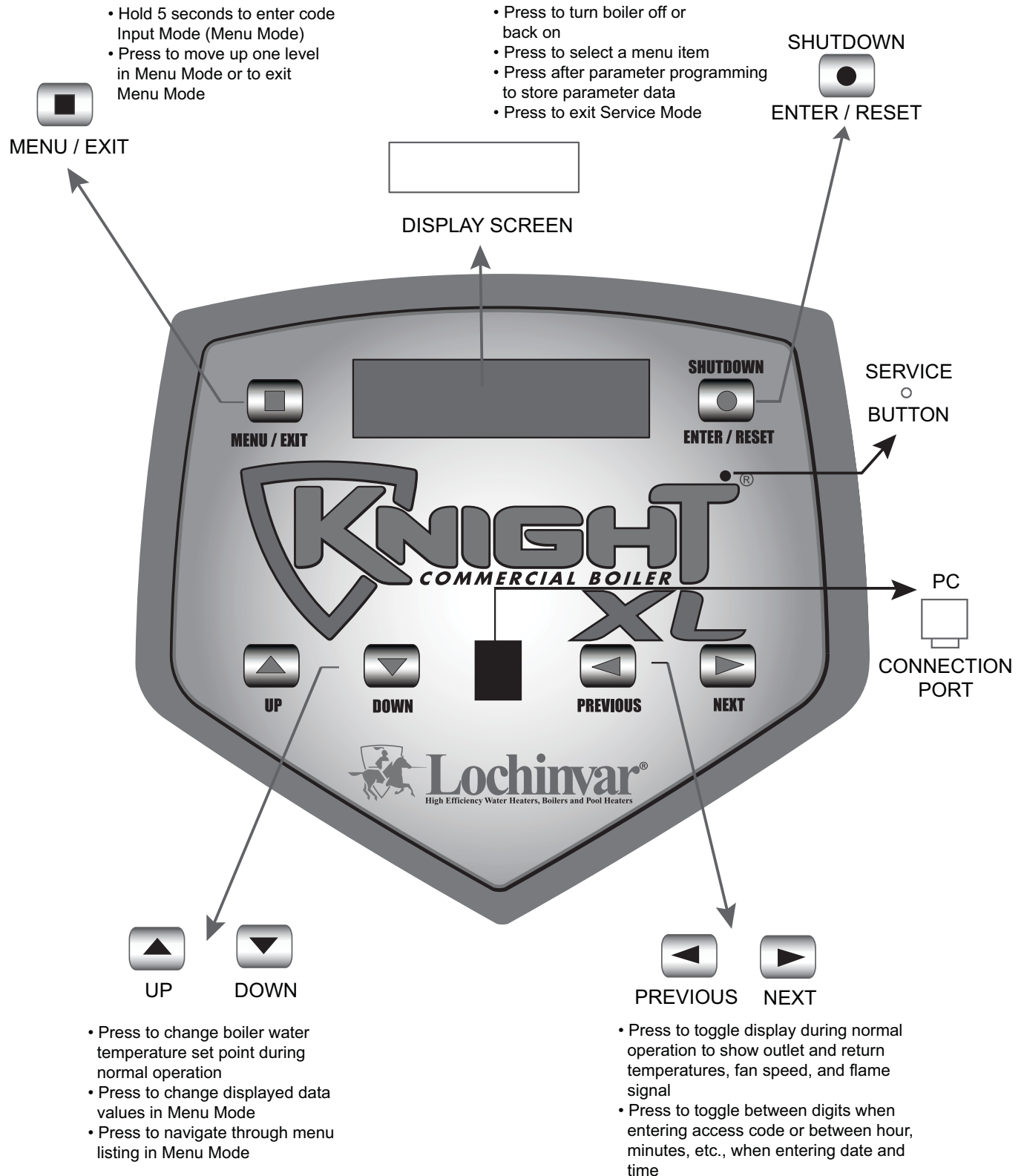

11 Operating information

Access modes

User

The user can adjust space heating target temperature by using the UP and DOWN buttons (FIG. 11-1) at any time during normal operation. By entering the USER code (0704), the user can also change temperature units, time and date, and night setback settings. In User Mode, the following parameters can be viewed but not changed:

- Boiler outlet water target temperature in DHW Mode
- Boiler model number
- Software version
- Total operating hours
- Total cycles

Installer

Most parameters are available only to the installer, accessible only by entering the installer access code, see the Knight XL Service Manual.

Saving parameters (*reference the Parameter Table in the Knight XL Service Manual*)

To save parameters and exit programming:

Press the ENTER/RESET button.

To keep parameter settings only for a current operating cycle:

Press the MENU/EXIT button 3 times after making all desired parameter changes.

To enter a parameter and continue programming:

Press the MENU/EXIT button 1 time to return to the parameter listings; press again to return to the menu listings. Remember to press the ENTER/RESET button when finished programming in order to save the changes made.

See the Knight XL Service Manual for a detailed description of parameters and access modes.

11 Operating information *(continued)*

Status Display Screens		
By using the Previous/Next (◀, ▶) arrow keys on the SMART SYSTEM display panel, you can navigate through the eight (8) display screens. Each screen will contain two (2) viewable items. The following is a description of the individual items and what they can display:		
Screen	Display shows:	Description
#1	BLR: OFF	The unit has been turned OFF by the Enter/Reset button on the SMART SYSTEM display panel.
	Standby	The unit has not received a call for heat from a remote thermostat nor has it received a call for heat from a DHW thermostat.
	Set Point Met	The unit has met the water temperature set point, but is still receiving a call for heat from either a remote thermostat or a DHW thermostat.
	Prepurge	The unit has initiated a 10 second purge period on a call for heat. Note: On the 800 model the unit will initiate a 20 second purge period on a call for heat.
	Ignition	The unit has begun a 5 second spark period to ignite the main burner.
	SH***% Rate	The unit has fired and is running at the displayed percentage.
	Postpurge	The call for heat has been satisfied and the unit runs the fan for an additional 10 seconds to clear the combustion chamber and vent system of residual flue products.
	Service	The unit has been placed in a temporary mode that will allow the unit to fire at 100% of rate for the purpose of combustion analysis.
	OUT: ***.*F(***)	When the outlet sensor has been selected as the control sensor (default), the control will display the outlet temperature as well as the set point in parenthesis.
	***.*F	If the outlet sensor has not been selected as the control sensor, only the outlet temperature will be displayed.
	Open	The control does not detect the outlet sensor.
Shorted	The outlet sensor wires or the sensor itself has become shorted.	
Press the Next ▶ arrow key on the SMART SYSTEM display to access Screen #2.		
#2	IN: ***.*F	If the inlet sensor has not been selected as the control sensor, only the inlet temperature will be displayed.
	.*F ()	When the inlet sensor has been selected as the control sensor, the control will display the inlet temperature as well as the set point in parenthesis.
	Open	The control does not detect the inlet sensor.
	Shorted	The inlet sensor wires or the sensor itself has become shorted.
	RISE: ***.*F	The difference between the inlet temperature and the outlet temperature.
Press the Next ▶ arrow key on the SMART SYSTEM display to access Screen #3.		

11 Operating information

Status Display Screens (cont'd)

By using the Previous/Next (◀, ▶) arrow keys on the SMART SYSTEM display panel, you can navigate through the eight (8) display screens. Each screen will contain two (2) viewable items. The following is a description of the individual items and what they can display:

Screen	Display shows:	Description
#3	SYS: ***.°F	If the system supply sensor has not been selected as the control sensor, only the system temperature will be displayed.
	.°F ()	When the system supply sensor has been selected as the control sensor, the control will display the system temperature as well as the set point in parenthesis.
	Open	The control does not detect the system supply sensor.
	Shorted	The system supply sensor wires or the sensor itself has become shorted.
	OUTDOOR: ***.°F	The control will display the outdoor air temperature as sensed by the outdoor air sensor.
	Open	The control does not detect the outdoor air sensor.
	Shorted	The outdoor air sensor wires or the sensor itself has become shorted.
Press the Next ▶ arrow key on the SMART SYSTEM display to access Screen #4.		
#4	FLUE: ***.°F	The control will display the flue temperature.
	Open	The control does not detect the flue sensor.
	Shorted	The flue sensor wires or the sensor itself has become shorted.
	AUX: ***.°F	The control will display the temperature.
	Open	The control does not detect the auxiliary sensor.
	Shorted	The auxiliary sensor wires or the sensor itself has become shorted.
Press the Next ▶ arrow key on the SMART SYSTEM display to access Screen #5.		
#5	FAN SPD: ****RPM	The control will display the actual fan motor RPM.
	FLAME SIG: **, *uA	The control will display the flame signal in dc microamps.
Press the Next ▶ arrow key on the SMART SYSTEM display to access Screen #6.		
#6	SH CFH: OFF	The control has not received a call for heat from a remote thermostat.
	ON	The control has received a call for heat from a remote thermostat.
	DHW CFH: OFF	The control has not received a call for heat from a SH remote thermostat.
	ON	The control has received a call for heat from a DHW thermostat.
Press the Next ▶ arrow key on the SMART SYSTEM display to access Screen #7.		

11 Operating information *(continued)*

Status Display Screens <i>(cont'd)</i>		
By using the Previous/Next (◀, ▶) arrow keys on the SMART SYSTEM display panel, you can navigate through the eight (8) display screens. Each screen will contain two (2) viewable items. The following is a description of the individual items and what they can display:		
Screen	Display shows:	Description
#7	DHW PUMP: OFF	The control has not received a DHW call for heat and has not powered the DHW pump.
	ON	The control has received a DHW call for heat and has powered the DHW pump.
	Delay	The DHW call for heat has been satisfied and the DHW pump is running for a fixed time to remove any residual heat.
	0-10V IN: **.Vdc	The control will display a 0-10Vdc signal received from a Building Management System (BMS) connected to the unit.
Press the Next ▶ arrow key on the SMART SYSTEM display to access Screen #8.		
#8	SYS PUMP: OFF	The control has not received a call for heat from a remote thermostat and has not powered the system pump.
	ON	The control has received a call for heat from a remote thermostat and has powered the system pump.
	Delay	The system call for heat has been satisfied and the system pump is running for a fixed time to remove any residual heat.
	BLR PUMP: OFF	The control has either not received a call for heat from a remote thermostat, a remote thermostat is not connected to the unit and the water temperature has not dropped below the temperature set point of the control to initiate a call for heat, or the control has received a DHW call for heat from a DHW thermostat.
	ON	The control has received a call for heat from a remote thermostat or a remote thermostat is not connected and the water temperature has dropped below the temperature set point of the control to initiate a call for heat.
	Delay	The call for heat has been satisfied and the boiler pump is running for a fixed time to remove any residual heat.
Press the Next ▶ arrow key on the SMART SYSTEM display to access Screen #9.		

11 Operating information

Status Display Screens (cont'd)

Operation of the cascade

The boiler designated as the Leader will have two additional display screens that can be viewed. These screens will provide information regarding the operation of the Cascade. Each screen will contain two viewable items. The following is a description of the individual items and what they can display:

Screen	Display shows:	Description
#9	Cas: Off	The Leader control has been turned off by the Enter/Reset button on the Smart System display.
	Cas: Standby	The Leader boiler has not received a call for heat from a remote thermostat.
	Cas: 127.4F (130)	The Cascade is now active. The system supply temperature will be displayed. The Cascade set point will be displayed in parenthesis.
	Cas: Setpoint Met	The Cascade has met the water temperature set point, but is still receiving a call for heat from a remote thermostat.
	Cas: No Members	The Leader control could not detect any Member controls to participate in the Cascade.
	Cas: S6 Not Present	The system supply sensor is not connected to the Leader boiler.
	PMP: Off	The Leader control has not received a call for heat from a remote thermostat and has not powered the system pump.
	PMP: On	The Leader control has received a call for heat from a remote thermostat and has powered the system pump.
	PMP: Delay	The system call for heat has been satisfied and the system pump is running for a fixed time to remove any residual heat.

Press the Next ► arrow key on the SMART SYSTEM display to access Screen #10.

#10	Cas Pow: ***% ***%	The first percentage shows the firing rate that is being sent to the last boiler called on. The second percentage shows the total power available to the Cascade.
	Present: 01234567 Example: Present: 23----d1	Shows the number of boilers connected to the Cascade. The Leader is designated as 0. Members will be designated 1 - 7. If a “-” is used in place of a number, that boiler is either not connected, or in a lockout mode and not available for the Cascade. If a “d” is used in place of a number, that boiler is handling a DHW demand and is not available for the Cascade. If the number is flashing, then that boiler is providing heat to the Cascade. As the lead boiler is changed from day to day, that boiler’s address will be shown first in the string of numbers. In the example, boilers 0 - 3 are present, boiler 2 is the lead boiler, and boiler 0 is heating an indirect DHW tank.

Press the Next ► arrow key on the SMART SYSTEM display to roll back to Screen #1. At any point if you wish to access an earlier screen, press the Previous ◀ arrow key on the SMART SYSTEM display.

12 Maintenance

Maintenance and annual startup

Table 12A Service and Maintenance Schedules

Service technician (see the following pages for instructions)		Owner maintenance (see the Knight XL User's Information Manual for instructions)	
ANNUAL START-UP	<p>General:</p> <ul style="list-style-type: none"> • Address reported problems • Inspect interior; clean and vacuum if necessary; • Clean condensate trap and fill with fresh water • Check for leaks (water, gas, flue, condensate) • Verify flue and air lines in good condition and sealed tight • Check system water pressure/system piping/expansion tank • Check control settings • Check ignition and flame sense electrodes (sand off any deposits; clean and reposition) • Check wiring and connections • Perform start-up checkout and performance verification per Section 10. • Flame inspection (stable, uniform) • Flame signal (at least 10 microamps at high fire) • Clean the heat exchanger if flue temperature is more than 54°F (30°C) above return water temperature. <p>If combustion or performance indicate need:</p> <ul style="list-style-type: none"> • Clean heat exchanger • Remove and clean burner using compressed air only • Clean the blower wheel 	Daily	<ul style="list-style-type: none"> • Check boiler area • Check pressure/temperature gauge
		Monthly	<ul style="list-style-type: none"> • Check vent piping • Check air piping • Check air and vent termination screens • Check relief valve • Check condensate drain system • Check automatic air vents
		Periodically	<ul style="list-style-type: none"> • Test low water cutoff (if used) • Reset button (low water cutoff)
		Every 6 months	<ul style="list-style-type: none"> • Check boiler piping (gas and water) for leaks • Operate relief valve
		End of season months	<ul style="list-style-type: none"> • Shut boiler down (unless boiler used for domestic hot water)

12 Maintenance

⚠ WARNING Follow the Service and maintenance procedures given throughout this manual and in component literature shipped with the boiler. Failure to perform the service and maintenance could result in damage to the boiler or system. Failure to follow the directions in this manual and component literature could result in severe personal injury, death, or substantial property damage.

⚠ WARNING The boiler should be inspected annually only by a qualified service technician. In addition, the maintenance and care of the boiler designated in Table 12A and explained on the following pages must be performed to assure maximum boiler efficiency and reliability. Failure to service and maintain the boiler and system could result in equipment failure.

⚠ WARNING Electrical shock hazard – Turn off power to the boiler before any service operation on the boiler except as noted otherwise in this instruction manual. Failure to turn off electrical power could result in electrical shock, causing severe personal injury or death.

Address reported problems

1. Inspect any problems reported by the owner and correct before proceeding.

Inspect boiler area

1. Verify that boiler area is free of any combustible materials, gasoline and other flammable vapors and liquids.
2. Verify that air intake area is free of any of the contaminants listed in Section 1 of this manual. If any of these are present in the boiler intake air vicinity, they must be removed. If they cannot be removed, reinstall the air and vent lines per this manual and the Knight XL Service Manual.

Inspect boiler interior

1. Remove the front access cover and inspect the interior of the boiler.
2. Vacuum any sediment from inside the boiler and components. Remove any obstructions.

Clean condensate trap

1. Inspect the condensate drain line, condensate PVC fittings, and condensate trap.
2. Remove the PVC cap retaining screw from the PVC cap (FIG. 12-1).
3. Remove the 2 inch PVC cap with the switch located at the top of the trap (FIG. 12-1).
4. Remove any sediment in the trap.
5. Fill with fresh water until the water begins to pour out of the drain.
6. Replace the cap. Press the cap onto the trap until the cap makes contact with the drain.
7. Replace the retaining screw.

Figure 12-1 Condensate Trap

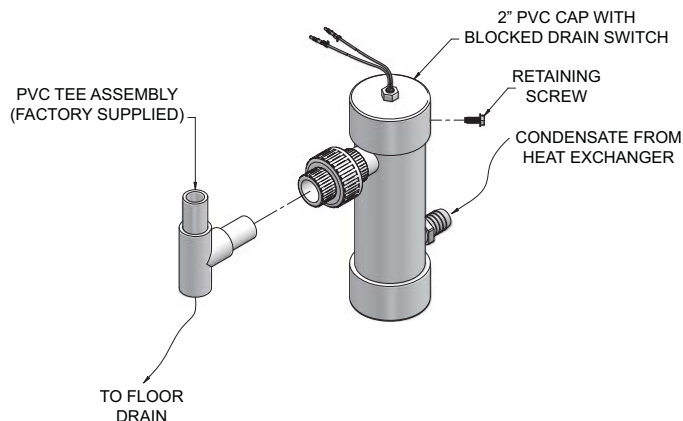

⚠ WARNING The condensate trap must be filled with water during all times of boiler operation to avoid flue gas emission from the condensate drain line. Failure to fill the trap could result in severe personal injury or death.

Check all piping for leaks

⚠ WARNING Eliminate all system or boiler leaks. Continual fresh makeup water will reduce boiler life. Minerals can build up in sections, reducing heat transfer, overheating heat exchanger, and causing heat exchanger failure. Leaking water may also cause severe property damage.

1. Inspect all water and gas piping and verify to be leak free.
2. Look for signs of leaking lines and correct any problems found.
3. Check gas line using the procedure found in Section 7 - Gas Connections.

12 Maintenance *(continued)*

Flue vent system and air piping

1. Visually inspect the entire flue gas venting system and air piping for blockage, deterioration or leakage. Repair any joints that show signs of leakage. Verify that air inlet pipe is connected and properly sealed.
2. Verify that boiler vent discharge and air intake are clean and free of obstructions.

⚠ WARNING Failure to inspect for the above conditions and have them repaired can result in severe personal injury or death.

Check water system

1. Verify all system components are correctly installed and operational.
2. Check the cold fill pressure for the system. Verify it is correct (must be a minimum of 12 psi (82.7 kPa)).
3. Watch the system pressure as the boiler heats up (during testing) to ensure pressure does not rise too high. Excessive pressure rise indicates expansion tank sizing or performance problem.
4. Inspect automatic air vents and air separators. Remove air vent caps and briefly press push valve to flush vent. Replace caps. Make sure vents do not leak. Replace any leaking vents.

Check expansion tank

1. Expansion tanks provide space for water to move in and out as the heating system water expands due to temperature increase or contracts as the water cools. Tanks may be open, closed or diaphragm or bladder type. See Section 6 - Hydronic Piping for suggested best location of expansion tanks and air eliminators.

Check boiler relief valve

1. Inspect the relief valve and lift the lever to verify flow. Before operating any relief valve, ensure that it is piped with its discharge in a safe area to avoid severe scald potential. Read Section 6 - Hydronic Piping before proceeding further.

⚠ WARNING

Safety relief valves should be re-inspected AT LEAST ONCE EVERY THREE YEARS, by a licensed plumbing contractor or authorized inspection agency, to ensure that the product has not been affected by corrosive water conditions and to ensure that the valve and discharge line have not been altered or tampered with illegally. Certain naturally occurring conditions may corrode the valve or its components over time, rendering the valve inoperative. Such conditions are not detectable unless the valve and its components are physically removed and inspected. This inspection must only be conducted by a plumbing contractor or authorized inspection agency – not by the owner. Failure to re-inspect the boiler relief valve as directed could result in unsafe pressure buildup, which can result in severe personal injury, death, or substantial property damage.

⚠ WARNING

Following installation, the valve lever must be operated AT LEAST ONCE A YEAR to ensure that waterways are clear. Certain naturally occurring mineral deposits may adhere to the valve, rendering it inoperative. When manually operating the lever, water will discharge and precautions must be taken to avoid contact with hot water and to avoid water damage. Before operating lever, check to see that a discharge line is connected to this valve directing the flow of hot water from the valve to a proper place of disposal. Otherwise severe personal injury may result. If no water flows, valve is inoperative. Shut down the boiler until a new relief valve has been installed.

2. After following the above warning directions, if the relief valve weeps or will not seat properly, replace the relief valve. Ensure that the reason for relief valve weeping is the valve and not over-pressurization of the system due to expansion tank waterlogging or undersizing.

12 Maintenance

Inspect ignition and flame sense electrodes

1. Remove the ignition and flame sense electrodes from the boiler heat exchanger access cover.
2. Remove any deposits accumulated on the ignition/flame sense electrode using sandpaper. If the electrodes cannot be cleaned satisfactorily, replace with new ones.
3. Replace ignition/flame sense electrode, making sure gasket is in good condition and correctly positioned.

Check ignition ground wiring

1. Inspect boiler ground wire from the heat exchanger access cover to ground terminal strip.
2. Verify all wiring is in good condition and securely attached.
3. Check ground continuity of wiring using continuity meter.
4. Replace ground wires if ground continuity is not satisfactory.

Check all boiler wiring

1. Inspect all boiler wiring, making sure wires are in good condition and securely attached.

Check control settings

1. Set the SMART SYSTEM control module display to Parameter Mode and check all settings. See Section 1 of the Knight XL Service Manual. Adjust settings if necessary. See Section 1 of the Knight XL Service Manual for adjustment procedures.
2. Check settings of external limit controls (if any) and adjust if necessary.

Perform start-up and checks

1. Start boiler and perform checks and tests specified in Section 10 - Start-up.
2. Verify cold fill pressure is correct and that operating pressure does not go too high.

Check burner flame

1. Inspect flame through observation window.
2. If the flame is unsatisfactory at either high fire or low fire, turn off boiler and allow boiler to cool down. Remove the burner and clean it thoroughly using a vacuum cleaner or compressed air. Do not use compressed air to clean burner if performed inside a building.
3. Remove the burner, reference FIG.'s 12-2 thru 12-4.
4. When replacing the burner, ensure gasket is in good condition and positioned correctly (FIG.'s 12-2 thru 12-4).

Figure 12-2 Burner Assembly - Model 399

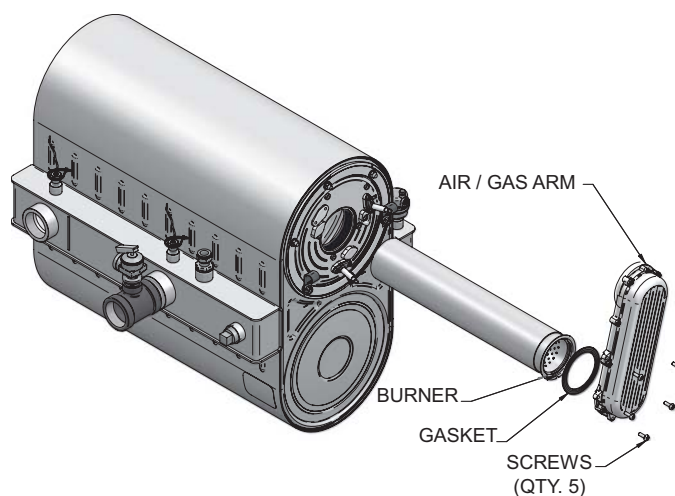
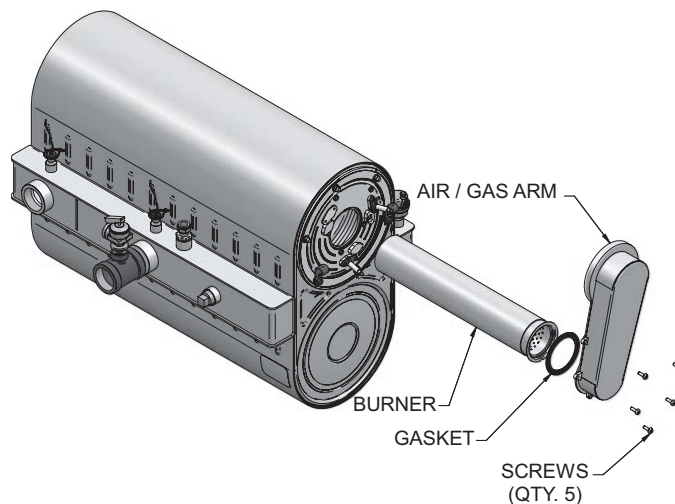
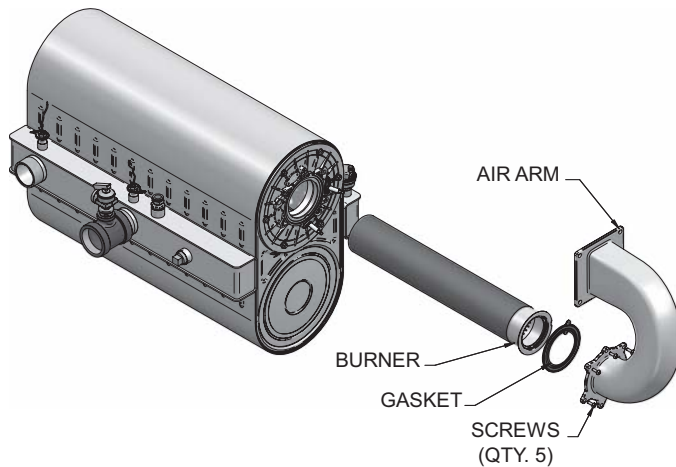

Figure 12-3 Burner Assembly - Model 500



12 Maintenance *(continued)*

Figure 12-4 Burner Assembly - Models 600 - 800



Check flame signal

1. At high fire the flame signal shown on the display should be at least 10 microamps.
2. A lower flame signal may indicate a fouled or damaged flame sense electrode. If cleaning the flame sense electrode does not improve, ground wiring is in good condition, and ground continuity is satisfactory, replace the flame sense electrode.
3. See Section 3 - Troubleshooting in the Knight XL Service Manual for other procedures to deal with low flame signal.

Review with owner

1. Review the Knight XL User's Information Manual with the owner.
2. Emphasize the need to perform the maintenance schedule specified in the Knight XL User's Information Manual (and in this manual as well).
3. Remind the owner of the need to call a licensed contractor should the boiler or system exhibit any unusual behavior.
4. Remind the owner to follow the proper shutdown procedure and to schedule an annual start-up at the beginning of the next heating season.

Cleaning boiler heat exchanger

1. Shut down boiler:
 - Follow the "To Turn Off Gas to Appliance" instructions for the boiler in Section 10 - Startup.
 - Do not drain the boiler unless it will be exposed to freezing temperatures. If using freeze prevention fluid in system, do not drain.
2. Allow time for the boiler to cool to room temperature if it has been firing.
3. Remove the blower assembly (gas air/arm) from the heat exchanger access cover. Set bolts aside.
4. Remove the nuts securing the heat exchanger access cover to the heat exchanger and set aside.
5. Remove the heat exchanger access cover, cover gasket(s) and chamber insulation assembly.

⚠ WARNING

The boiler contains ceramic fiber materials. Use care when handling these materials per instructions in the Handling Ceramic Fibers Section of the Knight XL Service Manual. Failure to comply could result in severe personal injury.

6. Use a vacuum cleaner to remove any accumulation on the boiler heating surfaces. Do not use any solvent.
7. Finish cleaning using a clean cloth dampened with warm water.
8. Install access cover gasket, chamber insulation assembly and cover.
9. Secure nuts on the studs. **DO NOT** overtighten.
10. Re-install the blower assembly (gas air/arm) using the bolts set aside in Step 3.
11. Close isolation valves on piping to isolate boiler from system. Attach a hose to the boiler drain and flush boiler thoroughly with clean water by using purging valves to allow water to flow through the water make-up line to the boiler.
12. When the boiler has been flushed, restore boiler to operation.
13. Perform start-up and check-out procedures in Section 10 - Startup.

13 Diagrams

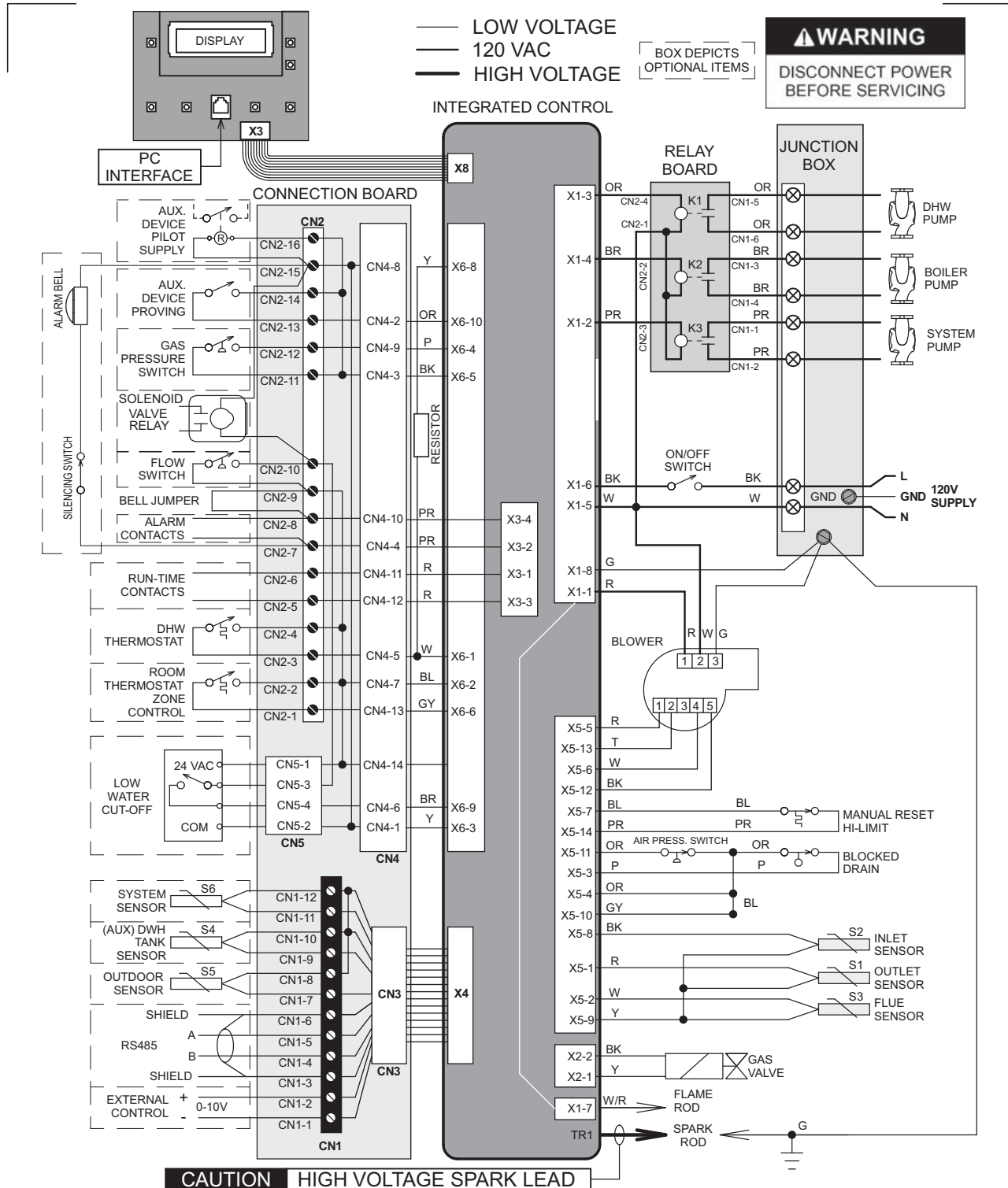
Figure 13-1 Wiring Diagram

13 Diagrams *(continued)*

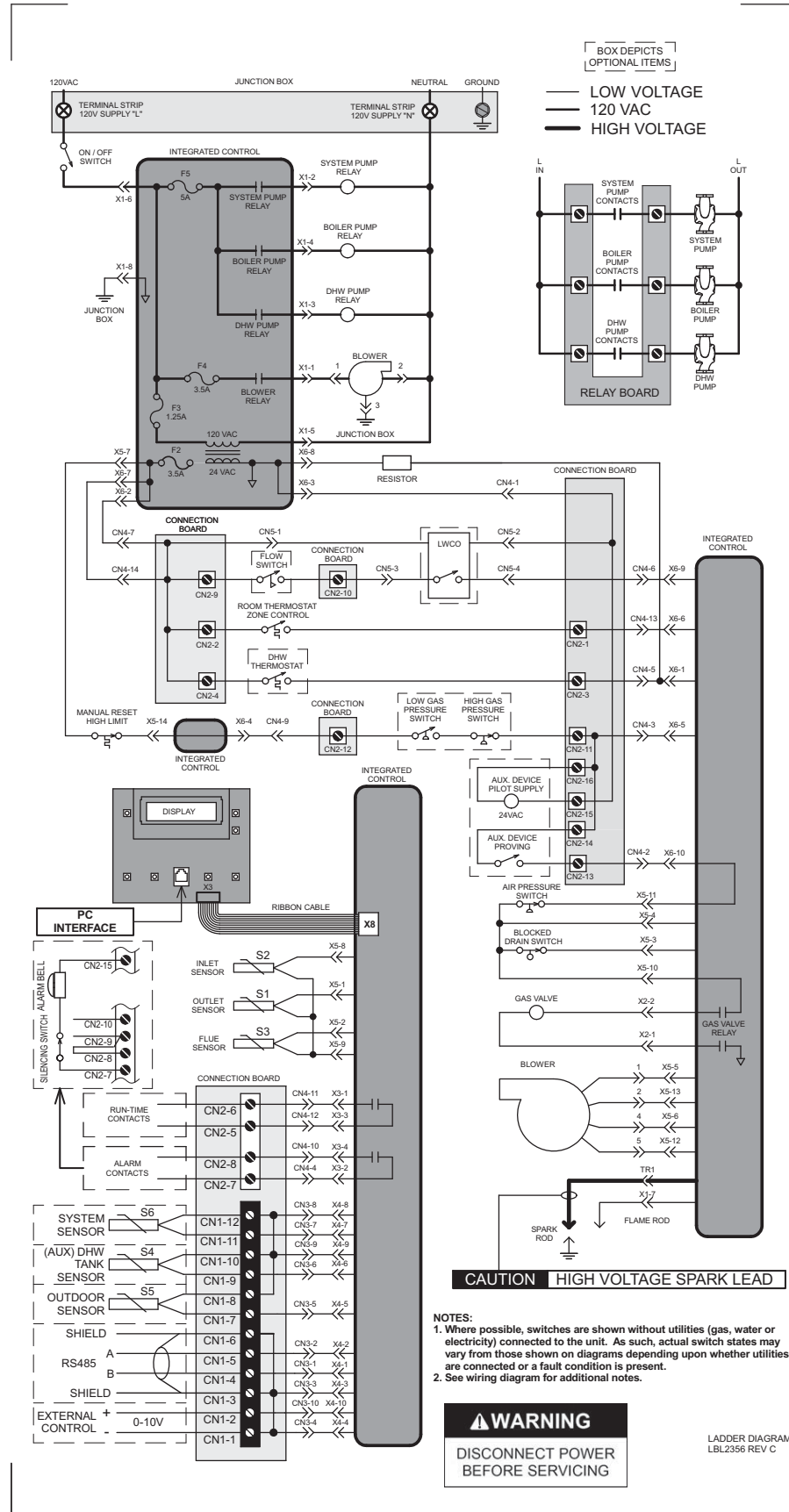
Figure 13-2 Ladder Diagram

Revision Notes: Revision B (ECO #C02407) reflects gas valve adjustment, room air, new sidewall vent termination, piping diagrams, flow switch, relief valve, T & P gauge, Maintenance Section, FIG. 8-1 (Line Voltage), and high altitude changes.

Revision C (ECO #C02545) reflects the addition of references to the safety shutoff testing and instructions, sediment trap, periodic cleaning of screens in vent terminations, removal of B149.2 references, changed the arrow direction on FIG. 6-8, wall thickness for direct vent terminations and sidewall vent termination kit number correction.

Revision D (ECO #C02738) reflects updates made to the line voltage image (FIG. 8-1 on page 43), and edits made to the gas conversion section for the new orifice on the 399 model (page 12).