

TECHNICAL & SERVICE MANUAL

OUTDOOR UNIT : CM1972
CM2472
CM3172

SANYO

FILE NO.

Destination: North America

DC INVERTER MULTI-SYSTEM AIR CONDITIONER

Capacity at 230V	Outdoor Model No.	Product Code No.
19,700 BTU/h	CM1972	1 852 330 27
25,400 BTU/h	CM2472	1 852 330 28
30,600 BTU/h	CM3172	1 852 330 29

CM1972

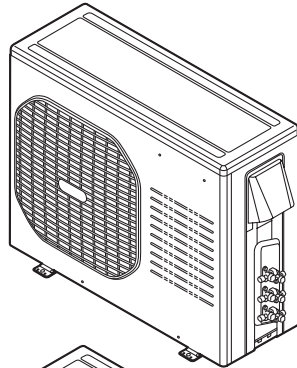

CM2472

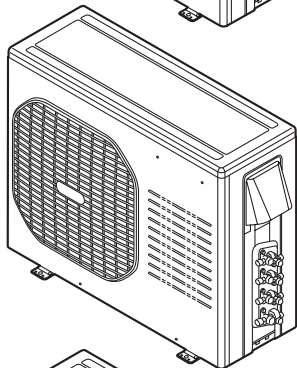

CM3172

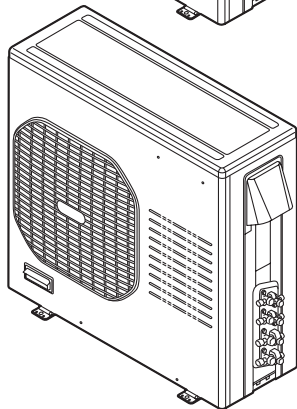

< Applicable Indoor Units >

- Wall mounted type
 - KMS0772
 - KMS0972
 - KMS1272
 - KMS1872
 - KMS2472

NOTE

For details about the combination, refer to "Unit Combination Table" in the Appendix of this manual.

IMPORTANT

These air conditioners employ new refrigerant R410A.

Pay special attention when servicing the unit.

R410A

Important! Please Read Before Starting

This air conditioning system meets strict safety and operating standards. As the installer or service person, it is an important part of your job to install or service the system so it operates safely and efficiently.

For safe installation and trouble-free operation, you must:

- Carefully read this instruction booklet before beginning.
- Follow each installation or repair step exactly as shown.
- Observe all local, state, and national electrical codes.
- Pay close attention to all warning and caution notices given in this manual.



WARNING

This symbol refers to a hazard or unsafe practice which can result in severe personal injury or death.



CAUTION

This symbol refers to a hazard or unsafe practice which can result in personal injury or product or property damage.

If Necessary, Get Help

These instructions are all you need for most installation sites and maintenance conditions. If you require help for a special problem, contact our sales/service outlet or your certified dealer for additional instructions.

In Case of Improper Installation

The manufacturer shall in no way be responsible for improper installation or maintenance service, including failure to follow the instructions in this document.

SPECIAL PRECAUTIONS

WARNING When Wiring



ELECTRICAL SHOCK CAN CAUSE SEVERE PERSONAL INJURY OR DEATH. ONLY A QUALIFIED, EXPERIENCED ELECTRICIAN SHOULD ATTEMPT TO WIRE THIS SYSTEM.

- Do not supply power to the unit until all wiring and tubing are completed or reconnected and checked.
- Highly dangerous electrical voltages are used in this system. Carefully refer to the wiring diagram and these instructions when wiring. Improper connections and inadequate grounding can cause accidental injury or death.
- Ground the unit following local electrical codes.
- Connect all wiring tightly. Loose wiring may cause overheating at connection points and a possible fire hazard.
- Install a protective leakage breaker depending on the installation location (especially a damp or humid location). If a leakage breaker is not installed, electric shock can occur.

When Transporting

Be careful when picking up and moving the indoor and outdoor units. Get a partner to help, and bend your knees when lifting to reduce strain on your back. Sharp edges or thin aluminum fins on the air conditioner can cut your fingers.

When Installing

In a Ceiling or Wall

Make sure the ceiling/wall is strong enough to hold the unit's weight. It may be necessary to construct a strong wood or metal frame to provide added support.

In a Room

Properly insulate any tubing run inside a room to prevent "sweating" that can cause dripping and water damage to walls and floors.

In Moist or Uneven Locations

Use a raised concrete pad or concrete blocks to provide a solid, level foundation for the outdoor unit. This prevents water damage and abnormal vibration.

In an Area with High Winds

Securely anchor the outdoor unit down with bolts and a metal frame. Provide a suitable air baffle.

In a Snowy Area (for Heat Pump-type Systems)

Install the outdoor unit on a raised platform that is higher than drifting snow. Provide snow vents.

When Connecting Refrigerant Tubing

- Use the flare method for connecting tubing.
- Apply refrigerant lubricant to the matching surfaces of the flare and union tubes before connecting them, then tighten the nut with a torque wrench for a leak-free connection.
- Check carefully for leaks before starting the test run.

When Servicing

- Turn the power off at the main power box (mains) before opening the unit to check or repair electrical parts and wiring.
- Keep your fingers and clothing away from any moving parts.
- Clean up the site after you finish, remembering to check that no metal scraps or bits of wiring have been left inside the unit being serviced.

Others



CAUTION

- Ventilate any enclosed areas when installing or testing the refrigeration system. Escaped refrigerant gas, on contact with fire or heat, can produce dangerously toxic gas.
- Confirm upon completing installation that no refrigerant gas is leaking. If escaped gas comes in contact with a stove, gas water heater, electric room heater or other heat source, it can produce dangerously toxic gas.

Table of Contents

	Page
■ APPLICABLE INDOOR UNITS	4
1. OPERATING RANGE	5
2. SPECIFICATIONS	
2-1. Unit Specifications	6
2-2. Major Component Specifications	12
2-3. Other Component Specifications	15
3. DIMENSIONAL DATA	16
4. REFRIGERANT FLOW DIAGRAM	
4-1. Refrigerant Flow Diagram	19
5. PERFORMANCE DATA	
5-1. Temperature Charts	22
5-2. Cooling Capacity	36
6. ELECTRICAL DATA	
6-1. Electric Wiring Diagrams	39
7. FUNCTIONS	
7-1. Explanation of Functions	42
7-2. Protective Functions	45
8. TROUBLESHOOTING	
8-1. Precautions before Performing Inspection or Repair	47
8-2. Trouble Diagnosis by Error Monitor Lamps.....	48
8-3. Checking the Outdoor System	49
8-4. Trouble Diagnosis of Each Part	50
8-5. Trouble Diagnosis of Fan Motor.....	54
9. REFRIGERANT R410A:	
SPECIAL PRECAUTIONS WHEN SERVICING UNIT	
9-1. Characteristics of New Refrigerant R410A	55
9-2. Checklist before Servicing	56
9-3. Tools Specifically for R410A	57
9-4. Tubing Installation Procedures	57
9-5. In Case of Compressor Malfunction	58
9-6. In Case Refrigerant is Leaking	60
9-7. Charging Additional Refrigerant	61
9-8. Retro-Fitting Existing Systems	61
APPENDIX A INSTALLATION INSTRUCTIONS	A-1
APPENDIX B UNIT COMBINATION TABLES	A-2

■ APPLICABLE INDOOR UNITS

Multi-Outdoor Unit \ Indoor Unit		KMS0772	KMS0972	KMS1272	KMS1872	KMS2472
		3-Room	CM1972	YES	YES	YES
4-Room	CM2472	YES	YES	YES	YES	YES
4-Room	CM3172	YES	YES	YES	YES	YES

NOTE The table lists the wall-mounted type of indoor units as representative models.

1. OPERATING RANGE

	Temperature	Indoor Air Intake Temp.	Outdoor Air Intake Temp.
Cooling	Maximum	95 °F D.B. / 71 °F W.B.	115 °F D.B.
	Minimum	67 °F D.B. / 57 °F W.B.	67 °F D.B.

2. SPECIFICATIONS

2-1. Unit Specifications

Outdoor Unit **CM1972**

Indoor Unit **KMS0972 × 3**

< 230V >

Type		3-Room Multi Outdoor Unit	
Number of Connectable Indoor Units		3	
Number of Operatable Indoor Units		3	
Voltage Rating		230V Single-Phase 60Hz	
		Cooling	
Performance	Total Capacity	BTU/h	19,700 (9,800 to 19,700)
		kW	5.80 (2.90 to 5.80)
	Sensible Capacity	BTU/h	16,800
	Latent Capacity	BTU/h	2,900
	Air Circulation (High)	ft ³ /min (m ³ /h)	1,707 (2,900)
Electrical Rating	Available Voltage Range		V 187 to 253
	Running Amperes		A 7.0
	Power Input		W 1,570
	Power Factor		% 98
	EER		BTU/h/W 12.5
	SEER		BTU/Wh 16.5
	Compressor Locked Rotor Amperes		A 13.0
	Fuse or Circuit Breaker Capacity		A 20
			Outdoor Unit
Features	Control		Microprocessor
	Fan Speeds		Auto (Hi, Me, Lo)
	Compressor		DC Twin Rotary (Inverter)
	Refrigerant / Amount charged at shipment		lbs (g) R410A / 6.17 (2,800)
	Refrigerant Control		Electric Expansion Valve
	Operation Sound (High) Cool		dB-A 50
	Refrigerant Tubing Connections		Flare Type
	Max. allowable tubing length per unit		ft (m) 82 (25)
	Refrigerant		Narrow tube inch (mm) 1/4 (6.35) × 3
	Tube Diameter		Wide tube inch (mm) 3/8 (9.52) × 3
		Outdoor Unit	
Dimensions & Weight	Unit Dimensions		inch 29-1/8 × 35-7/16 × 12-19/32
	Height × Width × Depth		(mm) (740 × 900 × 320)
	Package Dimensions		inch 33-27/32 × 40-5/8 × 16-1/4
	Height × Width × Depth		(mm) (860 × 1,032 × 413)
	Weight		Net lbs (kg) 138.9 (63.0)
	Shipping		lbs (kg) 147.7 (67.0)
Shipping Volume		cu.ft (m ³) 12.71 (0.36)	

DATA SUBJECT TO CHANGE WITHOUT NOTICE.

Remarks:

- The values shown in performance section and electrical rating section above are based on the following unit combination.
For other combination unit, please refer to the "Unit Combination Tables" in this manual.
Indoor Unit : KMS0972 3units Outdoor Unit : CM1972 1unit
- Rating conditions are: Cooling : Indoor air temp. 80°F D.B./ 67°F W.B.
Outdoor air temp. 95°F D.B./ 75°F W.B.

Outdoor Unit **CM1972**
Indoor Unit **KMS0972 × 3**

< 208V >

Type		3-Room Multi Outdoor Unit			
Number of Connectable Indoor Units		3			
Number of Operatable Indoor Units		3			
Voltage Rating		208V Single-Phase 60Hz			
		Cooling			
Performance	Total Capacity	BTU/h	19,700 (9,800 to 19,700)		
		kW	5.80 (2.90 to 5.80)		
	Sensible Capacity	BTU/h	16,800		
	Latent Capacity	BTU/h	2,900		
	Air Circulation (High)	ft ³ /min (m ³ /h)	1,707 (2,900)		
Electrical Rating	Available Voltage Range		V	187 to 253	
	Running Amperes		A	7.7	
	Power Input		W	1,570	
	Power Factor		%	98	
	EER		BTU/h/W	12.5	
	SEER		BTU/Wh	16.5	
	Compressor Locked Rotor Amperes		A	13.0	
	Fuse or Circuit Breaker Capacity		A	20	
			Outdoor Unit		
Features	Control		Microprocessor		
	Fan Speeds		Auto (Hi, Me, Lo)		
	Compressor		DC Twin Rotary (Inverter)		
	Refrigerant / Amount charged at shipment		lbs (g)	R410A / 6.17 (2,800)	
	Refrigerant Control		Electric Expansion Valve		
	Operation Sound (High) Cool		dB-A	50	
	Refrigerant Tubing Connections		Flare Type		
	Max. allowable tubing length per unit		ft (m)	82 (25)	
	Refrigerant		Narrow tube	inch (mm)	1/4 (6.35) × 3
	Tube Diameter		Wide tube	inch (mm)	3/8 (9.52) × 3
		Outdoor Unit			
Dimensions & Weight	Unit Dimensions		inch	29-1/8 × 35-7/16 × 12-19/32	
	Height × Width × Depth		(mm)	(740 × 900 × 320)	
	Package Dimensions		inch	33-27/32 × 40-5/8 × 16-1/4	
	Height × Width × Depth		(mm)	(860 × 1,032 × 413)	
	Weight		Net	lbs (kg)	138.9 (63.0)
			Shipping	lbs (kg)	147.7 (67.0)
Shipping Volume		cu.ft (m ³)	12.71 (0.36)		

DATA SUBJECT TO CHANGE WITHOUT NOTICE.

Remarks:

- The values shown in performance section and electrical rating section above are based on the following unit combination.
For other combination unit, please refer to the "Unit Combination Tables" in this manual.
Indoor Unit : KMS0972 3units Outdoor Unit : CM1972 1unit
- Rating conditions are: Cooling : Indoor air temp. 80°F D.B./ 67°F W.B.
Outdoor air temp. 95°F D.B./ 75°F W.B.

Outdoor Unit **CM2472**
 Indoor Unit **KMS0972 × 3**

< 230V >

Type		4-Room Multi Outdoor Unit	
Number of Connectable Indoor Units		4	
Number of Operatable Indoor Units		3	
Voltage Rating		230V Single-Phase 60Hz	
		Cooling	
Performance	Total Capacity	BTU/h	25,400 (9,800 to 25,400)
		kW	7.50 (2.90 to 7.50)
	Sensible Capacity	BTU/h	21,400
	Latent Capacity	BTU/h	4,000
	Air Circulation (High)	ft ³ /min (m ³ /h)	1,707 (2,900)
Electrical Rating	Available Voltage Range		V 187 to 253
	Running Amperes		A 11.3
	Power Input		W 2,560
	Power Factor		% 98
	EER		BTU/h/W 9.9
	SEER		BTU/Wh 16.2
	Compressor Locked Rotor Amperes		A 13.0
	Fuse or Circuit Breaker Capacity		A 20
			Outdoor Unit
Features	Control		Microprocessor
	Fan Speeds		Auto (Hi, Me, Lo)
	Compressor		DC Twin Rotary (Inverter)
	Refrigerant / Amount charged at shipment		lbs (g) R410A / 6.17 (2,800)
	Refrigerant Control		Electric Expansion Valve
	Operation Sound (High) Cool		dB-A 50
	Refrigerant Tubing Connections		Flare Type
	Max. allowable tubing length per unit		ft (m) 82 (25)
	Refrigerant		Narrow tube inch (mm) 1/4 (6.35) × 4
	Tube Diameter		Wide tube inch (mm) 3/8 (9.52) × 3 + 1/2 (12.7) × 1
		Outdoor Unit	
Dimensions & Weight	Unit Dimensions		inch 29-1/8 × 35-7/16 × 12-19/32
	Height × Width × Depth		(mm) (740 × 900 × 320)
	Package Dimensions		inch 33-27/32 × 40-5/8 × 16-1/4
	Height × Width × Depth		(mm) (860 × 1,032 × 413)
	Weight		Net lbs (kg) 138.9 (63.0)
	Shipping		lbs (kg) 147.7 (67.0)
Shipping Volume		cu.ft (m ³) 12.71 (0.36)	

DATA SUBJECT TO CHANGE WITHOUT NOTICE.

Remarks:

- The values shown in performance section and electrical rating section above are based on the following unit combination.
 For other combination unit, please refer to the "Unit Combination Tables" in this manual.
 Indoor Unit : KMS0972 3units Outdoor Unit : CM2472 1unit
- Rating conditions are: Cooling : Indoor air temp. 80°F D.B./ 67°F W.B.
 Outdoor air temp. 95°F D.B./ 75°F W.B.

Outdoor Unit **CM2472**
 Indoor Unit **KMS0972 × 3**

< 208V >

Type		4-Room Multi Outdoor Unit		
Number of Connectable Indoor Units		4		
Number of Operatable Indoor Units		3		
Voltage Rating		208V Single-Phase 60Hz		
		Cooling		
Performance	Total Capacity	BTU/h	24,400 (9,800 to 24,400)	
		kW	7.20 (2.90 to 7.20)	
	Sensible Capacity	BTU/h	20,600	
	Latent Capacity	BTU/h	3,800	
	Air Circulation (High)	ft ³ /min (m ³ /h)	1,707 (2,900)	
Electrical Rating	Available Voltage Range	V	187 to 253	
	Running Amperes	A	12.5	
	Power Input	W	2,560	
	Power Factor	%	98	
	EER	BTU/h/W	9.5	
	SEER	BTU/Wh	16.2	
	Compressor Locked Rotor Amperes	A	13.0	
	Fuse or Circuit Breaker Capacity	A	20	
		Outdoor Unit		
Features	Control		Microprocessor	
	Fan Speeds		Auto (Hi, Me, Lo)	
	Compressor		DC Twin Rotary (Inverter)	
	Refrigerant / Amount charged at shipment	lbs (g)	R410A / 6.17 (2,800)	
	Refrigerant Control		Electric Expansion Valve	
	Operation Sound (High) Cool	dB-A	50	
	Refrigerant Tubing Connections		Flare Type	
	Max. allowable tubing length per unit	ft (m)	82 (25)	
	Refrigerant	Narrow tube inch (mm)	1/4 (6.35) × 4	
	Tube Diameter	Wide tube inch (mm)	3/8 (9.52) × 3 + 1/2 (12.7) × 1	
		Outdoor Unit		
Dimensions & Weight	Unit Dimensions		29-1/8 × 35-7/16 × 12-19/32	
	Height × Width × Depth	inch (mm)	(740 × 900 × 320)	
	Package Dimensions		33-27/32 × 40-5/8 × 16-1/4	
	Height × Width × Depth	inch (mm)	(860 × 1,032 × 413)	
	Weight	Net	lbs (kg)	138.9 (63.0)
		Shipping	lbs (kg)	147.7 (67.0)
Shipping Volume		cu.ft (m ³)	12.71 (0.36)	

DATA SUBJECT TO CHANGE WITHOUT NOTICE.

Remarks:

- The values shown in performance section and electrical rating section above are based on the following unit combination.
 For other combination unit, please refer to the "Unit Combination Tables" in this manual.
 Indoor Unit : KMS0972 3units Outdoor Unit : CM2472 1unit
- Rating conditions are: Cooling : Indoor air temp. 80°F D.B./ 67°F W.B.
 Outdoor air temp. 95°F D.B./ 75°F W.B.

Outdoor Unit **CM3172**
 Indoor Unit **KMS0972 × 4**

< 230V >

Type		4-Room Multi Outdoor Unit	
Number of Connectable Indoor Units		4	
Number of Operatable Indoor Units		4	
Voltage Rating		230V Single-Phase 60Hz	
		Cooling	
Performance	Total Capacity	BTU/h	30,600 (9,800 to 30,600)
		kW	9.00 (2.90 to 9.00)
	Sensible Capacity	BTU/h	25,800
	Latent Capacity	BTU/h	4,800
	Air Circulation (High)	ft ³ /min (m ³ /h)	1,942 (3,300)
Electrical Rating	Available Voltage Range	V	187 to 253
	Running Amperes	A	12.3
	Power Input	W	2,800
	Power Factor	%	99
	EER	BTU/h/W	10.9
	SEER	BTU/Wh	17.6
	Compressor Locked Rotor Amperes	A	17.0
	Fuse or Circuit Breaker Capacity	A	20
Features	Control		Microprocessor
	Fan Speeds		Auto (Hi, Me, Lo)
	Compressor		DC Twin Rotary (Inverter)
	Refrigerant / Amount charged at shipment	lbs (g)	R410A / 8.38 (3,800)
	Refrigerant Control		Electric Expansion Valve
	Operation Sound (High) Cool	dB-A	53
	Refrigerant Tubing Connections		Flare Type
	Max. allowable tubing length per unit	ft (m)	100 (30.5)
	Refrigerant	Narrow tube inch (mm)	1/4 (6.35) × 4
	Tube Diameter	Wide tube inch (mm)	3/8 (9.52) × 2 + 1/2 (12.7) × 2
			Outdoor Unit
Dimensions & Weight	Unit Dimensions	inch	35-1/32 × 35-7/16 × 12-19/32
	Height × Width × Depth	(mm)	(890 × 900 × 320)
	Package Dimensions	inch	39-3/4 × 40-5/8 × 16-1/4
	Height × Width × Depth	(mm)	(1,010 × 1,032 × 413)
	Weight	Net lbs (kg)	174.2 (79.0)
		Shipping lbs (kg)	183.0 (83.0)
	Shipping Volume	cu.ft (m ³)	15.18 (0.43)

DATA SUBJECT TO CHANGE WITHOUT NOTICE.

Remarks:

- The values shown in performance section and electrical rating section above are based on the following unit combination.
 For other combination unit, please refer to the "Unit Combination Tables" in this manual.
 Indoor Unit : KMS0972 4units Outdoor Unit : CM3172 1unit
- Rating conditions are: Cooling : Indoor air temp. 80°F D.B./ 67°F W.B.
 Outdoor air temp. 95°F D.B./ 75°F W.B.

Outdoor Unit **CM3172**
 Indoor Unit **KMS0972 × 4**

< 208V >

Type		4-Room Multi Outdoor Unit		
Number of Connectable Indoor Units		4		
Number of Operatable Indoor Units		4		
Voltage Rating		208V Single-Phase 60Hz		
		Cooling		
Performance	Total Capacity	BTU/h	28,600 (9,800 to 28,600)	
		kW	8.40 (2.90 to 8.40)	
	Sensible Capacity	BTU/h	24,200	
	Latent Capacity	BTU/h	4,400	
	Air Circulation (High)	ft ³ /min (m ³ /h)	1,942 (3,300)	
Electrical Rating	Available Voltage Range	V	187 to 253	
	Running Amperes	A	13.6	
	Power Input	W	2,800	
	Power Factor	%	99	
	EER	BTU/h/W	10.2	
	SEER	BTU/Wh	17.6	
	Compressor Locked Rotor Amperes	A	17.0	
	Fuse or Circuit Breaker Capacity	A	20	
			Outdoor Unit	
Features	Control		Microprocessor	
	Fan Speeds		Auto (Hi, Me, Lo)	
	Compressor		DC Twin Rotary (Inverter)	
	Refrigerant / Amount charged at shipment	lbs (g)	R410A / 8.38 (3,800)	
	Refrigerant Control		Electric Expansion Valve	
	Operation Sound (High) Cool	dB-A	53	
	Refrigerant Tubing Connections		Flare Type	
	Max. allowable tubing length per unit	ft (m)	100 (30.5)	
	Refrigerant	Narrow tube inch (mm)	1/4 (6.35) × 4	
	Tube Diameter	Wide tube inch (mm)	3/8 (9.52) × 2 + 1/2 (12.7) × 2	
		Outdoor Unit		
Dimensions & Weight	Unit Dimensions		35-1/32 × 35-7/16 × 12-19/32	
	Height × Width × Depth	inch (mm)	(890 × 900 × 320)	
	Package Dimensions		39-3/4 × 40-5/8 × 16-1/4	
	Height × Width × Depth	inch (mm)	(1,010 × 1,032 × 413)	
	Weight	Net	lbs (kg)	174.2 (79.0)
		Shipping	lbs (kg)	183.0 (83.0)
Shipping Volume		cu.ft (m ³)	15.18 (0.43)	

DATA SUBJECT TO CHANGE WITHOUT NOTICE.

Remarks:

- The values shown in performance section and electrical rating section above are based on the following unit combination.
 For other combination unit, please refer to the "Unit Combination Tables" in this manual.
 Indoor Unit : KMS0972 4units Outdoor Unit : CM3172 1unit
- Rating conditions are: Cooling : Indoor air temp. 80°F D.B./ 67°F W.B.
 Outdoor air temp. 95°F D.B./ 75°F W.B.

2-2. Major Component Specifications

2-2-1. Outdoor Unit

Outdoor Unit **CM1972**

Control PCB	
Part No.	CB-CM1972
Controls	Microprocessor
Control Circuit Fuse	250V 25A

Compressor	
Type	DC Twin Rotary (Hermetic)
Compressor Model / Nominal Output	5KD240XAB21 / 1,700W
Compressor Oil ... Amount	Pints (cc) FV50S ... 1.91 (900)
Coil Resistance (Ambient Temp. 68 °F (20 °C))	Ohm U - V : 0.720 V - W : 0.708 W - U : 0.726
Safety Device	
CT (Peak current cut-off control)	Yes
Compressor Discharge Temp. Control	Yes
Operation cut-off control in abnormal ambient Temp.	Yes
Overload Relay	Model CS-7LN115
	Operation Temp. Open : 239 °F (115 °C), Close : 212 °F (100 °C)
Run Capacitor	Micro F -
	VAC -
Crankcase Heater	-

Fan	
Type	Propeller
Q'ty ... Dia.	inch (mm) 1 ... D18-1/8 (D460)

Fan Motor	
Type	DC Motor
Model ... Q'ty	SIC-71FW-D490-1 ... 1
No. of Poles	8
Rough Measure RPM (Cool)	750
Nominal Output	W 90
Coil Resistance	Ohm -
(Ambient Temp. 68 °F (20 °C))	
Safety Device	
Type	Internal Controller
Over-Current Protection	Yes
Over-Heat Protection	Yes
Run Capacitor	Micro F -
	VAC -

Heat Exchanger Coil	
Coil	Aluminum Plate Fin / Copper Tube
Rows	2
Fins per inch	18.1
Face Area	ft ² (m ²) 6.40 (0.595)

External Finish	Acrylic baked-on enamel finish
------------------------	--------------------------------

DATA SUBJECT TO CHANGE WITHOUT NOTICE.

Outdoor Unit **CM2472**

Control PCB	
Part No.	CB-CM2572
Controls	Microprocessor
Control Circuit Fuse	250V 25A

Compressor	
Type	DC Twin Rotary (Hermetic)
Compressor Model / Nominal Output	5KD240XAB21 / 1,700W
Compressor Oil ... Amount	Pints (cc) FV50S ... 1.91 (900)
Coil Resistance (Ambient Temp. 68 °F (20 °C))	Ohm U - V : 0.720 V - W : 0.708 W - U : 0.726
Safety Device	
CT (Peak current cut-off control)	Yes
Compressor Discharge Temp. Control	Yes
Operation cut-off control in abnormal ambient Temp.	Yes
Overload Relay	Model CS-7LN115
	Operation Temp. Open : 239 °F (115 °C), Close : 212 °F (100 °C)
Run Capacitor	Micro F -
	VAC -
Crankcase Heater	-

Fan	
Type	Propeller
Q'ty ... Dia.	inch (mm) 1 ... D18-1/8 (D460)

Fan Motor	
Type	DC Motor
Model ... Q'ty	SIC-71FW-D490-1 ... 1
No. of Poles	8
Rough Measure RPM (Cool)	750
Nominal Output	W 90
Coil Resistance	Ohm -
(Ambient Temp. 68 °F (20 °C))	
Safety Device	
Type	Internal Controller
Over-Current Protection	Yes
Over-Heat Protection	Yes
Run Capacitor	Micro F -
	VAC -

Heat Exchanger Coil	
Coil	Aluminum Plate Fin / Copper Tube
Rows	2
Fins per inch	18.1
Face Area	ft ² (m ²) 6.40 (0.595)

External Finish	Acrylic baked-on enamel finish
------------------------	--------------------------------

DATA SUBJECT TO CHANGE WITHOUT NOTICE.

Outdoor Unit **CM3172**

Control PCB	
Part No.	CB-CM3172
Controls	Microprocessor
Control Circuit Fuse	250V 25A

Compressor	
Type	DC Twin Rotary (Hermetic)
Compressor Model / Nominal Output	5JD420XAB22 / 3,000W
Compressor Oil ... Amount	Pints (cc) FV50S ... 2.55 (1,200)
Coil Resistance (Ambient Temp. 68 °F (20 °C))	Ohm U - V : 0.435 V - W : 0.441 W - U : 0.452
Safety Device	
CT (Peak current cut-off control)	Yes
Compressor Discharge Temp. Control	Yes
Operation cut-off control in abnormal ambient Temp.	Yes
Overload Relay	Model CS-7LN115
	Operation Temp. Open : 239 °F (115 °C), Close : 212 °F (100 °C)
Run Capacitor	Micro F -
	VAC -
Crankcase Heater	-

Fan	
Type	Propeller
Q'ty ... Dia.	inch (mm) 1 ... D18-1/8 (D460)

Fan Motor	
Type	DC Motor
Model ... Q'ty	SIC-71FW-D490-1 ... 1
No. of Poles	8
Rough Measure RPM (Cool)	800
Nominal Output	W 90
Coil Resistance	Ohm (Ambient Temp. 68 °F (20 °C)) -
Safety Device	
Type	Internal Controller
Over-Current Protection	Yes
Over-Heat Protection	Yes
Run Capacitor	Micro F -
	VAC -

Heat Exchanger Coil	
Coil	Aluminum Plate Fin / Copper Tube
Rows	2
Fins per inch	18.1
Face Area	ft ² (m ²) 7.75 (0.72)

External Finish	Acrylic baked-on enamel finish
------------------------	--------------------------------

DATA SUBJECT TO CHANGE WITHOUT NOTICE.

2-3. Other Component Specifications

Sensor Name	Model No. of sensor	Quantity of Sensor		
		CM1972	CM2472	CM3172
Outdoor air temp sensor	TKS295B	1	1	1
Outdoor heat exchanger sensor	TKS292B	1	1	1
AW / AN sensor	TKS292B	1 / 1	1 / 1	1 / 1
BW / BN sensor	TKS292B	1 / 1	1 / 1	1 / 1
CW / CN sensor	TKS292B	1 / 1	1 / 1	1 / 1
DW / DN sensor	TKS292B	0	1 / 1	1 / 1

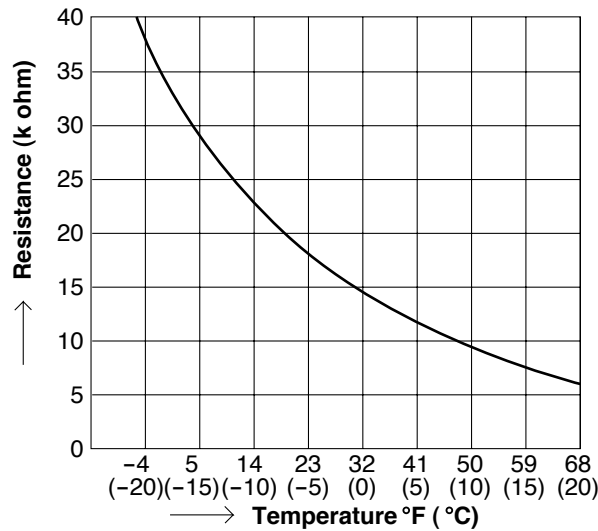

Sensor Name	Model No. of sensor	Quantity of Sensor		
		CM1972	CM2472	CM3172
Compressor temp sensor	TKS293B	1	1	1

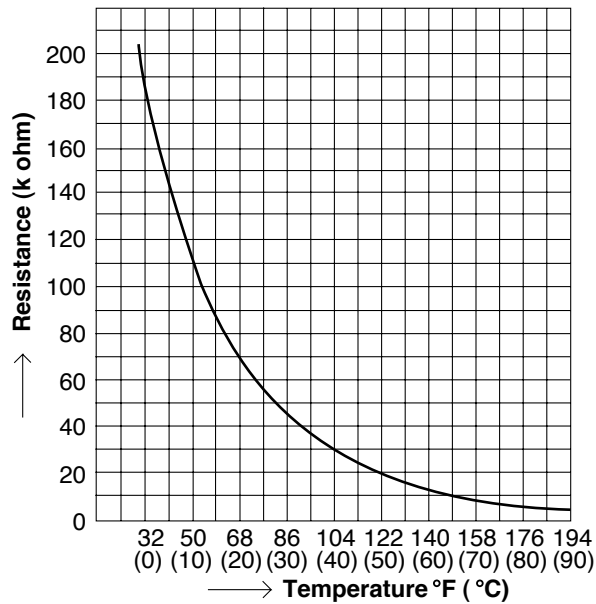

3. DIMENSIONAL DATA

Outdoor Unit CM1972

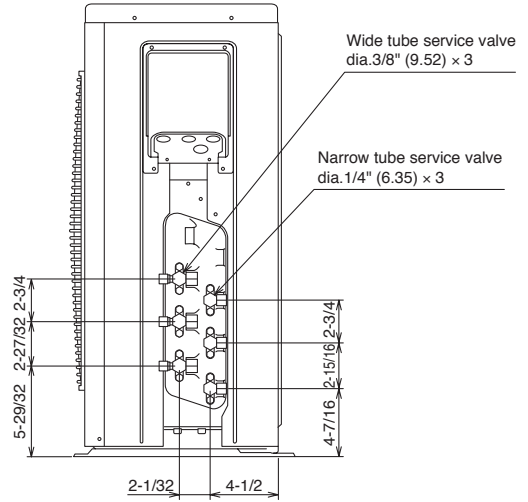
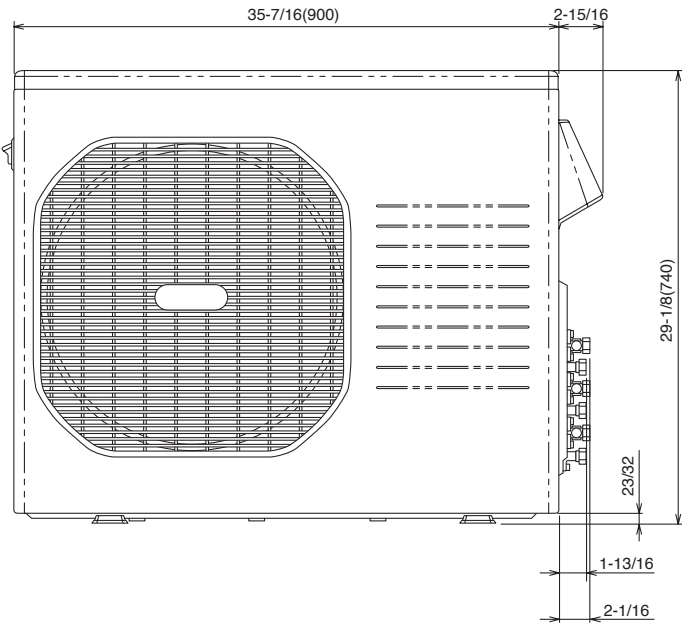
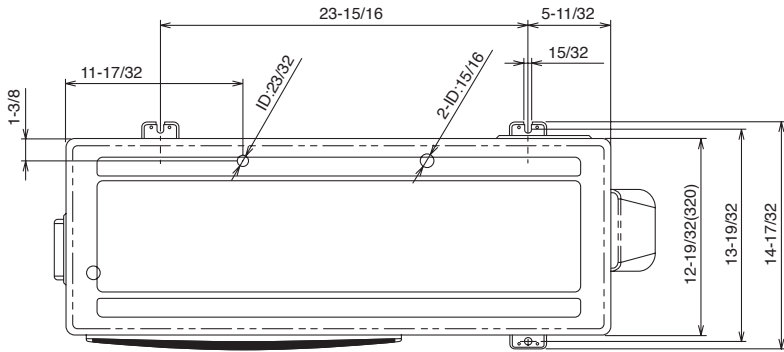

Unit: inch(mm)

Outdoor Unit **CM2472**

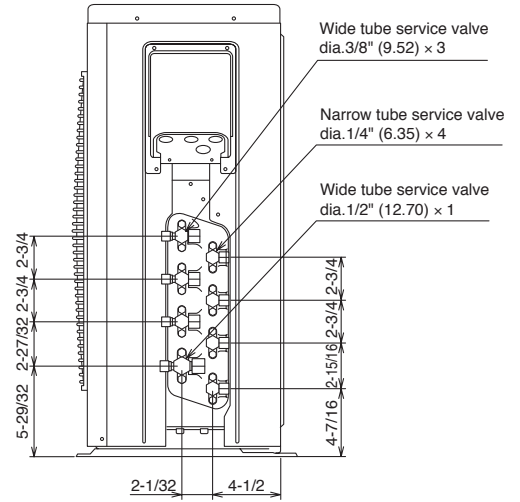
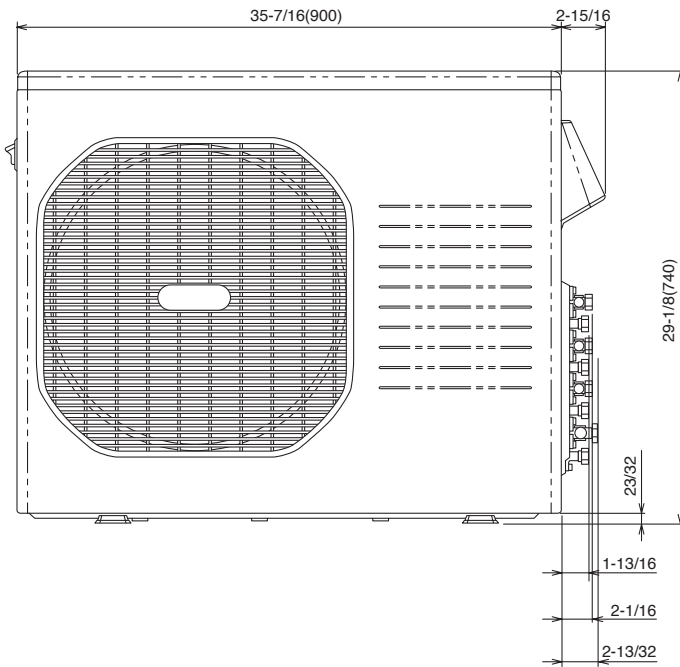
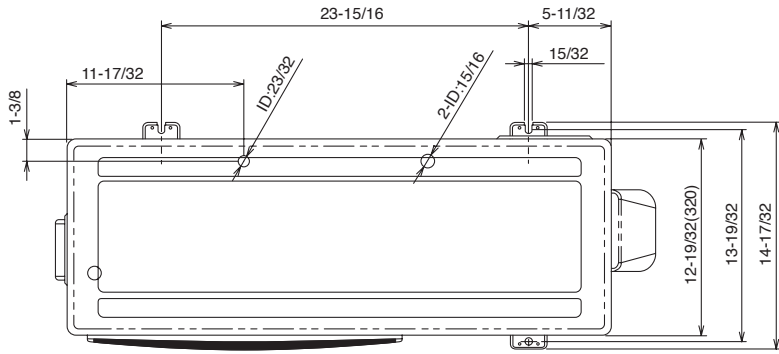

Unit: inch(mm)

Outdoor Unit **CM3172**

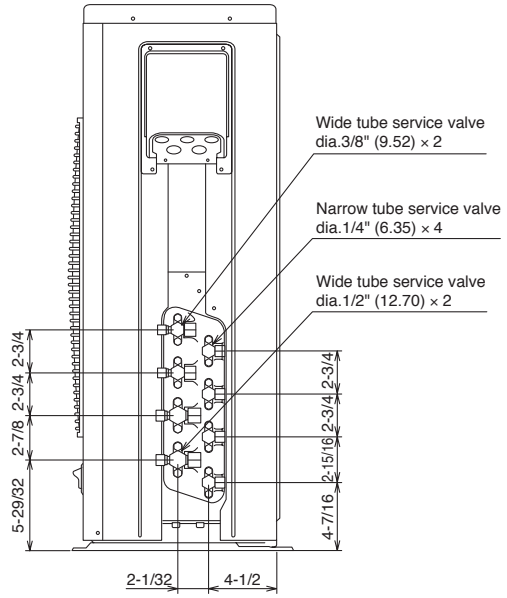
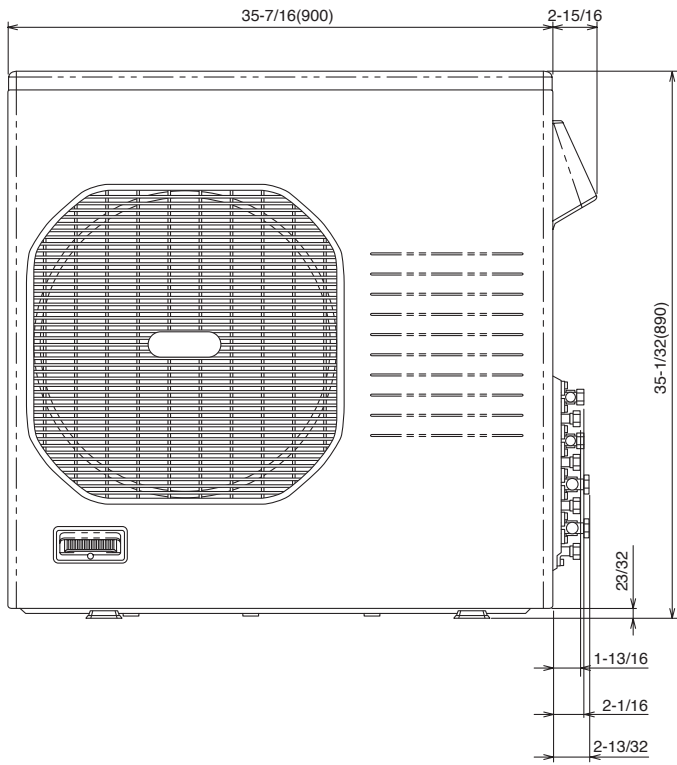
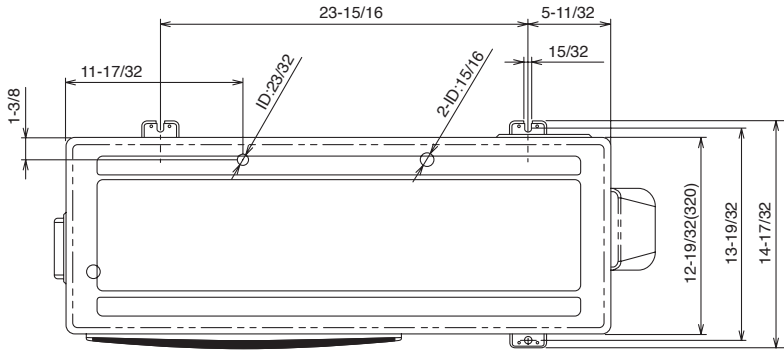

Unit: inch(mm)

4. REFRIGERANT FLOW DIAGRAM

4-1. Refrigerant Flow Diagram

Outdoor Unit CM1972

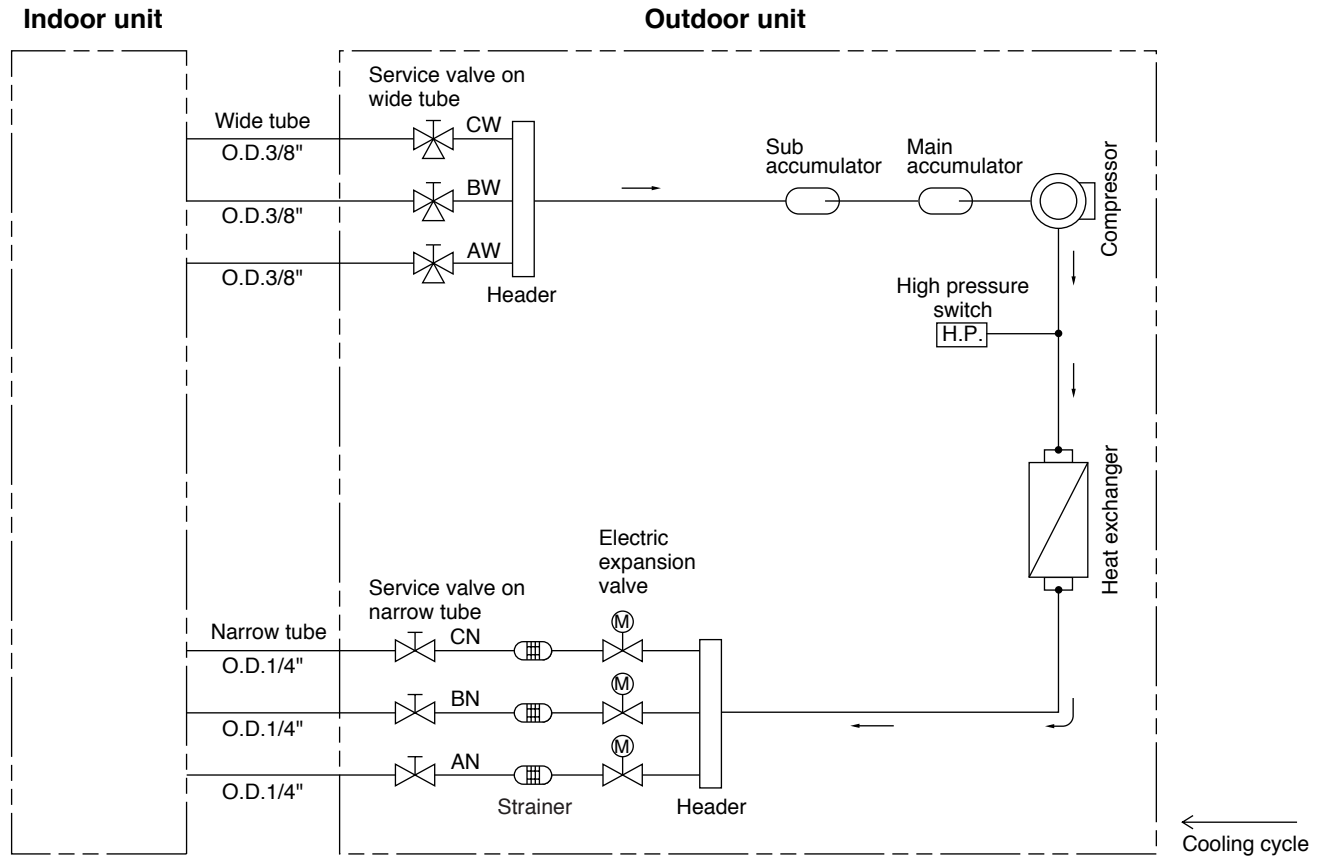

Insulation of Refrigerant Tubing

IMPORTANT

Because capillary tubing is used in the outdoor unit, both the wide and narrow tubes of this air conditioner become cold. To prevent heat loss and wet floors due to dripping of condensation, **both tubes must be well insulated** with a proper insulation material. The thickness of the insulation should be a min.5/16"(8 mm).

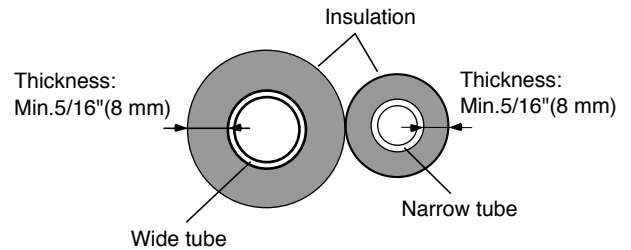

CAUTION

After a tube has been insulated, never try to bend it into a narrow curve because it can cause the tube to break or crack.

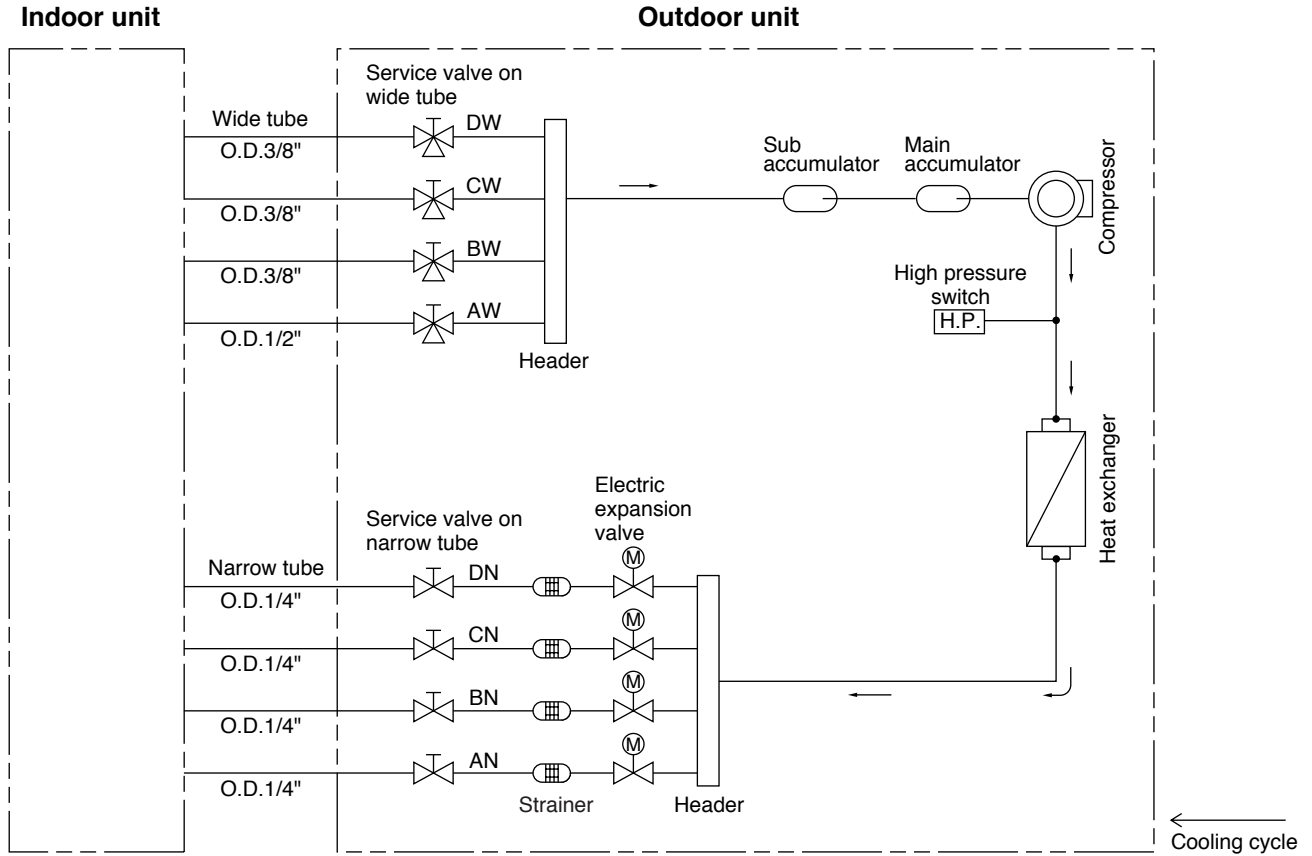

Insulation of Refrigerant Tubing

IMPORTANT

Because capillary tubing is used in the outdoor unit, both the wide and narrow tubes of this air conditioner become cold. To prevent heat loss and wet floors due to dripping of condensation, **both tubes must be well insulated** with a proper insulation material. The thickness of the insulation should be a min.5/16"(8 mm).

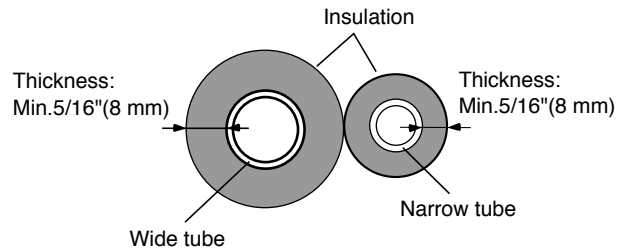

CAUTION

After a tube has been insulated, never try to bend it into a narrow curve because it can cause the tube to break or crack.

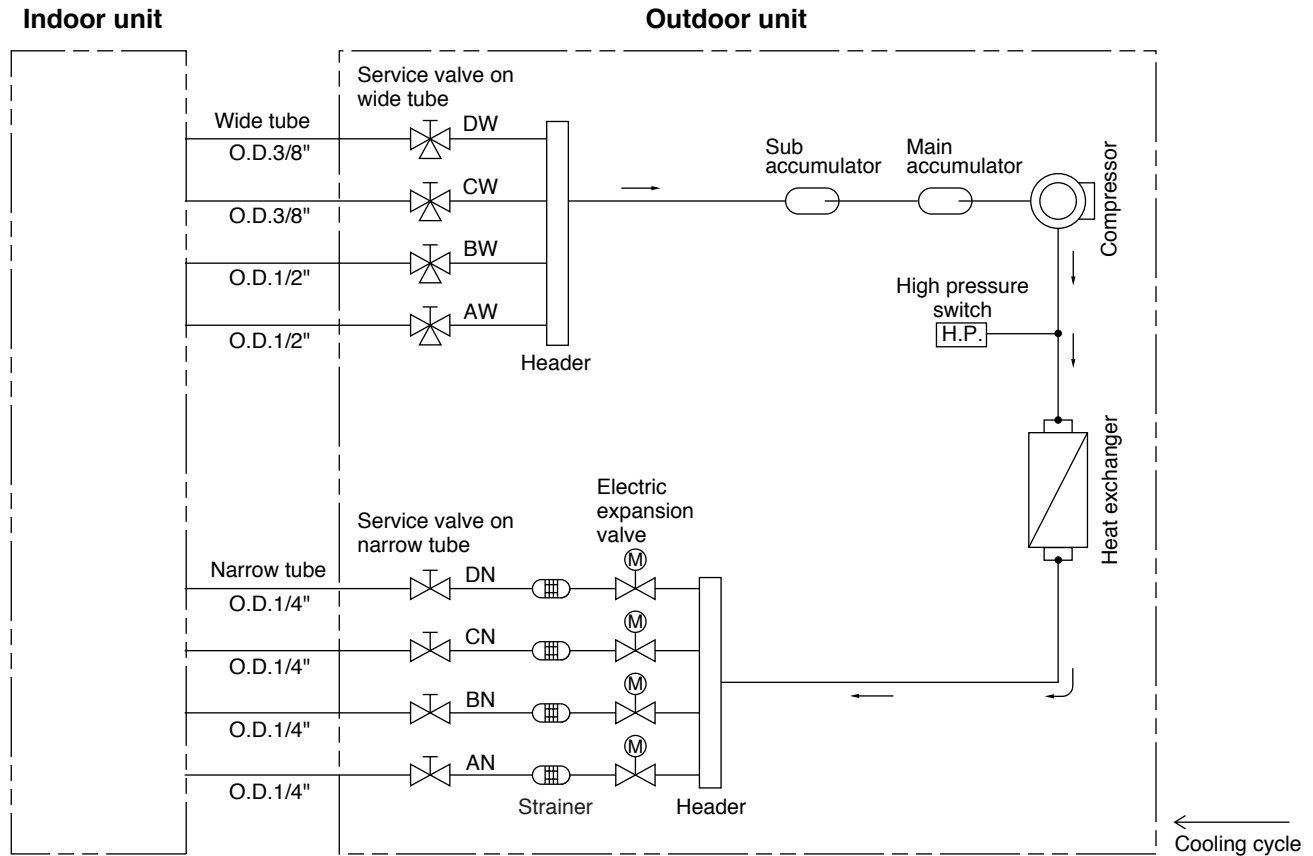

Insulation of Refrigerant Tubing

IMPORTANT

Because capillary tubing is used in the outdoor unit, both the wide and narrow tubes of this air conditioner become cold. To prevent heat loss and wet floors due to dripping of condensation, **both tubes must be well insulated** with a proper insulation material. The thickness of the insulation should be a min.5/16"(8 mm).

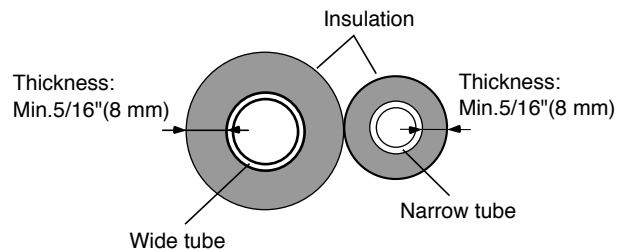

CAUTION

After a tube has been insulated, never try to bend it into a narrow curve because it can cause the tube to break or crack.

5. PERFORMANCE DATA

5-1. Temperature Charts

5-1-1. Temperature Charts (CM1972)

Outdoor Unit **CM1972** Indoor Unit **KMS0772** × 1

■ Cooling Characteristics
 (RH : 46%, Indoor fan speed : High fan)
 (230V, 60Hz)

(1) Low pressure performance chart

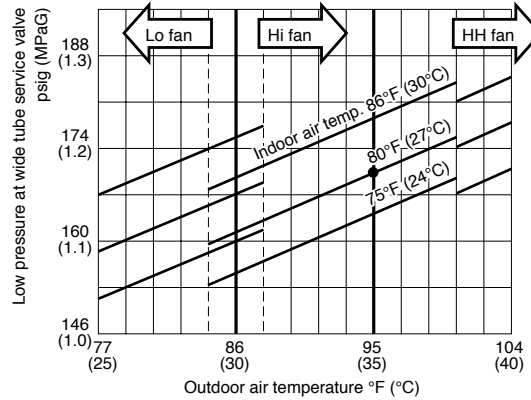

(2) Operating current performance chart

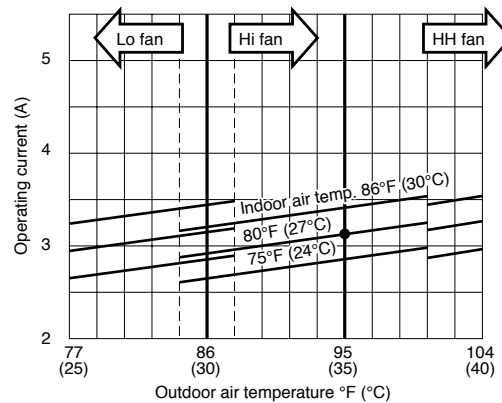

(3) Indoor discharge air performance chart

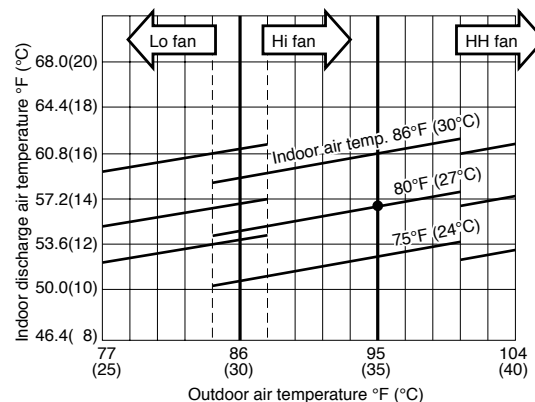

NOTE

- This performance chart shows operation of a single wall-mounted indoor unit. The performance chart will vary depending on the indoor unit type.
- Check each performance value in test-run mode. Electrical performance values represent a combined indoor/outdoor value. (In this case, be sure to stop all the indoor units where performance is not being checked.)
- The performance is for a tubing length of 24.6t (7.5m). If the tubing length is different, the performance chart will vary.

Outdoor Unit **CM1972** Indoor Unit **KMS0972 × 1**

■ **Cooling Characteristics**

(RH : 46%, Indoor fan speed : High fan)
(230V, 60Hz)

(1) Low pressure performance chart

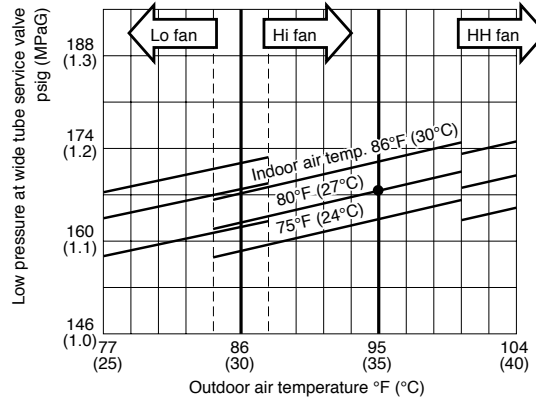

(2) Operating current performance chart

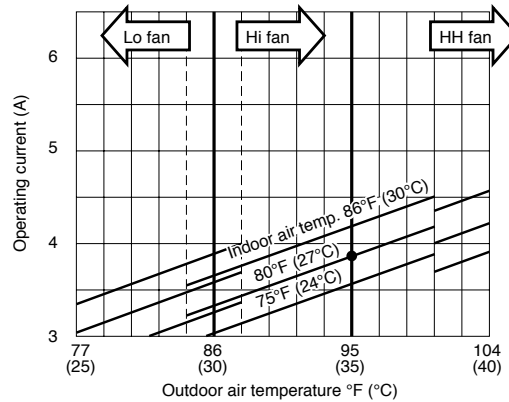

(3) Indoor discharge air performance chart

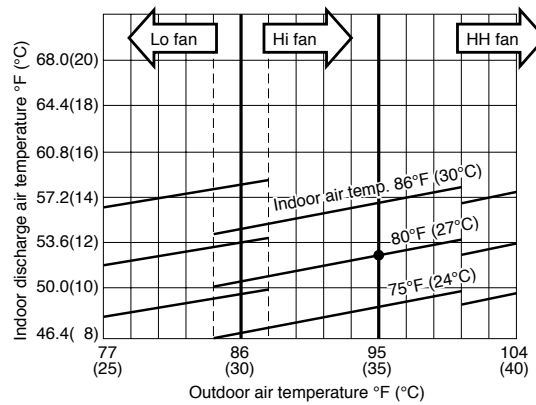

NOTE

- This performance chart shows operation of a single wall-mounted indoor unit. The performance chart will vary depending on the indoor unit type.
- Check each performance value in test-run mode. Electrical performance values represent a combined indoor/outdoor value. (In this case, be sure to stop all the indoor units where performance is not being checked.)
- The performance is for a tubing length of 24.6ft (7.5m). If the tubing length is different, the performance chart will vary.

Outdoor Unit **CM1972** Indoor Unit **KMS1272 × 1**

■ **Cooling Characteristics**

(RH : 46%, Indoor fan speed : High fan)

(230V, 60Hz)

(1) **Low pressure performance chart**

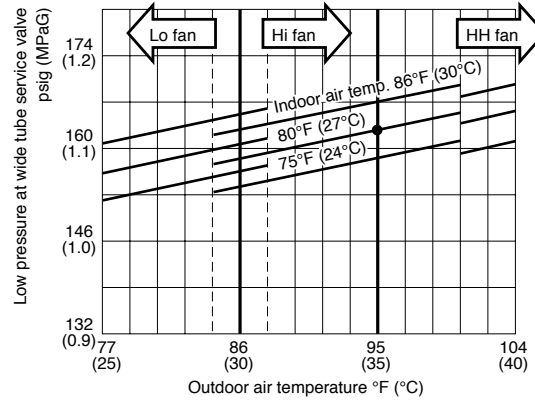

(2) **Operating current performance chart**

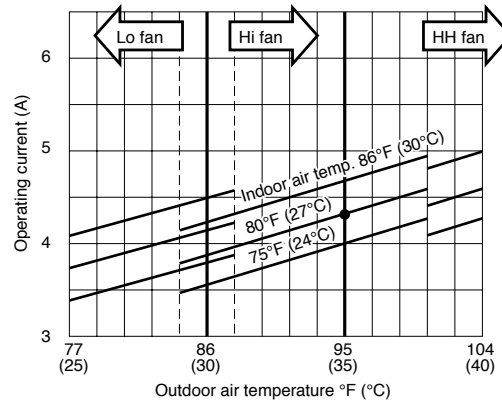

(3) **Indoor discharge air performance chart**

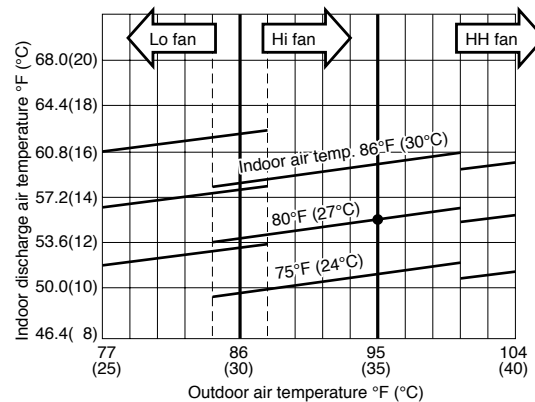

NOTE

- This performance chart shows operation of a single wall-mounted indoor unit. The performance chart will vary depending on the indoor unit type.
- Check each performance value in test-run mode. Electrical performance values represent a combined indoor/outdoor value. (In this case, be sure to stop all the indoor units where performance is not being checked.)
- The performance is for a tubing length of 24.6ft (7.5m). If the tubing length is different, the performance chart will vary.

Outdoor Unit **CM1972** Indoor Unit **KMS1872 × 1**

■ Cooling Characteristics

(RH : 46%, Indoor fan speed : High fan)
(230V, 60Hz)

(1) Low pressure performance chart

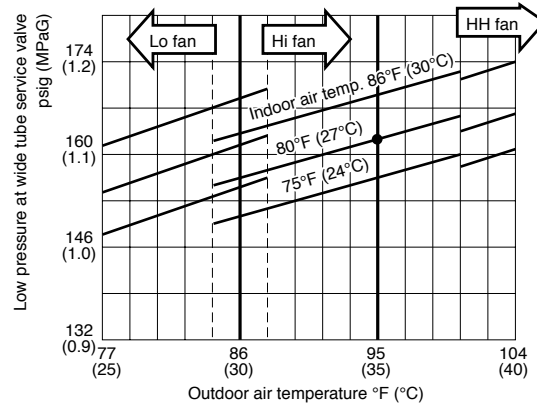

(2) Operating current performance chart

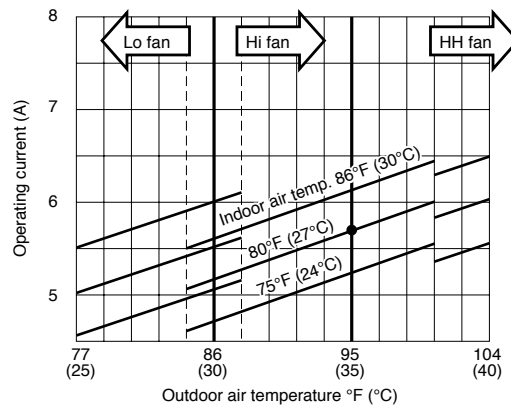

(3) Indoor discharge air performance chart

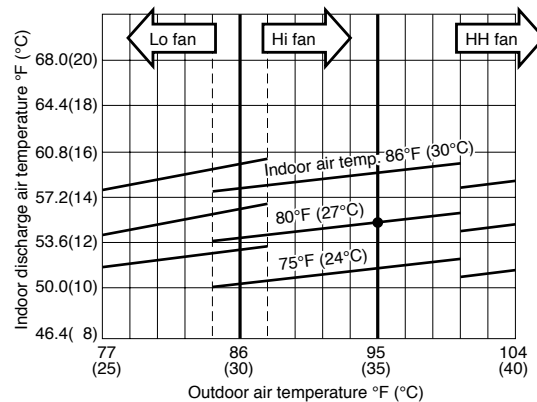

NOTE

- This performance chart shows operation of a single wall-mounted indoor unit. The performance chart will vary depending on the indoor unit type.
- Check each performance value in test-run mode. Electrical performance values represent a combined indoor/outdoor value. (In this case, be sure to stop all the indoor units where performance is not being checked.)
- The performance is for a tubing length of 24.6ft (7.5m). If the tubing length is different, the performance chart will vary.

5-1-2. Temperature Charts (CM2472)

Outdoor Unit **CM2472** Indoor Unit **KMS0772 × 1**

■ Cooling Characteristics

(RH : 46%, Indoor fan speed : High fan)
(230V, 60Hz)

(1) Low pressure performance chart

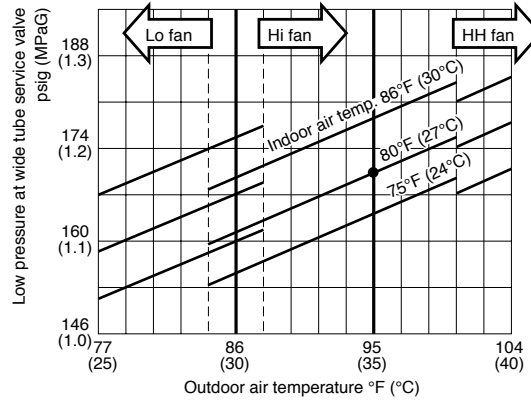

(2) Operating current performance chart

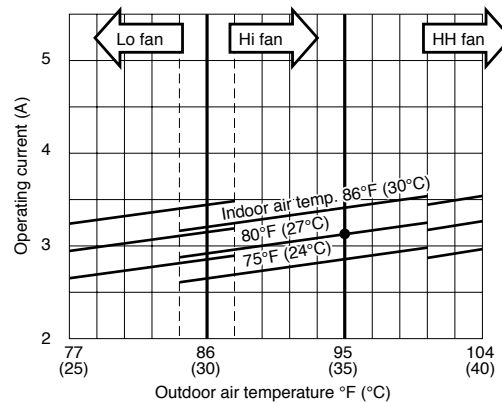

(3) Indoor discharge air performance chart

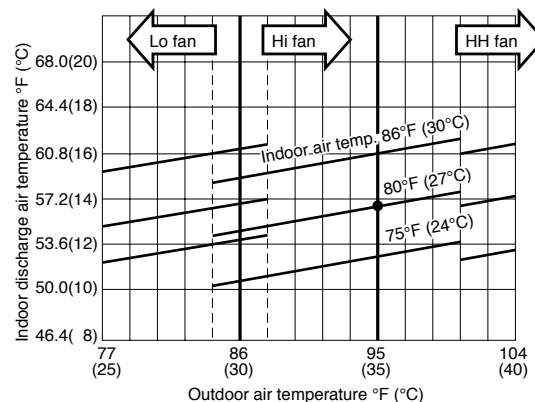

NOTE

- This performance chart shows operation of a single wall-mounted indoor unit. The performance chart will vary depending on the indoor unit type.
- Check each performance value in test-run mode. Electrical performance values represent a combined indoor/outdoor value. (In this case, be sure to stop all the indoor units where performance is not being checked.)
- The performance is for a tubing length of 24.6t (7.5m). If the tubing length is different, the performance chart will vary.

Outdoor Unit **CM2472** Indoor Unit **KMS0972 × 1**

■ **Cooling Characteristics**

(RH : 46%, Indoor fan speed : High fan)
(230V, 60Hz)

(1) Low pressure performance chart

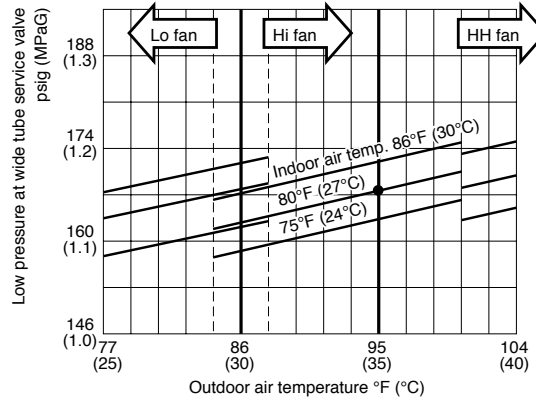

(2) Operating current performance chart

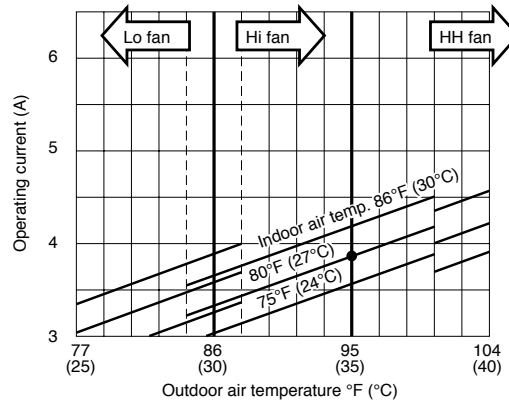

(3) Indoor discharge air performance chart

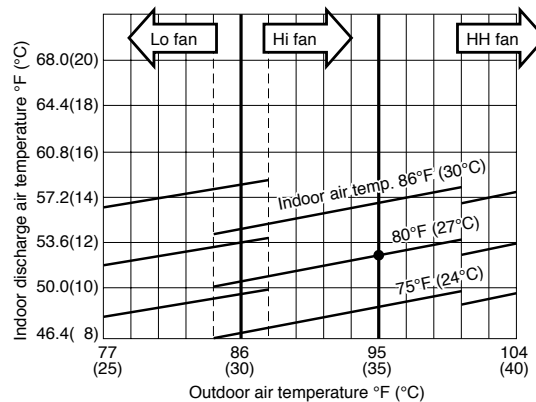

NOTE

- This performance chart shows operation of a single wall-mounted indoor unit. The performance chart will vary depending on the indoor unit type.
- Check each performance value in test-run mode. Electrical performance values represent a combined indoor/outdoor value. (In this case, be sure to stop all the indoor units where performance is not being checked.)
- The performance is for a tubing length of 24.6ft (7.5m). If the tubing length is different, the performance chart will vary.

Outdoor Unit **CM2472** Indoor Unit **KMS1272 × 1**

■ **Cooling Characteristics**

(RH : 46%, Indoor fan speed : High fan)

(230V, 60Hz)

(1) **Low pressure performance chart**

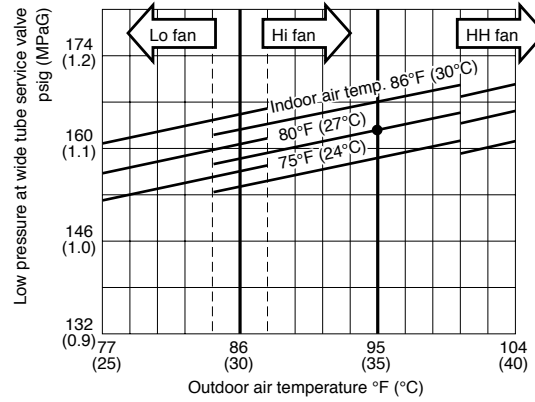

(2) **Operating current performance chart**

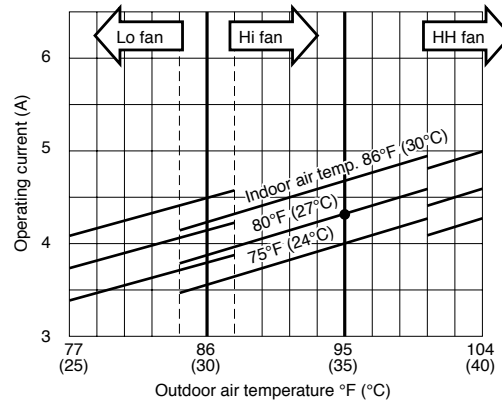

(3) **Indoor discharge air performance chart**

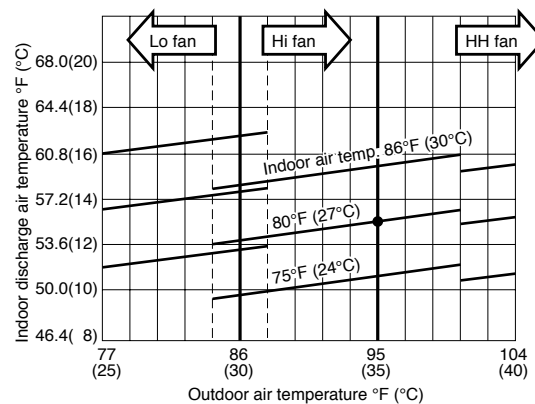

NOTE

- This performance chart shows operation of a single wall-mounted indoor unit. The performance chart will vary depending on the indoor unit type.
- Check each performance value in test-run mode. Electrical performance values represent a combined indoor/outdoor value. (In this case, be sure to stop all the indoor units where performance is not being checked.)
- The performance is for a tubing length of 24.6ft (7.5m). If the tubing length is different, the performance chart will vary.

Outdoor Unit **CM2472** Indoor Unit **KMS1872 × 1**

■ **Cooling Characteristics**

(RH : 46%, Indoor fan speed : High fan)
(230V, 60Hz)

(1) Low pressure performance chart

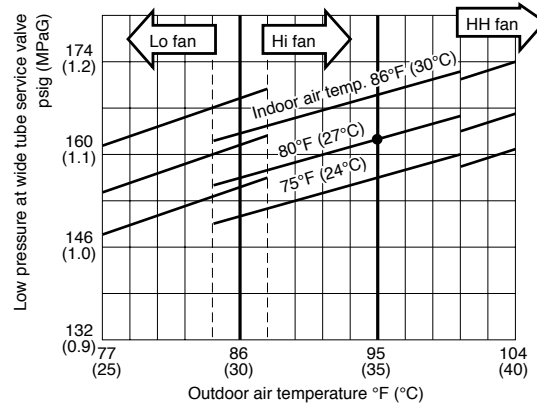

(2) Operating current performance chart

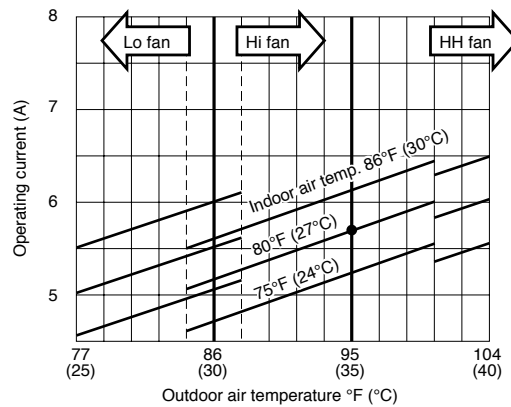

(3) Indoor discharge air performance chart

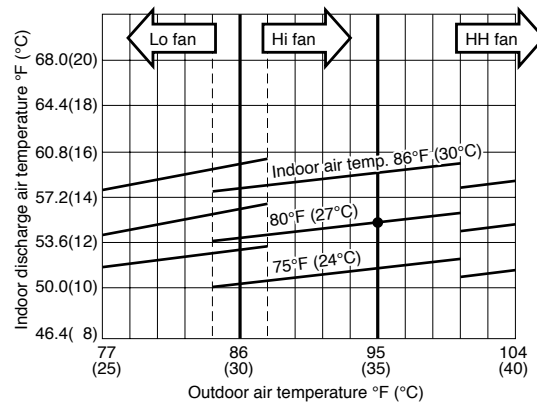

NOTE

- This performance chart shows operation of a single wall-mounted indoor unit. The performance chart will vary depending on the indoor unit type.
- Check each performance value in test-run mode. Electrical performance values represent a combined indoor/outdoor value. (In this case, be sure to stop all the indoor units where performance is not being checked.)
- The performance is for a tubing length of 24.6ft (7.5m). If the tubing length is different, the performance chart will vary.

Outdoor Unit **CM2472** Indoor Unit **KMS2472 × 1**

■ **Cooling Characteristics**

(RH : 46%, Indoor fan speed : High fan)
(230V, 60Hz)

(1) Low pressure performance chart

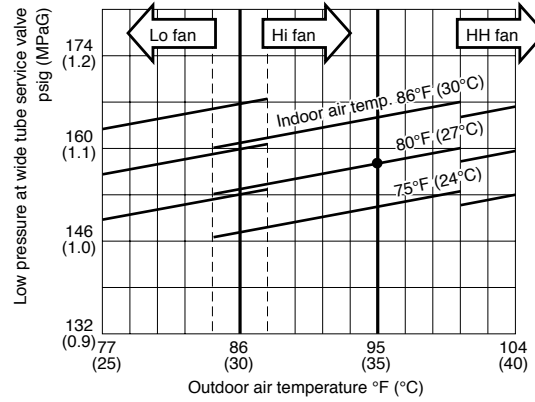

(2) Operating current performance chart

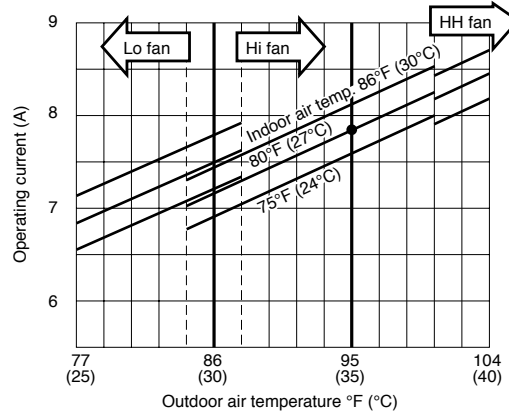

(3) Indoor discharge air performance chart

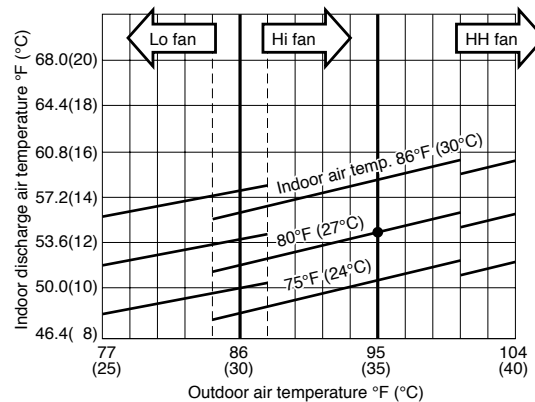

NOTE

- This performance chart shows operation of a single wall-mounted indoor unit. The performance chart will vary depending on the indoor unit type.
- Check each performance value in test-run mode. Electrical performance values represent a combined indoor/outdoor value. (In this case, be sure to stop all the indoor units where performance is not being checked.)
- The performance is for a tubing length of 24.6ft (7.5m). If the tubing length is different, the performance chart will vary.

5-1-3. Temperature Charts (CM3172)

Outdoor Unit **CM3172** Indoor Unit **KMS0772 × 1**

■ Cooling Characteristics
 (RH : 46%, Indoor fan speed : High fan)
 (230V, 60Hz)

(1) Low pressure performance chart

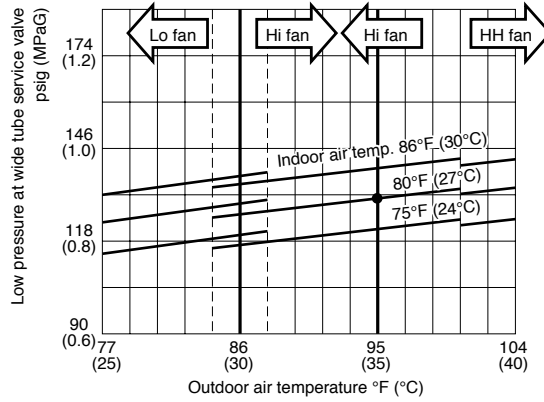

(2) Operating current performance chart

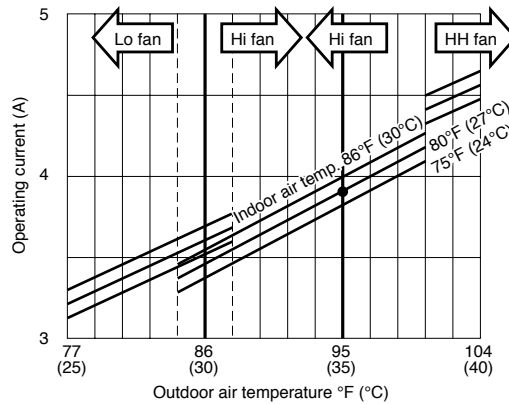

(3) Indoor discharge air performance chart

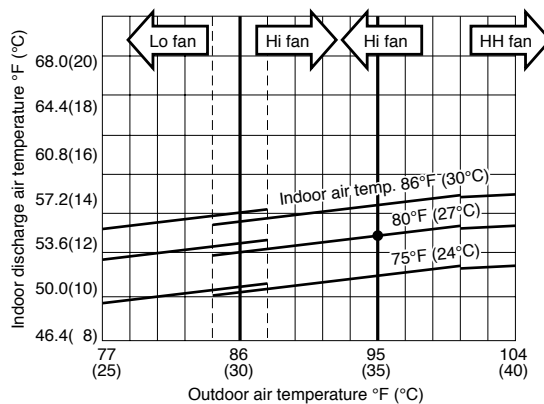

NOTE

- This performance chart shows operation of a single wall-mounted indoor unit. The performance chart will vary depending on the indoor unit type.
- Check each performance value in test-run mode. Electrical performance values represent a combined indoor/outdoor value. (In this case, be sure to stop all the indoor units where performance is not being checked.)
- The performance is for a tubing length of 24.6ft (7.5m). If the tubing length is different, the performance chart will vary.

Outdoor Unit **CM3172** Indoor Unit **KMS0972 × 1**

■ **Cooling Characteristics**

(RH : 46%, Indoor fan speed : High fan)
(230V, 60Hz)

(1) Low pressure performance chart

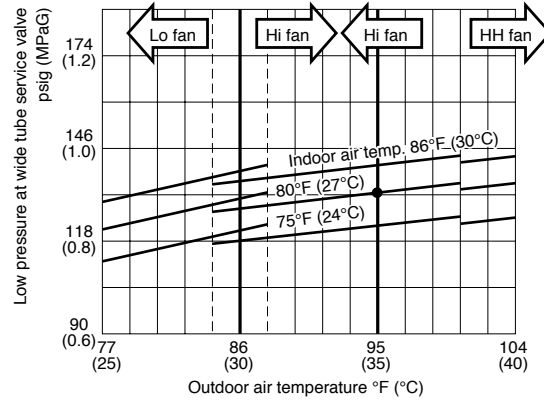

(2) Operating current performance chart

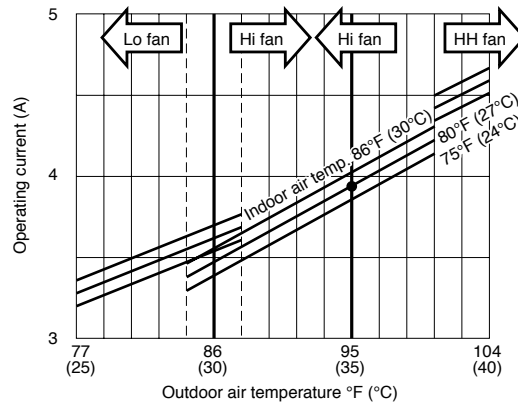

(3) Indoor discharge air performance chart

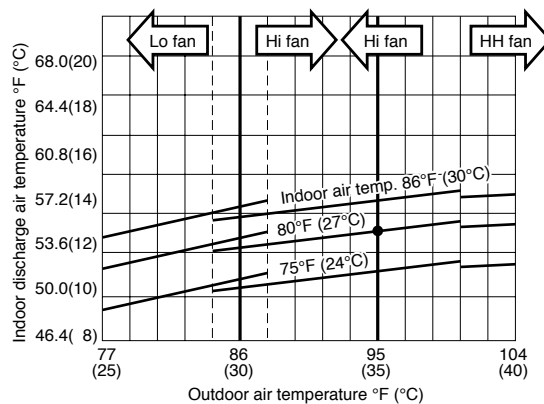

NOTE

- This performance chart shows operation of a single wall-mounted indoor unit. The performance chart will vary depending on the indoor unit type.
- Check each performance value in test-run mode. Electrical performance values represent a combined indoor/outdoor value. (In this case, be sure to stop all the indoor units where performance is not being checked.)
- The performance is for a tubing length of 24.6ft (7.5m). If the tubing length is different, the performance chart will vary.

Outdoor Unit **CM3172** Indoor Unit **KMS1272 × 1**

■ **Cooling Characteristics**

(RH : 46%, Indoor fan speed : High fan)
(230V, 60Hz)

(1) Low pressure performance chart

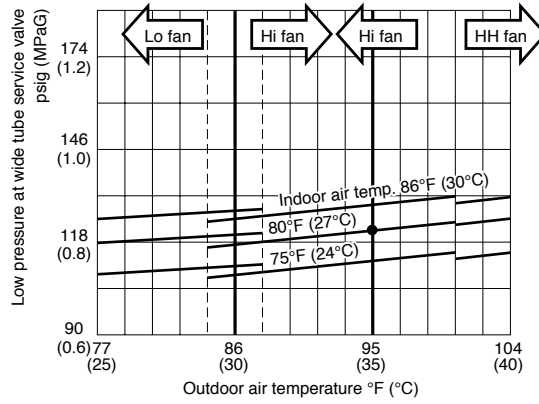

(2) Operating current performance chart

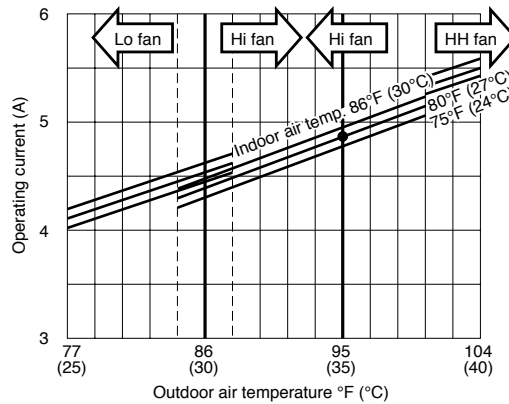

(3) Indoor discharge air performance chart

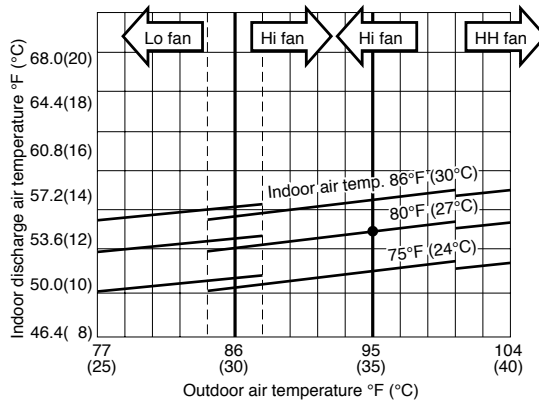

NOTE

- This performance chart shows operation of a single wall-mounted indoor unit. The performance chart will vary depending on the indoor unit type.
- Check each performance value in test-run mode. Electrical performance values represent a combined indoor/outdoor value. (In this case, be sure to stop all the indoor units where performance is not being checked.)
- The performance is for a tubing length of 24.6ft (7.5m). If the tubing length is different, the performance chart will vary.

Outdoor Unit **CM3172** Indoor Unit **KMS1872 × 1**

■ **Cooling Characteristics**

(RH : 46%, Indoor fan speed : High fan)
(230V, 60Hz)

(1) Low pressure performance chart

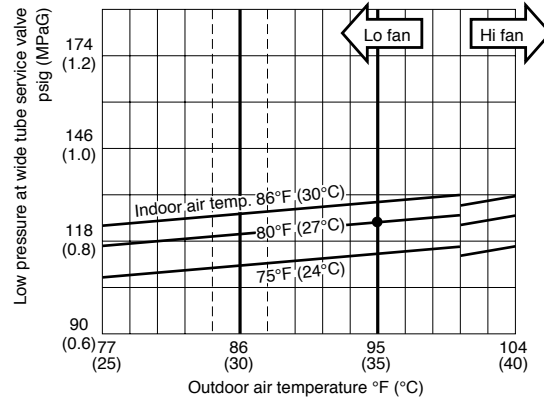

(2) Operating current performance chart

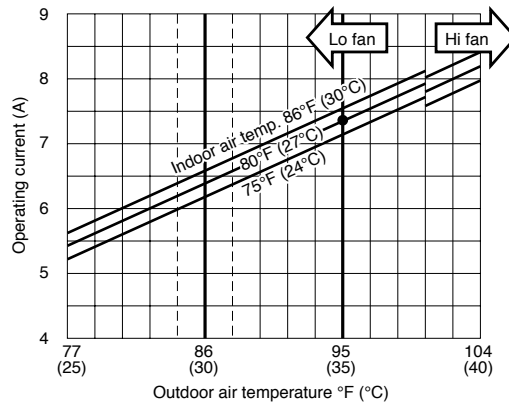

(3) Indoor discharge air performance chart

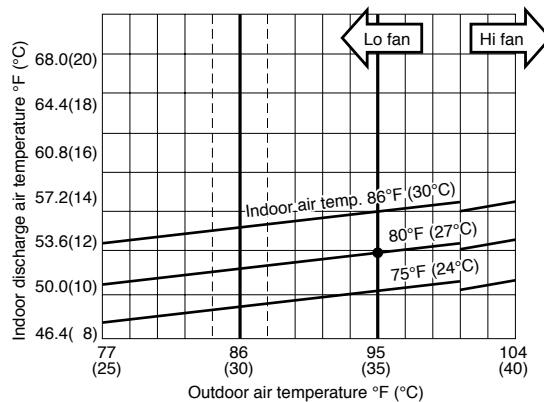

NOTE

- This performance chart shows operation of a single wall-mounted indoor unit. The performance chart will vary depending on the indoor unit type.
- Check each performance value in test-run mode. Electrical performance values represent a combined indoor/outdoor value. (In this case, be sure to stop all the indoor units where performance is not being checked.)
- The performance is for a tubing length of 24.6ft (7.5m). If the tubing length is different, the performance chart will vary.

Outdoor Unit **CM3172** Indoor Unit **KMS2472 × 1**

■ **Cooling Characteristics**
 (RH : 46%, Indoor fan speed : High fan)
 (230V, 60Hz)

(1) Low pressure performance chart

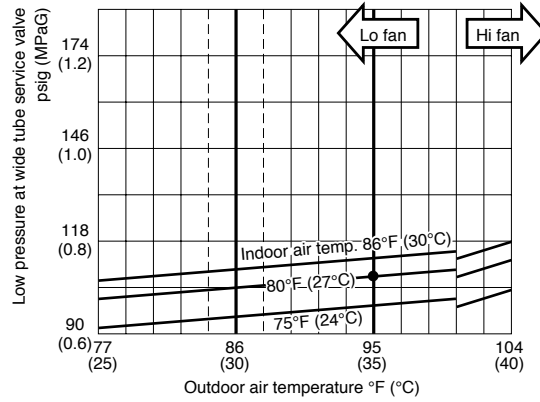

(2) Operating current performance chart

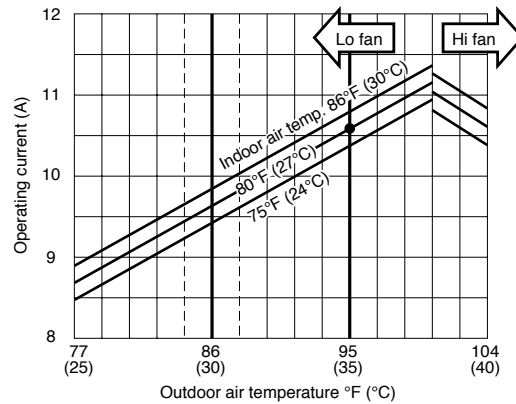

(3) Indoor discharge air performance chart

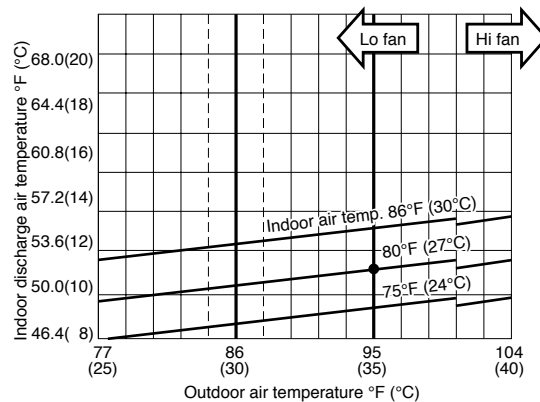

NOTE

- This performance chart shows operation of a single wall-mounted indoor unit. The performance chart will vary depending on the indoor unit type.
- Check each performance value in test-run mode. Electrical performance values represent a combined indoor/outdoor value. (In this case, be sure to stop all the indoor units where performance is not being checked.)
- The performance is for a tubing length of 24.6ft (7.5m). If the tubing length is different, the performance chart will vary.

5-2. Cooling Capacity

Outdoor Unit : **CM1972**

Indoor Unit : **KMS0972 × 3**

Power Supply : 230V Single Phase 60Hz

< Cooling Capacity >

RATING CAPACITY:		19,700 BTU/h		AIR FLOW RATE:		883 CFM		
INDOOR		OUTDOOR						
ENT. TEMP. °F (°C)		AMBIENT TEMP. °F (°C)						
W.B.	D.B.		65 (18.3)	75 (23.9)	85 (29.4)	95 (35.0)	105 (40.6)	115 (46.1)
59 (15.0)		TC	19,800	19,100	18,350	17,770	16,890	15,940
	72 (22.2)	SHC	17,470	17,130	16,790	16,610	16,270	15,760
	76 (24.4)	SHC	19,800	19,100	18,350	17,770	16,890	15,940
	80 (26.7)	SHC	19,800	19,100	18,350	17,770	16,890	15,940
	84 (28.9)	SHC	19,800	19,100	18,350	17,770	16,890	15,940
	88 (31.1)	SHC	19,800	19,100	18,350	17,770	16,890	15,940
63 (17.2)		TC	20,790	20,060	19,290	18,720	17,800	16,820
	72 (22.2)	SHC	14,210	13,870	13,530	13,360	13,010	12,670
	76 (24.4)	SHC	17,130	16,960	16,610	16,270	15,930	15,590
	80 (26.7)	SHC	20,390	20,040	19,290	18,720	17,800	16,820
	84 (28.9)	SHC	20,790	20,060	19,290	18,720	17,800	16,820
	88 (31.1)	SHC	20,790	20,060	19,290	18,720	17,800	16,820
67 (19.4)		TC	21,790	21,050	20,240	# 19,700	18,750	17,720
	72 (22.2)	SHC	10,960	10,610	10,270	10,100	9,760	9,410
	76 (24.4)	SHC	13,870	13,700	13,360	13,190	12,840	12,330
	80 (26.7)	SHC	16,960	16,790	16,440	16,270	15,930	15,590
	84 (28.9)	SHC	20,040	19,700	19,360	19,190	18,750	17,720
	88 (31.1)	SHC	21,790	21,050	20,240	19,700	18,750	17,720
71 (21.7)		TC	22,800	22,040	21,210	20,700	19,720	18,470
	72 (22.2)	SHC	7,360	7,190	6,840	6,670	6,330	5,980
	76 (24.4)	SHC	10,440	10,100	9,930	9,760	9,410	8,900
	80 (26.7)	SHC	13,530	13,190	13,010	12,840	12,500	11,990
	84 (28.9)	SHC	16,440	16,270	15,930	15,760	15,410	15,070
	88 (31.1)	SHC	19,530	19,190	19,010	18,840	18,500	17,990
75 (23.9)		TC	23,690	22,920	22,080	21,600	20,590	18,950
	76 (24.4)	SHC	7,010	6,840	6,500	6,330	6,160	5,640
	80 (26.7)	SHC	10,100	9,930	9,590	9,410	9,240	8,730
	84 (28.9)	SHC	13,190	12,840	12,670	12,500	12,160	11,640
	88 (31.1)	SHC	16,100	15,930	15,590	15,410	15,070	14,730

TC : Total Cooling Capacity (BTU/h) SHC : Sensible Heat Capacity (BTU/h)

NOTE

- Rating conditions (#) : Indoor Unit Entering Air Temp. 80 °F (26.7 °C) D.B. / 67 °F (19.4 °C) W.B.
: Outdoor Ambient Temp. 95 °F (35 °C) D.B.
- Above data does not take Freeze Prevention Protection during cooling operation into account.
For this reason, the value may vary from the actual cooling characteristics.
- Above data represents the value when the operation frequency of a compressor is fixed.

Outdoor Unit : **CM2472**

Indoor Unit : **KMS0972 × 3**

Power Supply : 230V Single Phase 60Hz

< Cooling Capacity >

RATING CAPACITY:		25,400 BTU/h		AIR FLOW RATE:		883 CFM		
INDOOR		OUTDOOR						
ENT. TEMP. °F (°C)		AMBIENT TEMP. °F (°C)						
W.B.	D.B.		65 (18.3)	75 (23.9)	85 (29.4)	95 (35.0)	105 (40.6)	115 (46.1)
59 (15.0)		TC	25,690	24,800	23,840	23,190	22,040	17,290
	72 (22.2)	SHC	20,210	19,870	19,360	19,010	18,500	16,440
	76 (24.4)	SHC	23,130	22,790	22,270	22,100	21,410	17,290
	80 (26.7)	SHC	25,690	24,800	23,840	23,190	22,040	17,290
	84 (28.9)	SHC	25,690	24,800	23,840	23,190	22,040	17,290
	88 (31.1)	SHC	25,690	24,800	23,840	23,190	22,040	17,290
63 (17.2)		TC	26,810	25,900	24,910	24,290	23,110	17,700
	72 (22.2)	SHC	16,790	16,440	15,930	15,760	15,240	13,010
	76 (24.4)	SHC	19,700	19,360	19,010	18,670	18,160	15,930
	80 (26.7)	SHC	22,960	22,440	22,100	21,760	21,240	17,700
	84 (28.9)	SHC	25,870	25,530	24,910	24,290	23,110	17,700
	88 (31.1)	SHC	26,810	25,900	24,910	24,290	23,110	17,700
67 (19.4)		TC	27,910	26,980	25,970	# 25,400	24,180	18,070
	72 (22.2)	SHC	13,360	13,010	12,500	12,330	11,810	9,590
	76 (24.4)	SHC	16,270	15,930	15,590	15,240	14,900	12,500
	80 (26.7)	SHC	19,360	19,010	18,670	18,330	17,990	15,590
	84 (28.9)	SHC	22,440	22,100	21,590	21,410	20,900	18,070
	88 (31.1)	SHC	25,360	25,020	24,670	24,330	23,810	18,070
71 (21.7)		TC	28,980	28,030	26,990	26,500	25,010	18,380
	72 (22.2)	SHC	9,590	9,240	8,900	8,730	8,210	5,980
	76 (24.4)	SHC	12,670	12,330	11,810	11,640	11,130	8,900
	80 (26.7)	SHC	15,760	15,410	15,070	14,730	14,210	11,990
	84 (28.9)	SHC	18,670	18,330	17,990	17,810	17,300	15,070
	88 (31.1)	SHC	21,590	21,240	20,900	20,730	20,210	17,990
75 (23.9)		TC	29,880	28,920	27,870	27,460	25,330	18,590
	76 (24.4)	SHC	9,070	8,730	8,390	8,210	7,530	5,470
	80 (26.7)	SHC	12,160	11,810	11,470	11,300	10,610	8,560
	84 (28.9)	SHC	15,070	14,730	14,390	14,390	13,700	11,640
	88 (31.1)	SHC	18,160	17,810	17,470	17,300	16,610	14,560

TC : Total Cooling Capacity (BTU/h) SHC : Sensible Heat Capacity (BTU/h)

NOTE

1. Rating conditions (#) : Indoor Unit Entering Air Temp. 80 °F (26.7 °C) D.B. / 67 °F (19.4 °C) W.B.
: Outdoor Ambient Temp. 95 °F (35 °C) D.B.
2. Above data does not take Freeze Prevention Protection during cooling operation into account.
For this reason, the value may vary from the actual cooling characteristics.
3. Above data represents the value when the operation frequency of a compressor is fixed.

Outdoor Unit : **CM3172**

Indoor Unit : **KMS0972 × 4**

Power Supply : 230V Single Phase 60Hz

< Cooling Capacity >

RATING CAPACITY:		30,600 BTU/h		AIR FLOW RATE:		1,177 CFM		
INDOOR		OUTDOOR						
ENT. TEMP. °F (°C)		AMBIENT TEMP. °F (°C)						
W.B.	D.B.		65 (18.3)	75 (23.9)	85 (29.4)	95 (35.0)	105 (40.6)	115 (46.1)
59 (15.0)		TC	31,170	30,000	28,730	28,010	22,960	16,690
	72 (22.2)	SHC	25,580	24,900	24,440	23,980	21,700	16,690
	76 (24.4)	SHC	29,470	29,010	28,320	28,010	22,960	16,690
	80 (26.7)	SHC	31,170	30,000	28,730	28,010	22,960	16,690
	84 (28.9)	SHC	31,170	30,000	28,730	28,010	22,960	16,690
	88 (31.1)	SHC	31,170	30,000	28,730	28,010	22,960	16,690
63 (17.2)		TC	32,490	31,280	29,960	29,310	23,400	16,970
	72 (22.2)	SHC	21,010	20,550	19,870	19,640	17,120	14,610
	76 (24.4)	SHC	24,900	24,440	23,980	23,520	21,240	16,970
	80 (26.7)	SHC	29,010	28,550	28,100	27,640	23,400	16,970
	84 (28.9)	SHC	32,490	31,280	29,960	29,310	23,400	16,970
	88 (31.1)	SHC	32,490	31,280	29,960	29,310	23,400	16,970
67 (19.4)		TC	33,790	32,540	31,170	# 30,600	23,770	17,200
	72 (22.2)	SHC	16,440	15,980	15,290	15,070	12,550	10,270
	76 (24.4)	SHC	20,320	19,870	19,410	19,180	16,670	14,150
	80 (26.7)	SHC	24,440	23,980	23,520	23,300	20,780	17,200
	84 (28.9)	SHC	28,550	28,100	27,410	27,180	23,770	17,200
	88 (31.1)	SHC	32,440	31,980	31,170	30,600	23,770	17,200
71 (21.7)		TC	35,020	33,730	32,320	31,860	24,020	17,350
	72 (22.2)	SHC	11,410	10,950	10,490	10,490	7,750	5,690
	76 (24.4)	SHC	15,520	15,070	14,610	14,380	11,640	9,580
	80 (26.7)	SHC	19,640	19,180	18,720	18,500	15,980	13,690
	84 (28.9)	SHC	23,520	23,070	22,610	22,610	19,870	17,350
	88 (31.1)	SHC	27,640	27,180	26,720	26,500	23,750	17,350
75 (23.9)		TC	36,040	34,730	33,270	32,940	24,130	17,390
	76 (24.4)	SHC	10,720	10,270	9,810	9,810	7,070	5,240
	80 (26.7)	SHC	14,840	14,610	14,150	13,920	11,180	9,350
	84 (28.9)	SHC	18,950	18,500	18,040	17,810	15,290	13,240
	88 (31.1)	SHC	22,840	22,380	21,920	21,920	19,180	17,350

TC : Total Cooling Capacity (BTU/h) SHC : Sensible Heat Capacity (BTU/h)

NOTE

- Rating conditions (#) : Indoor Unit Entering Air Temp. 80 °F (26.7 °C) D.B. / 67 °F (19.4 °C) W.B.
: Outdoor Ambient Temp. 95 °F (35 °C) D.B.
- Above data does not take Freeze Prevention Protection during cooling operation into account.
For this reason, the value may vary from the actual cooling characteristics.
- Above data represents the value when the operation frequency of a compressor is fixed.

6. ELECTRICAL DATA

6-1. Electric Wiring Diagrams

Outdoor Unit CM1972



WARNING

To avoid electrical shock hazard, be sure to disconnect power before checking, servicing and/or cleaning any electrical parts.

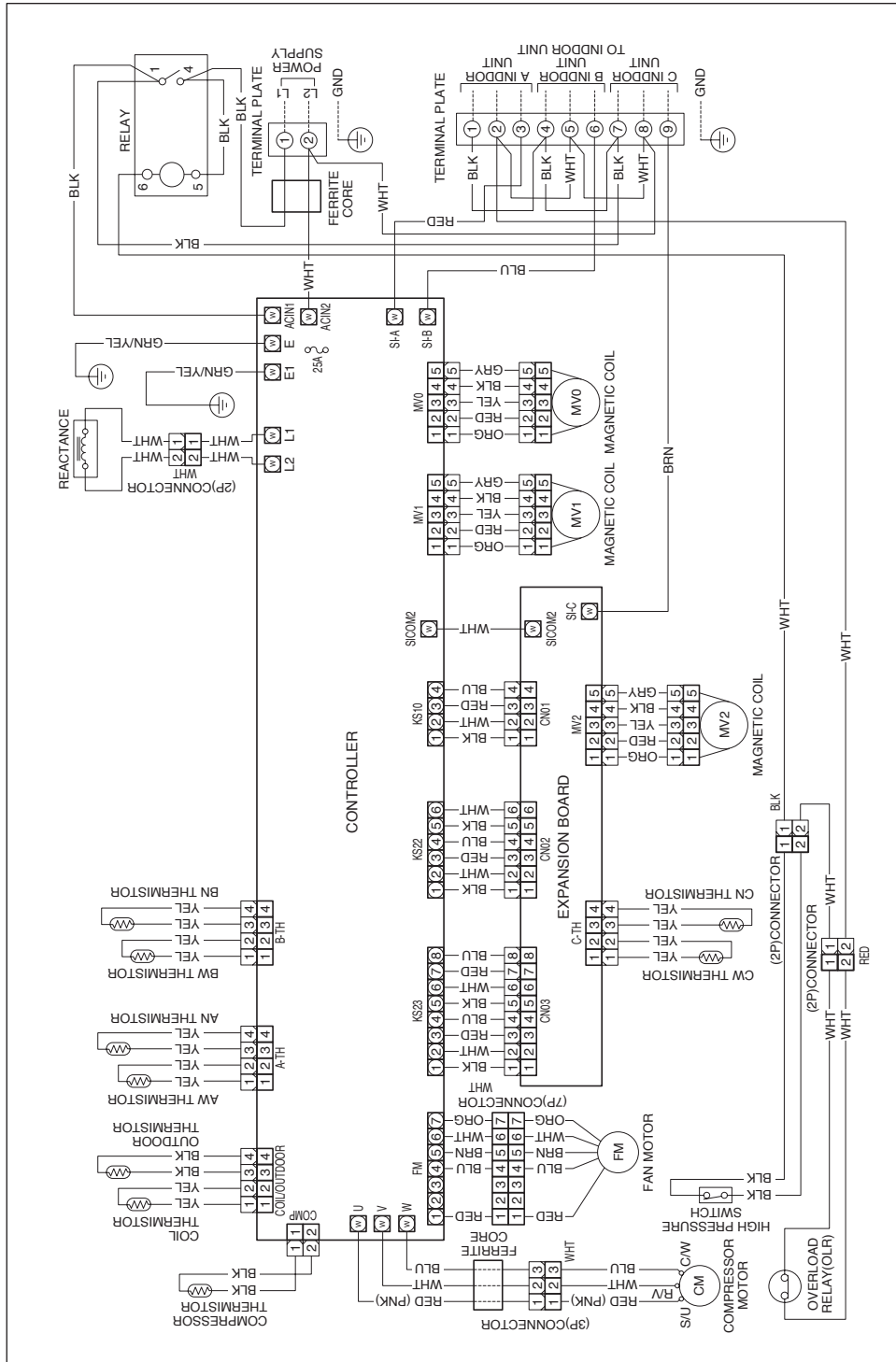

8FA2-5257-58800-1



WARNING

To avoid electrical shock hazard, be sure to disconnect power before checking, servicing and/or cleaning any electrical parts.

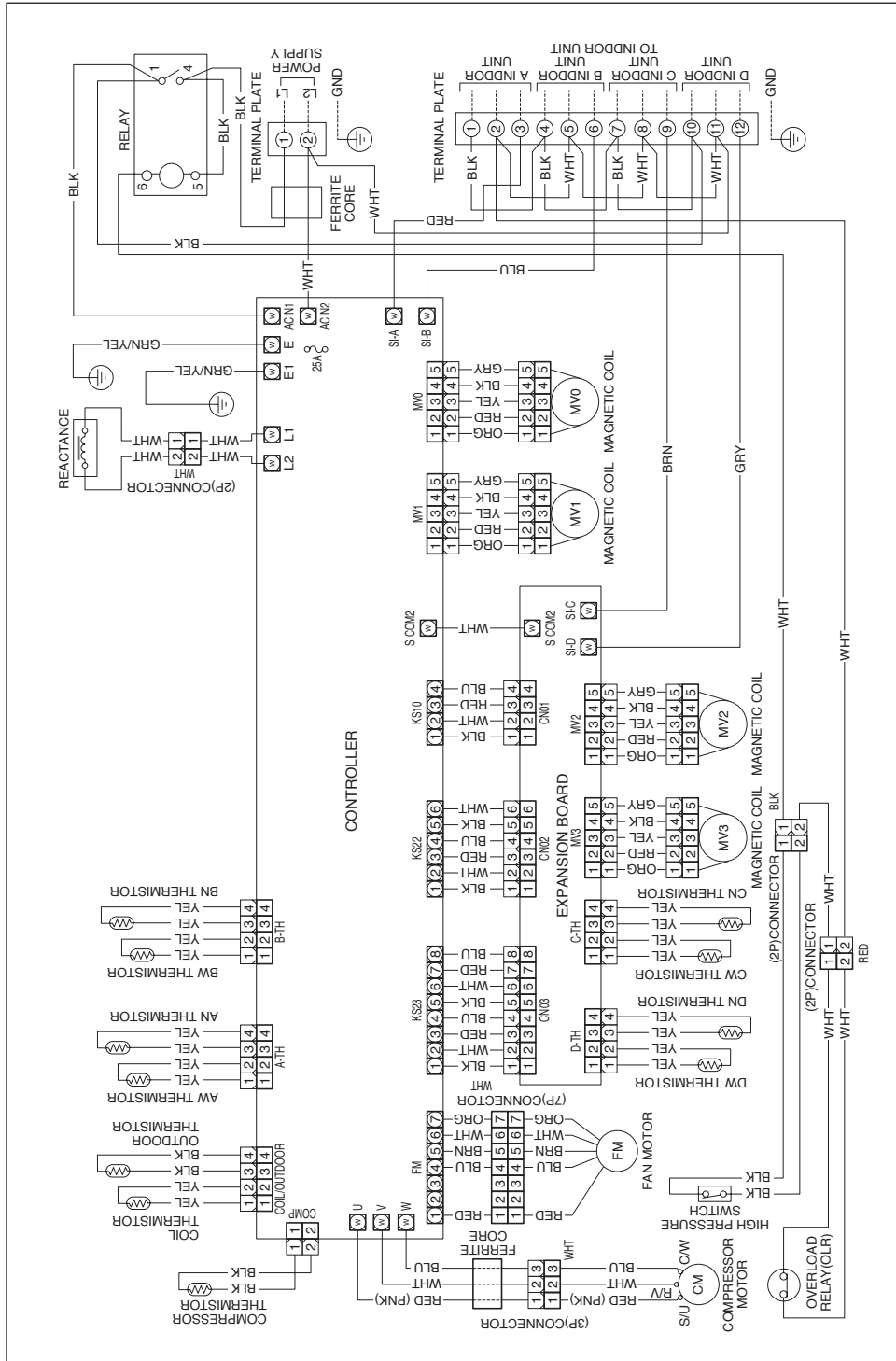

8FA2-5257-59000-1



WARNING

To avoid electrical shock hazard, be sure to disconnect power before checking, servicing and/or cleaning any electrical parts.

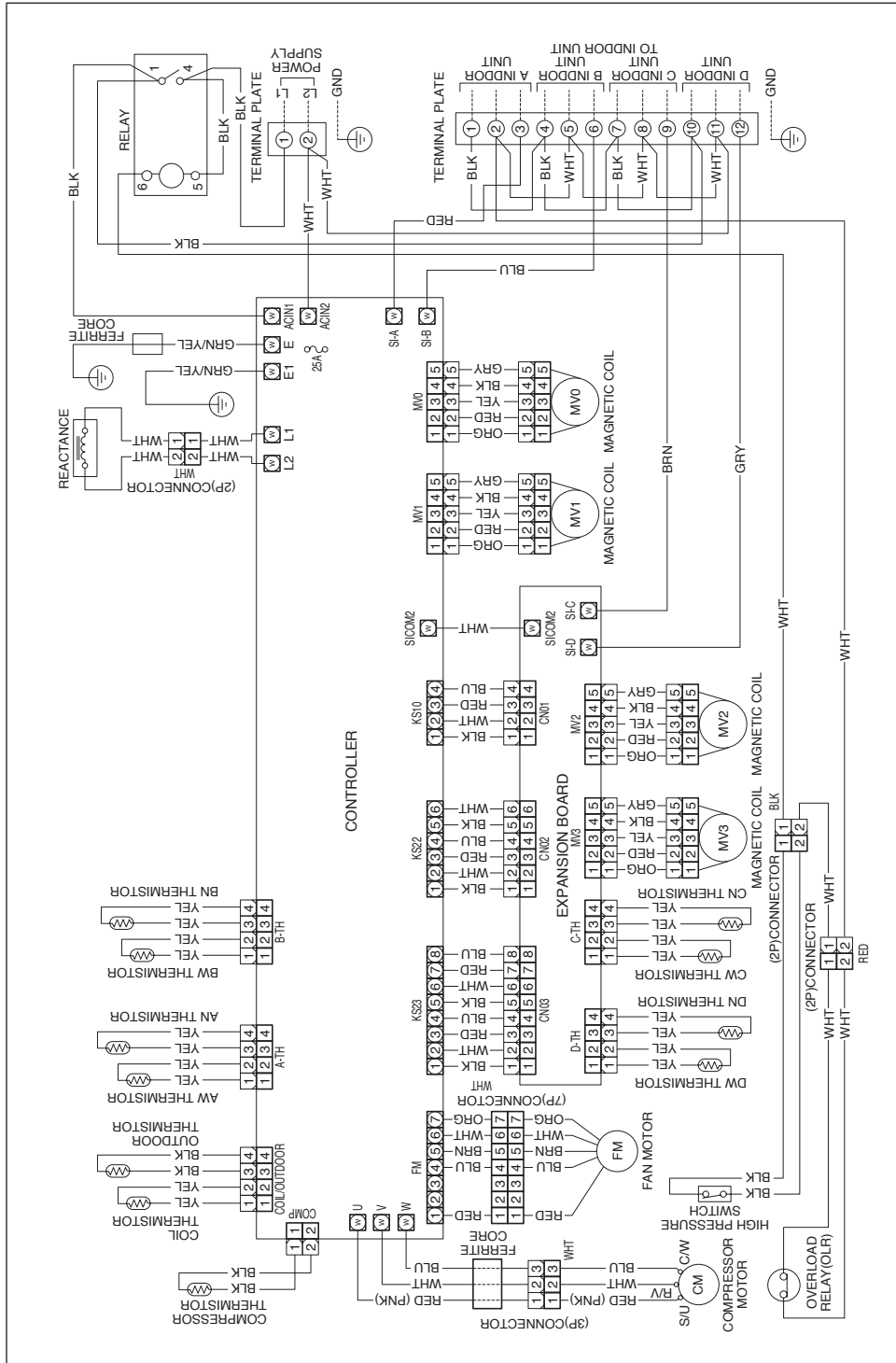

8FA2-5257-89300-1

7. FUNCTIONS

7-1. Explanation of Functions

NOTE The numerical values such as temperature, frequency, time and current in parentheses are an example of CM3172 and the values are different from the other models.

	Control/conditions	Unit operation	Explanation
INITIAL	Breaker is ON.	_____	Power is supplied to the indoor and outdoor unit control circuits, however the unit remains stopped. Positioning of the outdoor unit electric expansion valve is performed.
	The ON/OFF operation button on the remote controller is pressed.	If automatic operation mode has been selected with the remote controller, operation begins in SENSOR DRY, or COOL mode depending on the room temperature and outdoor temperature at the time operation starts.	<ul style="list-style-type: none"> ● This applies in the case of automatic COOL operation.
	 Depending on the operational mode, refer to the SENSOR DRY, or COOL item.		

	Control/conditions	Unit operation	Explanation
COOL	The ON/OFF operation button on the remote controller is pressed.	<ul style="list-style-type: none"> The operation lamp illuminates. The indoor fan operates at the set fan speed. The outdoor unit stops. 	The outdoor unit does not operate for 3 minutes even after the breaker is turned ON.
		The outdoor unit starts. (Compressor and the outdoor fan start.)	<ul style="list-style-type: none"> The frequency is increased at the rate of 0.5 Hz every 1 seconds.
		When the frequency reaches α Hz, frequency increases are stopped for a period of β seconds. (Refer to Table 1.)	This is in order to stabilize the return of oil to the compressor.
		The frequency then increases.	If the indoor and outdoor temperatures are high, the current peak cut-off activates, stopping any increases in frequency.
	The room temperature has reached the desired temperature.	The indoor temperature and the desired temperature are approximately equal.	Operating frequency is stabilized in order to maintain a comfortable environment.
	The thermostat turns OFF.	_____	The outdoor unit stops. (It does not stop if the thermostat for another indoor unit is ON.)
	The thermostat turns ON again.	After the thermostat turns ON again, the outdoor unit will not operate for 3 minutes, even if the room temperature increases above the desired temperature.	After 3 minutes, the outdoor unit begins operating automatically. During these 3 minutes, a pressure balance is achieved, allowing the compressor to start more easily.
	Freeze prevention	<ul style="list-style-type: none"> When the temperature of the indoor heat exchanger drops to approximately 35.6 °F or below, the compressor turns OFF, the outdoor fan turns OFF, and the indoor fan continues operating with no changes. <p style="text-align: center;">↓</p> <ul style="list-style-type: none"> Approximately 3 minutes later, if the temperature of the indoor heat exchanger is above 46.4 °F, the system returns to its original conditions. 	In order to protect against freezing, the compressor stops temporarily, until the temperature of the indoor heat exchanger has risen.
	Stop	All indicator lamps turn OFF. The indoor and outdoor units stop.	_____
Operation is restarted within 4 hours (only when AUTO mode is selected with the remote controller).	Starts operating in the same operating mode (COOL) and with the same temperature settings as before operation was stopped.	Within 4 hours after operation was stopped, it is assumed that there has been no significant change in the indoor and outdoor temperatures, and the previous conditions (COOL) are stored.	
Operation starts after 4 hours or more have passed.	New operating mode is determined based on the temperature conditions at the time the ON/OFF operation button is pressed.	_____	

Frequency control

α (Hz)	β (seconds)	
	Outdoor air temperature is below 32 °F.	Outdoor air temperature is 32 °F or higher.
(25) Hz	(120) seconds	(60) seconds
(35) Hz	(60) seconds	(30) seconds
(45) Hz	(60) seconds	(30) seconds
(55) Hz	(180) seconds	(90) seconds

Table 1

(1/f fluctuation fan)

	Control/conditions	Unit operation	Explanation
SENSOR DRY	The ON/OFF operation button on the remote controller is pressed.	<ul style="list-style-type: none"> ● The operation lamp illuminates. ● The indoor fan operates at the set fan speed. ● The outdoor unit stops. 	The outdoor unit does not operate for 3 minutes even after the breaker is turned ON.
		<p>The outdoor unit starts.</p> <p>(Compressor and the outdoor fan start.)</p>	<ul style="list-style-type: none"> ● The frequency is increased at the rate of 0.5 Hz every 1 seconds.
		When the frequency reaches α Hz, frequency increases are stopped for a period of β seconds. (Refer to Table 1.)	This is in order to stabilize the return of oil to the compressor.
		The frequency then increases.	If the indoor and outdoor temperatures are high, the current peak cut-off activates, stopping any increases in frequency.
	The room temperature reaches the desired temperature, and there is no need for further cooling.	<ul style="list-style-type: none"> ● DRY operation starts <p>DRY A operation</p> <ul style="list-style-type: none"> ● The indoor fan changes between "Low" and "LL" (very low) over a 6-minute cycle. This is 1/f fluctuation fan operation. (Refer to Fig. 1.) 	<p>Operating frequency is stabilized in order to maintain a comfortable environment.</p> <ul style="list-style-type: none"> ● Operates to effectively dehumidify the air while not excessively reducing the indoor temperature. ● The indoor unit operates at 1/f fluctuation fan operation, at a fan speed that does not cause a chilly feeling.
	The room temperature is 59 °F or higher, and is slightly too cold.	<p>DRY B operation</p> <p>(1) The indoor fan changes between "Low" and "LL" (very low) over a 6-minute cycle. This is 1/f fluctuation fan operation.</p> <p style="text-align: center;">↓</p> <p>(2) After approximately 3 minutes, the compressor turns OFF, the outdoor fan turns OFF, and the indoor fan turns OFF.</p> <p style="text-align: center;">↓</p> <p>(3) After approximately 6 minutes, the conditions return to (1).</p>	The compressor operates on a 3-minutes ON, 6-minutes OFF cycle, to prevent the room temperature from dropping too much.
	The room temperature is below 59 °F.	<ul style="list-style-type: none"> ● Monitoring operation begins. 	When monitoring operation begins, the compressor stops, and the indoor fan operates at "LL" (very low) speed.

● 1/f fluctuation fan

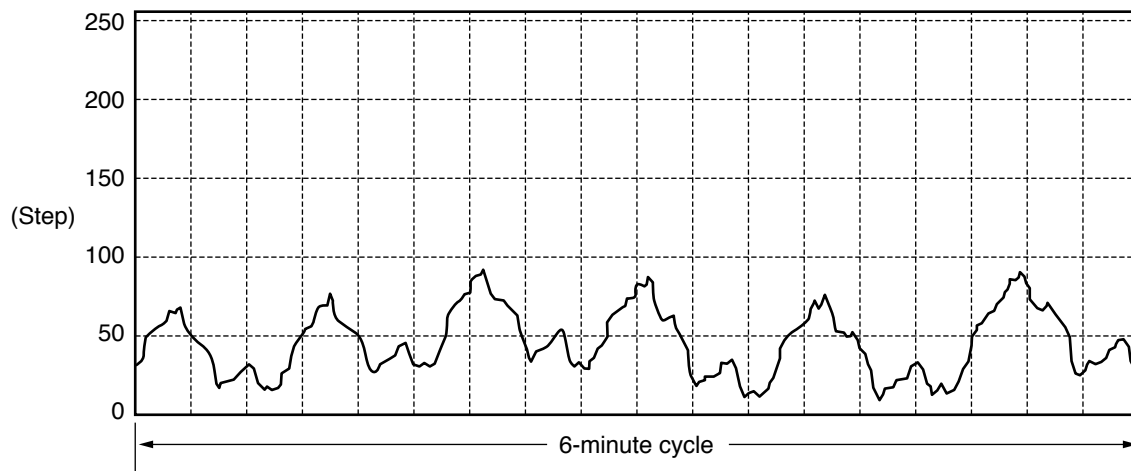



Fig. 1

7-2. Protective Functions

NOTE The numerical values such as temperature, frequency, time and current in parentheses are an example of CM3172 and the values are different from the other models.

7-2-1. Current Control

- The operating current may rise as a result of causes including increasing cooling loads or decreases in power voltage. In these cases, the operating frequency is automatically reduced, or operation is stopped, in order to control the operating current so that it is (20 A) or less.

As a result: 

- Power breakers and fuses will not be tripped.
- Operation can continue during this period with somewhat reduced cooling capacity.
- Operation at normal capacity is restored when the cause of the current rise is eliminated.

Description of function

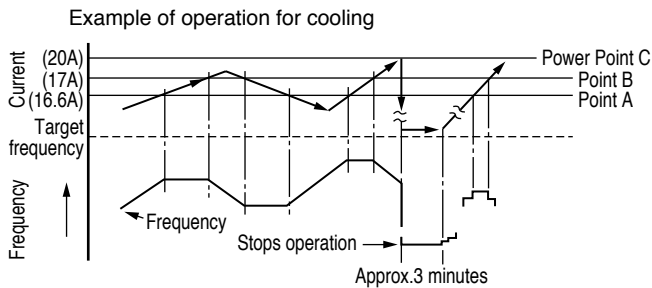

- Operates at the target frequency at Point A and below.
- Stops increases to the frequency between Points A and B.
- Reduces the frequency by 1 Hz per 0.5 seconds when Point B is exceeded.
- Stops operation, and restarts it approximately 3 minutes later, if Point C is exceeded. (May operate when sudden voltage fluctuations occur. → Indicates trouble.)

(1) Automatic frequency control

The operating frequency is reduced automatically, or operation is stopped, in order to control the operating current so that it is at or below the values shown in the table below.

	(20A)
	COOL
Point C (peak cut trip)	(20.0)
Point B (Hz reduction)	(17.0)
Point A (Hz increase prohibit)	(16.6)

(2) Current control

The operating frequency upper limits shown in the figure below are established for frequency reduction and increase-prohibit.

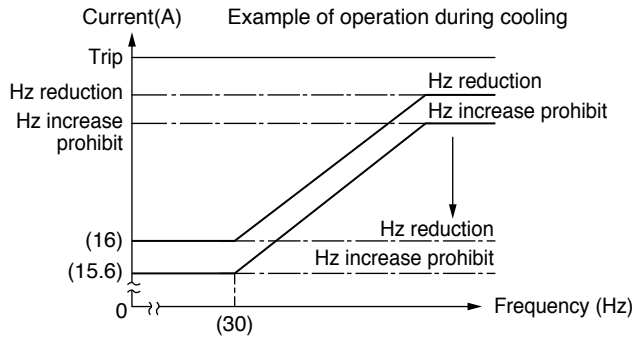

7-2-2. Low Start Current

Operation starts at (8 Hz), and the start current is less than the normal operating current. This prevents the flickering of fluorescent lights or television screens that occurs when ordinary A/C units start.

7-2-3. Compressor Temperature Control

To protect the compressor coil from overheating, the operating frequency is controlled based on the compressor discharge temperature.

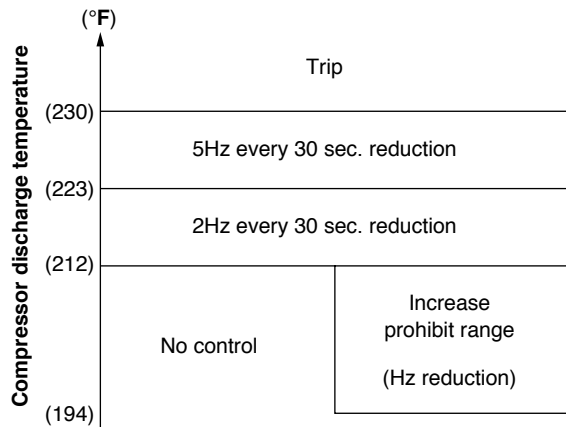

* Within the increase-prohibit range, the range changes to the Hz reduction range (2 Hz every 30 seconds) if the compressor temperature rises by 4 °F.

8. TROUBLESHOOTING

8-1. Precautions before Performing Inspection or Repair

■ **Both the indoor unit and outdoor unit include electronic control circuits.**

Be sure to pay attention to the following before inspecting or repairing the outdoor-side electronic circuits.

- High-capacity electrolytic capacitors are used inside the outdoor unit controller (inverter). They retain an electrical charge (charging voltage DC 311 V) even after the power is turned OFF, and some time is required for the charge to dissipate.

Be careful not to touch any electrified parts before the control circuit board Power Lamp (red) turns OFF.

If the outdoor control circuit board is normal, approximately 180 seconds will be required for the charge to dissipate. However, allow at least 30 minutes for the charge to dissipate if it is thought there might be trouble with the outdoor control circuit board.

For example, if the outdoor control circuit board fuse has blown, approximately 30 minutes will be required to discharge the high-capacity electrolytic capacitors.

8-2. Trouble Diagnosis by Error Monitor Lamps



WARNING

To prevent electric shock, do not inspect or repair until the Power Lamp on the P.C.Board is turned off.

8-2-1. Location of the Error Monitor Lamps

Remove the top plate of outdoor unit and the cover of Electrical Component Box.

The Power Lamp and Error Monitor Lamps are located on the P.C.Board of Electrical Component Box. (Fig.1)

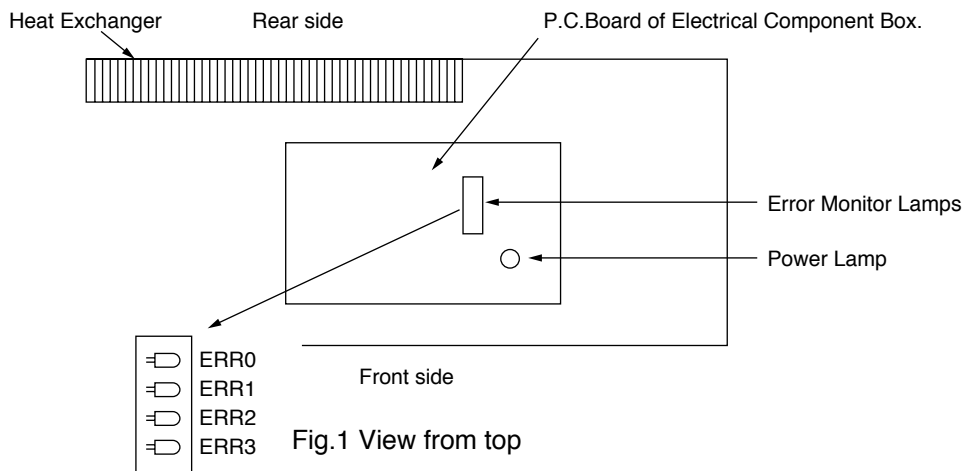

8-2-2. Display of the Error Monitor Lamps

If a protective device has activated or there is a sensor failure in the outdoor unit, the 4 error monitor lamps on the outdoor control circuit board will indicate the nature of the trouble.

○ : ON × : OFF

Error Monitor Lamp				Error Contents
ERR0	ERR1	ERR2	ERR3	
○	×	×	○	Sensor for compressor discharge temp
×	○	×	○	Sensor for heat exchange temp
○	×	×	×	Sensor for branch pipe A (Narrow tube)
×	○	×	×	Sensor for branch pipe B (Narrow tube)
○	○	×	×	Sensor for branch pipe C (Narrow tube)
×	×	○	×	Sensor for branch pipe D (Narrow tube)
○	○	×	○	Outdoor temp sensor
○	×	○	×	Sensor for branch pipe A (Wide tube)
×	○	○	×	Sensor for branch pipe B (Wide tube)
○	○	○	×	Sensor for branch pipe C (Wide tube)
×	×	×	○	Sensor for branch pipe D (Wide tube)
×	×	○	○	HIC circuit trouble (current, temp)
×	○	○	○	Actuation of comp over load relay
○	×	○	○	Actuation of freeze protection function
○	○	○	○	Outdoor unit error. Detail of error message indicate on indoor LED

8-3. Checking the Outdoor System

8-3-1. Checking the outdoor unit

No.	Work procedure	Check items (unit operation)
1	<ul style="list-style-type: none">• Apply 220 V AC between terminals L1 and L2 on the outdoor unit terminal plate.	<ul style="list-style-type: none">• The LED (red) on the control board must illuminate.
2	<ul style="list-style-type: none">• Short-circuit the T-RUN terminal to the COM terminal of TEST/T-RUN terminals.	<ul style="list-style-type: none">• The compressor and fan motor must turn ON. (They turn ON about (70) seconds later after the power is turned ON.)

NOTE If the above check items are okay, but the outdoor unit does not operate, there may be a faulty connection between the indoor unit and the outdoor unit.

8-4. Trouble Diagnosis of Each Part

8-4-1. Problems of Each Part and Inspection Points

- For details about the inspection points, refer to the Inspection Points for Each Part.

Problems Inspection points		Indoor unit				Outdoor unit					Others	No. of Inspection Points for Each part	
		Indoor unit does not operate.	Operation lamp blinking.	Operation lamp does not illuminate.	Indoor fan dose not turn.	Outdoor unit does not operate.	Outdoor fan dose not turn.	The compressor (only) does not operate.	The compressor stops on occasion.	The compressor speed does not increase.	The electric expansion valve does not operate.		Does not cool or cooling performance is inadequate.
Self-Diagnostics check			<input type="radio"/>		<input type="radio"/>	<input type="radio"/>	<input type="radio"/>	<input type="radio"/>					
Indoor unit	Indoor controller (control unit)	<input type="radio"/>	<input type="radio"/>	<input type="radio"/>	<input type="radio"/>	<input type="radio"/>							
	Indoor fan motor		<input type="radio"/>		<input type="radio"/>								
	Room temperature sensor		<input type="radio"/>										
	Heat exchanger temperature sensor		<input type="radio"/>		<input type="radio"/>								
	Inter-unit cable		<input type="radio"/>			<input type="radio"/>	<input type="radio"/>	<input type="radio"/>	<input type="radio"/>	<input type="radio"/>			
	Switch circuit board	<input type="radio"/>		<input type="radio"/>									
Outdoor unit	Outdoor control circuit board		<input type="radio"/>			<input type="radio"/>	<input type="radio"/>	<input type="radio"/>	<input type="radio"/>	<input type="radio"/>			(1)
	Diode module		<input type="radio"/>			<input type="radio"/>							
	HIC		<input type="radio"/>			<input type="radio"/>							
	Electrolytic capacitor		<input type="radio"/>			<input type="radio"/>							
	Fuse		<input type="radio"/>			<input type="radio"/>							(2)
	Compressor		<input type="radio"/>			<input type="radio"/>	<input type="radio"/>	<input type="radio"/>	<input type="radio"/>	<input type="radio"/>			(3)
	Compressor protective sensor		<input type="radio"/>			<input type="radio"/>		<input type="radio"/>	<input type="radio"/>				(4)
	Outdoor fan motor		<input type="radio"/>			<input type="radio"/>	<input type="radio"/>		<input type="radio"/>				
	Coil thermistor		<input type="radio"/>			<input type="radio"/>							(5)
	Electric expansion valve									<input type="radio"/>	<input type="radio"/>		(6)
	Branch tubing temperature sensor		<input type="radio"/>										(7)

Problems Inspection points		Indoor unit				Outdoor unit					Others	No. of Inspection Points for Each part	
		Indoor unit does not operate.	Operation lamp blinking.	Operation lamp does not illuminate.	Indoor fan dose not turn.	Outdoor unit does not operate.	Outdoor fan dose not turn.	The compressor (only) does not operate.	The compressor stops on occasion.	The compressor speed does not increase.	The electric expansion valve does not operate.		Does not cool or cooling performance is inadequate.
Others	Breaker	<input type="radio"/>				<input type="radio"/>							(8)
	Refrigerant gas pressure							<input type="radio"/>				<input type="radio"/>	(9)

8-4-2. Inspection Points for Each Part

(1) Outdoor control circuit board

Refer to 8-3-1. Checking the outdoor unit.

NOTE Do not remove or insert the outdoor control circuit board connector when power is being supplied to it.
(The controller will be damaged.)

(2) Fuse

Check it visually or the continuity with a tester.

(3) Compressor

Check for an open circuit in the compressor coil winding.

(4) Compressor protective sensor (compressor discharge temperature thermistor)

Check that the sensor is securely contained in the thermostart holder.

(5) Coil thermistor

Check that the sensor is securely contained in the thermostat holder.

(6) Electric expansion valve

- When replacing the electric expansion valve and coil, be sure to attach the connectors in the correct positions. Labels are applied to the valve body and coil, corresponding to the connector colors, to identify them.

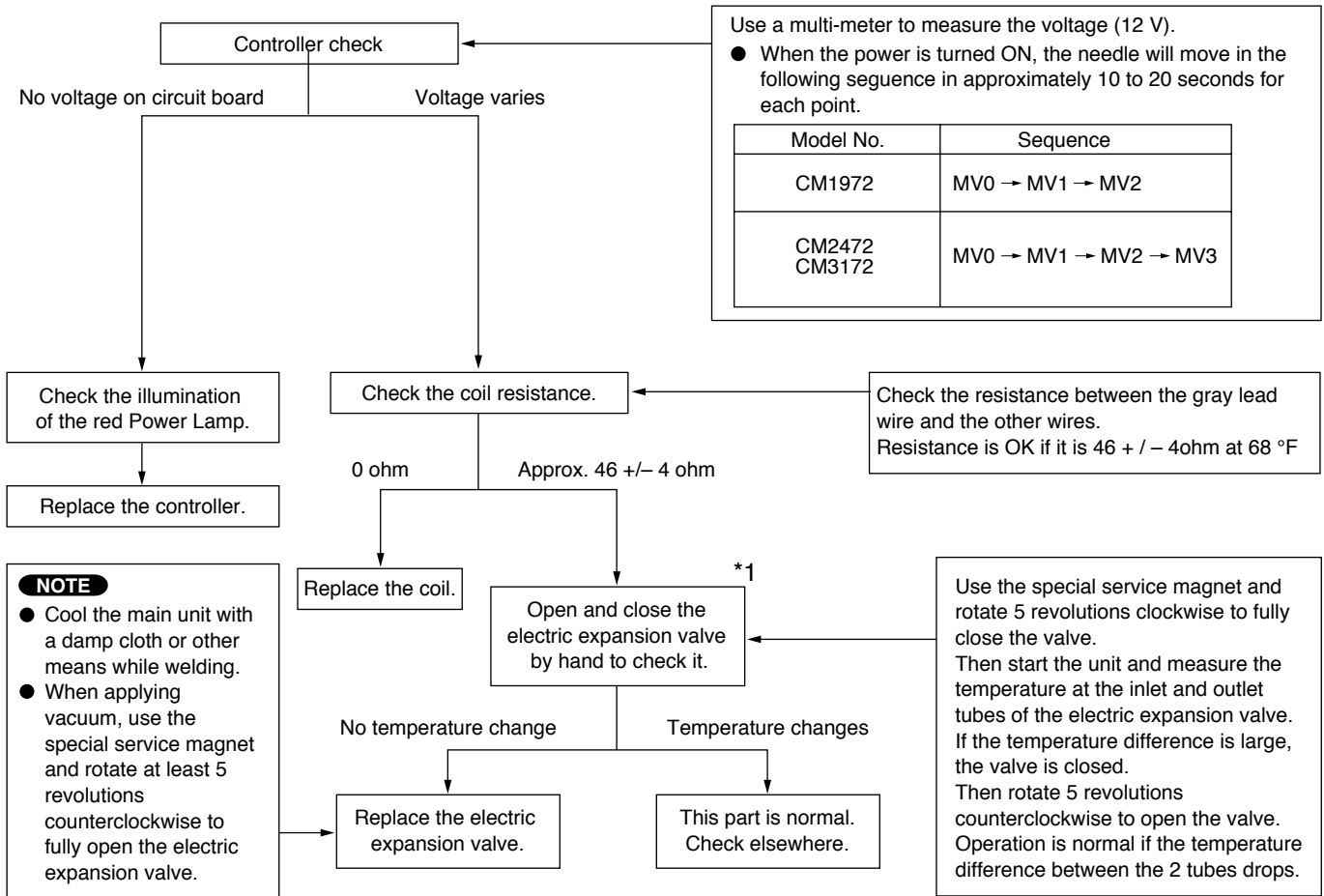

*1 If you have manually checked the electric expansion valve, be sure to reapply the outdoor power after you have replaced the wiring. (The position of the electric expansion valve will change.)

(7) Branch tubing temperature sensor

Check that the sensor is securely contained in the thermostat holder.

(8) Breaker

Check whether or not the breaker has been tripped.

- Check that the breakers and fuses used are of the specified capacity.
- Check that the breaker and its line are exclusive for A/C use.

(9) Refrigerant gas pressure

Start a COOL test run, and measure the temperatures of the A/C intake air and discharge air. Compare the values with the performance charts.

- If the values are higher than the performance charts:

Check for refrigerant shortage or blockage of the refrigerant circuit.

< Assessment of refrigerant shortage >

1. The pressure in the low-pressure section is 5 MPa or more below the value in the performance charts.
2. There is little condensation on the indoor heat exchanger, which overall appears dry.

< Distinguishing between refrigerant shortage and refrigerant circuit blockage >

If the pressure in the low-pressure section does not change when the circuit is charged 2 to 3 times with refrigerant gas (0.44 lbs each time), or if the change is small, then the problem may not be refrigerant shortage.

The problem may be a blockage of the refrigerant circuit.

1. Check that there is no internal leakage inside the 4-way valve:

At the low-pressure side tubing, check that there is no temperature difference between the intake and discharge of the 4-way valve.

2. Check that the electric expansion valve is not blocked. Check as described on the preceding page.

8-5. Trouble Diagnosis of Fan Motor

- This outdoor DC fan motor contains an internal control PCB. Therefore, it is not possible to measure the coil resistance, and the following procedure should be used to check the motor.
- Perform the trouble diagnosis by Test Run mode described on Installation Instructions of indoor unit.

Important: (A) Turn OFF the power before connecting or disconnecting the motor connectors.

(B) When performing voltage measurement at the outdoor controller connector for (3) in the table below, the DC motor will trip and voltage output will stop approximately 10 seconds after operation is started. For this reason, to measure the voltage again, first turn OFF the outdoor unit power, then, measure the voltage in Test Run mode.

[Trouble symptom 1] The fan does not stop when the outdoor unit stops. → Outdoor unit controller trouble

[Trouble symptom 2] The fan motor does not rotate when the outdoor unit is operating.

(Diagnostic procedure)

* Disconnect the motor connectors and measure the voltage at the DC motor connectors on the outdoor unit controller (3 locations).

Measurement location	Normal value
(1) Vm-Gnd: Between pin 1 and pin 4	DC 230V or more
(2) Vcc-Gnd: Between pin 5 and pin 4	DC 14V or more
(3) Vsp-Gnd: Between pin 7 and pin 4	After fluctuating 4 times between DC 1.7 to 6.1V (1 sec. ON) and DC 0 V (1 sec. OFF), the DC motor trips.

(Diagnostic results)

All of the above measured values are normal. → Fan motor trouble (Replace the motor.)

Any one of the above measured values is not normal. → Outdoor unit controller trouble (Replace the controller .)

(Reference) DC motor connector pin arrangement

- Pin 1: Vm (red)
- Pin 2: Not used
- Pin 3: Not used
- Pin 4: Gnd (blue)
- Pin 5: Vcc (brown)
- Pin 6: PG (white)
- Pin 7: Vsp (orange)

[Trouble symptom 3] Motor rotates for some time (several seconds), but then quickly stops, when the outdoor unit operates.

(There is trouble in the system that provides feedback of motor rotation speed from the motor to the outdoor unit controller.)

[Trouble symptom 4] Fan motor rotation speed does not change during outdoor unit operation.

[Trouble symptom 5] Fan motor rotation speed varies excessively during outdoor unit operation.

(Remedy for symptom 3 to 5)

It is not possible to identify whether the trouble is outdoor unit controller trouble or motor trouble.

Therefore, first replace the outdoor unit controller, then (if necessary) replace the DC motor.

9. REFRIGERANT R410A: SPECIAL PRECAUTIONS WHEN SERVICING UNIT

9-1. Characteristics of New Refrigerant R410A

9-1-1. What is New Refrigerant R410A?

R410A is a new refrigerant that contains two types of pseudo-non-azeotropic refrigerant mixture. Its refrigeration capacity and energy efficiency are about the same level as the conventional refrigerant, R22.

9-1-2. Components (mixing proportions)

HFC32 (50%) / HFC125 (50%)

9-1-3. Characteristics

- Less toxic, more chemically stable refrigerant
- The composition of refrigerant R410A changes whether it is in a gaseous phase or liquid phase. Thus, when there is a refrigerant leak the basic performance of the air conditioner may be degraded because of a change in composition of the remaining refrigerant. **Therefore, do not add new refrigerant.** Instead, recover the remaining refrigerant with the refrigerant recovery unit. Then, after evacuation, totally recharge the specified amount of refrigerant with the new refrigerant at its normal mixed composition state (in liquid phase).
- When refrigerant R410A is used, the composition will differ depending on whether it is in gaseous or liquid phase, and the basic performance of the air conditioner will be degraded if it is charged while the refrigerant is in gaseous state. **Thus, always charge the refrigerant while it is in liquid phase.**



CAUTION

Ether-type oil is used for compressor oil for R410A-type units, which is different from the mineral oil used for R22. Thus more attention to moisture prevention and faster replacement work compared with conventional models are required.

9-2. Checklist before Servicing

Use a clutch-type flare tool for R410A or the conventional flare tool. Note that sizes of the resultant flares differ between these two tools. Where a conventional flare tool is used, make sure to observe A Specification (amount of extrusion) by using the flare spacer.

Diameter of tube D	Specification A	
	Flare tool for R410A	Conventional flare tool (for R22)
Dia. 1/4" (6.35 mm)	0 to 0.0196" (0 to 0.5 mm)	0.0472" (1.2 mm)
Dia. 3/8" (9.52 mm)		
Dia. 1/2" (12.7 mm)		
Dia. 5/8" (15.88 mm)		

● Size of flare

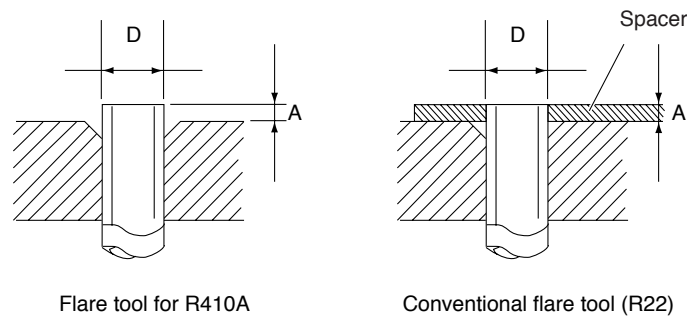

● Tubing precautions

- Refrigerant R410A is more easily affected by dust or moisture compared with R22, thus be sure to temporarily cover the ends of the tubing with caps or tape prior to installation.

Never use 0.0276" (0.7 mm)-thick copper tubing or tubing which is less than 0.0315" (0.8 mm) in thickness, since air conditioners with R410A are subject to higher pressure than those using R22 and R407C.

● No addition of compressor oil for R410A

No additional charge of compressor oil is permitted.

● No use of refrigerant other than R410A

Never use a refrigerant other than R410A.

● If refrigerant R410A is exposed to fire

Through welding, etc., toxic gas may be released when R410A refrigerant is exposed to fire. Therefore, be sure to provide ample ventilation during installation work.

● Caution in case of R410A leak

Check for possible leak points with the special leak detector for R410A. If a leak occurs inside the room, immediately provide thorough ventilation.

9-3. Tools Specifically for R410A

- For servicing, use the following tools for R410A

Tool Distinction	Tool Name
Tools specifically for R410A	<ul style="list-style-type: none"> ● Gauge manifold ● Charging hose ● Gas leak detector ● Refrigerant cylinder ● Charging cylinder ● Refrigerant recovery unit ● Vacuum pump with anti-reverse flow (*1) (Solenoid valve-installed type, which prevents oil from flowing back into the unit when the power is off, is recommended.) ● Vacuum pump (*2)...can be used if the following adapter is attached. ● Vacuum pump adapter (reverse-flow prevention adapter) (*3). (Solenoid valve-installed adapter attached to a conventional vacuum pump.) ● Electronic scale for charging refrigerant ● Flare tool
Tools which can be commonly used for R22, R407C, and R410A	<ul style="list-style-type: none"> ● Bender ● Torque wrench ● Cutter, reamer ● Welding tool, nitrogen gas cylinder



CAUTION

- The above tools specifically for R410A must not be used for R22 and R407C. Doing so will cause malfunction of the unit.
- For the above vacuum pump (*1, *2) and vacuum pump adapter (*3), those for R22-type units can be used for R410A-type. However, they must be used exclusively for R410A and never alternately with R22 and R407C.

- To prevent other refrigerants (R22, R407C) from being mistakenly charged to this unit, shape and external diameter of the service port screw has been altered.

<External diameter of service port> R410A : 5/16"
R22, R407C : 1/4"

9-4. Tubing Installation Procedures

When the tubes are connected, **always apply HAB oil on the flare portions to improve the sealing of tubing.**

The following is the **HAB oil** generally used:

Esso: ZERICE S32

NOTE For details on tubing installation procedures, refer to the installation manuals attached to the indoor unit and outdoor unit.

9-5. In Case of Compressor Malfunction



CAUTION

- Should the compressor malfunction, be sure to make the switch to a replacement compressor as quickly as possible.
- Use only the tools indicated exclusively for R410A. → See "9-3. Tools Specifically for R410A."

9-5-1. Procedure for Replacing Compressor

(1) Recovering refrigerant

- Any remaining refrigerant inside the unit should not be released to the atmosphere, but recovered using the refrigerant recovery unit for R410A.
- Do not reuse the recovered refrigerant, since it will contain impurities.

(2) Replacing Compressor

- Soon after removing seals of both discharge and suction tubes of the new compressor, replace it quickly.

(3) Checking for sealing

- Use nitrogen gas for the pressurized gas, and never use a refrigerant other than R410A. Also do not use oxygen or any flammable gas.

(4) Evacuation

- **Use a solenoid valve-installed vacuum pump** so that even if power is cut off in the middle of evacuation of air due to a power interruption, the valve will prevent the pump oil from flowing back.
- The equipment may be damaged if moisture remains in the tubing, thus carry out the evacuation thoroughly.
- When using a vacuum pump with exhaust air volume more than 0.883 cu.ft./min. and ultimate vacuum pressure rate of 50 micron Hg.

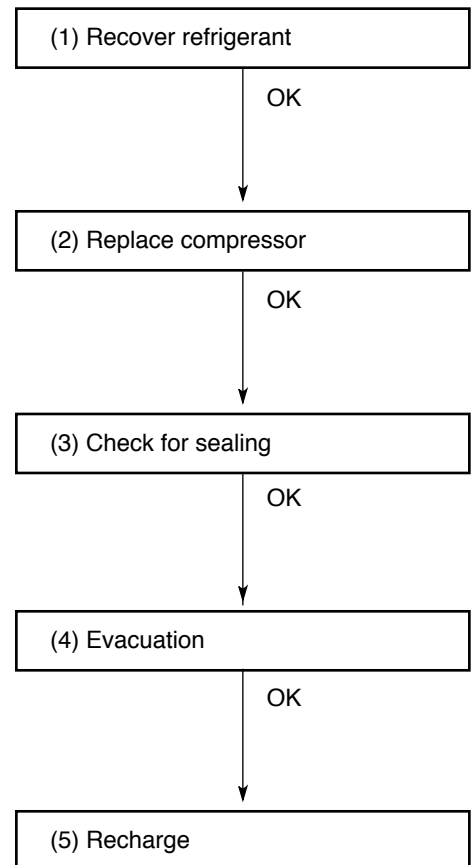

Standard time for evacuation

Length of tubing	Less than 33 ft. (10 m)	More than 33 ft. (10 m)
Evacuation time	More than 10 minutes	More than 15 minutes

(5) Recharging

- **Be sure to charge the specified amount of refrigerant in liquid state** using the service port of the wide tube service valve. The proper amount is listed on the unit's nameplate.

When the entire amount cannot be charged all at once, charge gradually while operating the unit in Cooling Operation.



CAUTION

Never charge a large amount of liquid refrigerant at once to the unit. This may cause damage to the compressor.

- When charging with a refrigerant cylinder, use an electronic scale for charging refrigerant. In this case, if the volume of refrigerant in the cylinder becomes less than 20% of the fully-charged amount, the composition of the refrigerant starts to change. Thus, **do not use the refrigerant if the amount in the charging cylinder is less than 20%.**

Also, charge the minimum necessary amount to the charging cylinder before using it to charge the air conditioning unit.

Example:

In case of charging refrigerant to a unit requiring 1.68 lb. (0.76 Kg) using a capacity of a 22 lb. (10 Kg) cylinder, the minimum necessary amount for the cylinder is:

$$1.68 + 22 \times 0.20 = 6.08 \text{ lb.}$$

$$(0.76 + 10 \times 0.20 = 2.76 \text{ Kg})$$

- **For the remaining refrigerant, refer to the instructions of the refrigerant manufacturer.**

If using a charging cylinder, transfer the specified amount of liquid refrigerant from the refrigerant cylinder to the charging cylinder.

Prepare an evacuated charging cylinder beforehand.



CAUTION

- **To prevent the composition of R410A from changing, never bleed the refrigerant gas into the atmosphere while transferring the refrigerant. (Fig. 3)**

Do not use the refrigerant if the amount in the charging cylinder is less than 20%.

Configuration and characteristics of cylinders

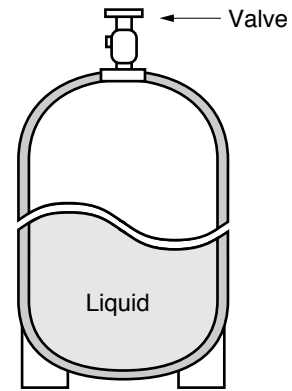

Single valve

Charge liquid refrigerant with cylinder in up-side-down position.

Fig. 1

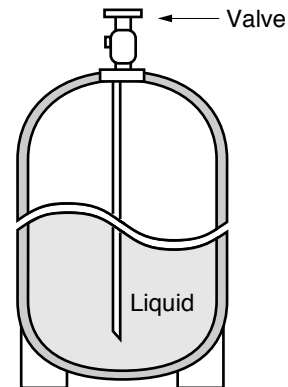

Single valve (with siphon tube)

Charge with cylinder in normal position.

Fig. 2

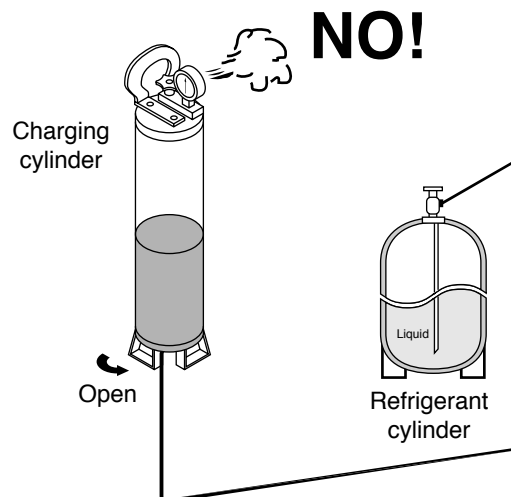

Fig. 3

9-6. In Case Refrigerant is Leaking



CAUTION

Never attempt to charge additional refrigerant when refrigerant has been leaking from the unit. Follow the procedure described below to locate points of leaks and carry out repairs, then recharge the refrigerant.

(1) Detecting Leaks

- Use the detector for R410A to locate refrigerant leak points.

(2) Recovering refrigerant

- Never release the gas to the atmosphere; recover residual refrigerant using the refrigerant recovery unit for R410A, instead.
- Do not reuse the recovered refrigerant because its composition will have been altered.

(3) Welding leaking points

- Confirm again that no residual refrigerant exists in the unit before starting welding.
- Weld securely using flux and wax for R410A.
- Prevent oxide film from forming inside the tubes utilizing substitution with nitrogen (N₂) in the refrigerant circuit of the unit. Leave ends of tubes open during welding.

(4) Checking for sealing

- Use nitrogen gas for the pressurized gas, and never use a refrigerant other than R410A. Also do not use oxygen or any flammable gas.

(5) Evacuation

- **Use a solenoid valve-installed vacuum pump** so that even if power is cut off in the middle of evacuation of air due to a power interruption, the valve will prevent the pump oil from flowing back.
- The equipment may be damaged if moisture remains in the tubing, thus carry out the evacuation thoroughly.
- When using a vacuum pump with exhaust air volume more than 0.883 cu.ft./min. and ultimate vacuum pressure rate of 50 micron Hg.

Standard time for evacuation

Length of tubing	Less than 33 ft. (10 m)	More than 33 ft. (10 m)
Evacuation time	More than 10 minutes	More than 15 minutes

(6) Recharging

- Recharge unit in the same manner explained on the previous page "(5) Recharging."

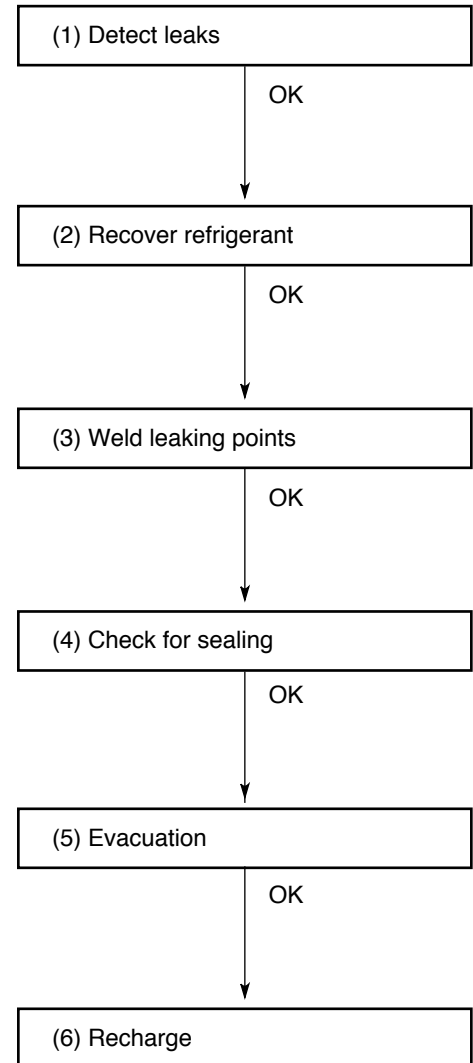

9-7. Charging Additional Refrigerant

9-7-1. When Tubes are Extended

- Observe the proper amount of refrigerant as stated in this service manual or the installation manual that came with the indoor unit. **Charge additional refrigerant in liquid state only.**



CAUTION

Never charge additional refrigerant if refrigerant is leaking from the unit. Follow instructions given in "9-6. In Case Refrigerant is Leaking" and completely carry out repairs. Only then should you recharge the refrigerant.

9-8. Retro-Fitting Existing Systems

9-8-1. Use of Existing Units

- **Never use new refrigerant R410A for existing units which use R22.** This will cause the air conditioner to operate improperly and may result in a hazardous condition.

9-8-2. Use of Existing Tubing

- If replacing an older unit that used refrigerant R22 with a R410A unit, **do not use its existing tubing.** Instead, completely new tubing must be used.

APPENDIX A INSTALLATION INSTRUCTIONS

CM1972

CM2472

CM3172

(II-852-6-4190-214-00-3)

SANYO INSTALLATION INSTRUCTIONS

– Inverter Multi Split System Air Conditioner – COOL/DRY Model

This air conditioner uses the new refrigerant R410A.

NOTE Refrigerant service valve size = 5/16"

Contents

	Page
IMPORTANT!	
Please Read Before Starting	2
1. GENERAL	3
1-1. Tools Required for Installation (not supplied)	
1-2. Accessories Supplied with Unit	
1-3. Optional Copper Tubing Kit	
1-4. Type of Copper Tube and Insulation Material	
1-5. Additional Materials Required for Installation	
2. INSTALLATION SITE SELECTION	4
2-1. Indoor Unit	
2-2. Connecting Indoor Units	
2-3. Outdoor Unit	
2-4. Baffle Plate for the Outdoor Unit (CLM models only)	
2-5. Outer Dimensions of Outdoor Unit	
2-6. Diagram of Outdoor Unit Installation	
3. INSTALLATION PROCESS	15
3-1. Embedding the Tubing and Wiring	
3-2. Use of the Flaring Method	
3-3. Flaring Procedure with a Flare Tool	
3-4. Caution before Connecting Tubes Tightly	
3-5. Tubing Connections	
3-6. Insulation of Refrigerant Tubing	
3-7. Taping the Tubes	
3-8. Finishing the Installation	
4. AIR PURGING	18
■ Air Purging with a Vacuum Pump (for Test Run)	
■ Pump Down	
5. WIRING INSTRUCTIONS	21
5-1. General Precautions on Wiring	
5-2. Recommended Wire Length and Diameter	
5-3. Wiring System Diagram	
5-4. How to Connect Wiring to the Terminal	
5-5. Wiring Instructions for the Outdoor Unit	
6. TEST RUN	25
7. CONNECTING A HOME AUTOMATION DEVICE	26
8. INSTALLATION CHECK SHEET	26

Model Combinations

Combine indoor and outdoor units only as listed below.

<u>Indoor Unit</u>	<u>Outdoor Unit</u>
KMS0772	CM1972
KMS0972	CM2472
KMS1272	CM3172
KMS1872	CLM1972
KMS2472	CLM2472
	CLM3172

Combine indoor and outdoor units only as listed in the combination tables for 3-room or 4-room outdoor unit as shown in its respective manual.

Power Source:
60 Hz, single-phase, 230 / 208 VAC

Be sure to read the yellow instruction sheet attached to the outdoor unit for models using the new refrigerant R410A.

Combination example

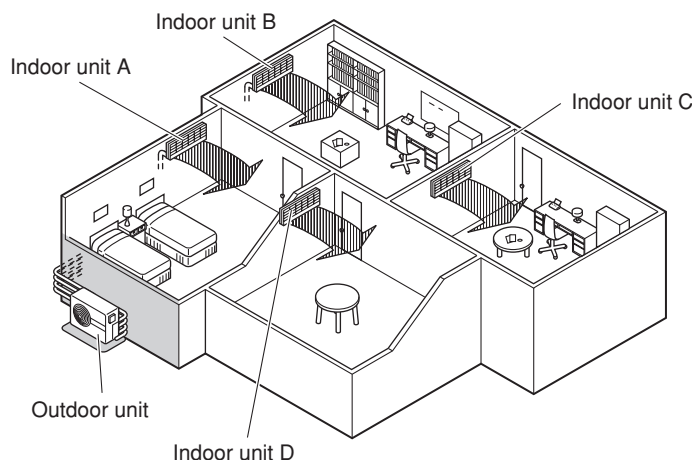

NOTE

The illustrations are based on the typical appearance of a standard model. Consequently, the shape may differ from that of the air conditioner that you are installing.

SANYO Commercial Solutions
A Division of SANYO North America Corporation
Cornerstone Business Park,
1062 Thorndale Avenue,
Bensenville, IL 60106, U.S.A.

In Canada
SANYO Canada Inc.
1-300 Applewood Crescent, Concord
Ontario, L4K 5C7, Canada

IMPORTANT!

Please Read Before Starting

This air conditioning system meets strict safety and operating standards. As the installer or service person, it is an important part of your job to install or service the system so it operates safely and efficiently.

For safe installation and trouble-free operation, you must:

- Carefully read this instruction booklet before beginning.
- Follow each installation or repair step exactly as shown.
- Observe all local, state, and national electrical codes.
- Pay close attention to all warning and caution notices given in this manual.



WARNING

This symbol refers to a hazard or unsafe practice which can result in severe personal injury or death.



CAUTION

This symbol refers to a hazard or unsafe practice which can result in personal injury or product or property damage.

If Necessary, Get Help

These instructions are all you need for most installation sites and maintenance conditions. If you require help for a special problem, contact our sales/service outlet or your certified dealer for additional instructions.

In Case of Improper Installation

The manufacturer shall in no way be responsible for improper installation or maintenance service, including failure to follow the instructions in this document.

SPECIAL PRECAUTIONS

WARNING When Wiring



ELECTRICAL SHOCK CAN CAUSE SEVERE PERSONAL INJURY OR DEATH. ONLY A QUALIFIED, EXPERIENCED ELECTRICIAN SHOULD ATTEMPT TO WIRE THIS SYSTEM.

- Do not supply power to the unit until all wiring and tubing are completed or reconnected and checked.
- Highly dangerous electrical voltages are used in this system. Carefully refer to the wiring diagram and these instructions when wiring. Improper connections and inadequate grounding can cause **accidental injury or death**.
- **Ground the unit** following local electrical codes.
- Connect all wiring tightly. Loose wiring may cause overheating at connection points and a possible fire hazard.

When Transporting

Be careful when picking up and moving the indoor and outdoor units. Get a partner to help, and bend your knees when lifting to reduce strain on your back. Sharp edges or thin aluminum fins on the air conditioner can cut your fingers.

When Installing...

...In a Ceiling or Wall

Make sure the ceiling/wall is strong enough to hold the unit's weight. It may be necessary to construct a strong wood or metal frame to provide added support.

...In a Room

Properly insulate any tubing run inside a room to prevent "sweating" that can cause dripping and water damage to walls and floors.

...In Moist or Uneven Locations

Use a raised concrete pad or concrete blocks to provide a solid, level foundation for the outdoor unit. This prevents water damage and abnormal vibration.

...In an Area with High Winds

Securely anchor the outdoor unit down with bolts and a metal frame. Provide a suitable air baffle.

...In a Snowy Area (for Heat Pump-type Systems)

Install the outdoor unit on a raised platform that is higher than drifting snow. Provide snow vents.

When Connecting Refrigerant Tubing

- Use the flare method for connecting tubing.
- Apply refrigerant lubricant to the matching surfaces of the flare and union tubes before connecting them, then tighten the nut with a torque wrench for a leak-free connection.
- Check carefully for leaks before starting the test run.

When Servicing

- Turn the power OFF at the main power box (mains) before opening the unit to check or repair electrical parts and wiring.
- Keep your fingers and clothing away from any moving parts.
- Clean up the site after you finish, remembering to check that no metal scraps or bits of wiring have been left inside the unit being serviced.

Others



CAUTION

- Ventilate any enclosed areas when installing or testing the refrigeration system. Escaped refrigerant gas, on contact with fire or heat, can produce dangerously toxic gas.
- Confirm upon completing installation that no refrigerant gas is leaking. If escaped gas comes in contact with a stove, gas water heater, electric room heater or other heat source, it can produce dangerously toxic gas.
- Do not install only a single indoor unit.

1. General

This booklet briefly outlines where and how to install the air conditioning system. Please read over the entire set of instructions for the indoor and outdoor units and make sure all accessory parts listed are with the system before beginning. If the electric wiring diagram does not appear in this manual, please check for the diagram on the indoor unit.





1-1. Tools Required for Installation (not supplied)

1. Standard screwdriver
2. Phillips head screwdriver
3. Knife or wire stripper
4. Tape measure

5. Carpenter's level
6. Sabre saw or key hole saw
7. Hacksaw
8. Core bits
9. Hammer
10. Drill
11. Tube cutter
12. Tube flaring tool
13. Torque wrench
14. Adjustable wrench
15. Reamer (for deburring)
16. Vacuum pump (For R410A)
17. Manifold valve

1-2. Accessories Supplied with Unit

Table 1

Parts	Figure	Q'ty	Parts	Figure	Q'ty	Parts	Figure	Q'ty	
Hex wrench		1	Cushion rubber		4	Reducer (1/2" x 3/8")		2472	1
								3172	2
Labels for inter-unit cable and tube		4 each	Reducer (3/8" x 1/2")		1972	1	Packed in the outdoor unit.		

1-3. Optional Copper Tubing Kit

Copper tubing for connecting the outdoor unit to the indoor unit is available in kits which contain the narrow and wide tubing, fittings and insulation. Consult your nearest sales outlet or A/C workshop.

1-4. Type of Copper Tube and Insulation Material

If you wish to purchase these materials separately from a local source, you will need:

1. Deoxidized annealed copper tube for refrigerant tubing as detailed in Table 2.
Cut each tube to the appropriate lengths 1' to 1'4" (30 cm to 40 cm) to dampen vibration between units.

2. Foamed polyethylene insulation for the specified copper tubes as required to precise length of tubing. Wall thickness of the insulation should be not less than 5/16" (8 mm).
3. Use insulated copper wire for field wiring. Wire size varies with the total length of wiring. Refer to 5. Wiring Instructions for details.



CAUTION

Check local electrical codes and regulations before obtaining wire. Also, check any specified instructions or limitations.

Table 2

Model	Narrow Tube		Wide Tube	
	Outer Dia.	Thickness	Outer Dia.	Thickness
KMS0772	1/4" (6.35 mm)	0.0314" (0.8 mm)	3/8" (9.52 mm)	0.0314" (0.8 mm)
KMS0972	1/4" (6.35 mm)	0.0314" (0.8 mm)	3/8" (9.52 mm)	0.0314" (0.8 mm)
KMS1272	1/4" (6.35 mm)	0.0314" (0.8 mm)	3/8" (9.52 mm)	0.0314" (0.8 mm)
KMS1872	1/4" (6.35 mm)	0.0314" (0.8 mm)	1/2" (12.70 mm)	0.0314" (0.8 mm)
KMS2472	1/4" (6.35 mm)	0.0314" (0.8 mm)	5/8" (15.88 mm)	0.0393" (1.0 mm)

1-5. Additional Materials Required for Installation

1. Refrigeration (armored) tape
2. Insulated staples or clamps for connecting wire
(See local codes)
3. Putty
4. Refrigeration lubricant
5. Clamps or saddles to secure refrigerant tubing

2. Installation Site Selection

2-1. Indoor Unit



WARNING

To prevent abnormal heat generation and the possibility of fire, do not place obstacles, enclosures and grilles in front of or surrounding the air conditioner in a way that may block air flow.

AVOID:

- direct sunlight.
- nearby heat sources that may affect performance of the unit.
- areas where leakage of flammable gas may be expected.
- placing or allowing any obstructions near the A/C inlet or outlet.
- installing in rooms that contain instant-on (rapid-start) fluorescent lamps. (These may prevent the A/C from receiving signals.)
- places where large amounts of oil mist exist.
- installing in locations where there are devices that generate high-frequency emissions.

DO:

- select an appropriate position from which every corner of the room can be uniformly cooled. (High on a wall is best.)
- select a location that will hold the weight of the unit.
- select a location where tubing and drain hose have the shortest run to the outside. (Fig. 1)
- allow room for operation and maintenance as well as unrestricted air flow around the unit. (Fig. 2)
- install the unit within the maximum elevation difference (H1, H2, H3, H4) above or below the outdoor unit and within a total tubing length (L1+L2+L3, L1+L2+L3+L4) from the outdoor unit as detailed in Table 3 and Fig. 3a.

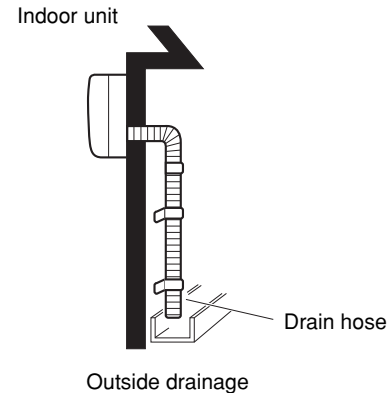
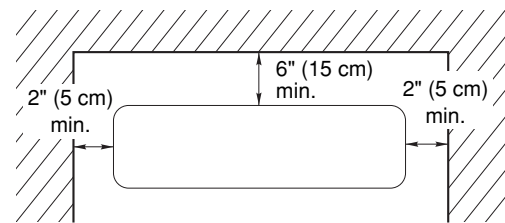

Fig. 1



Front View

Fig. 2

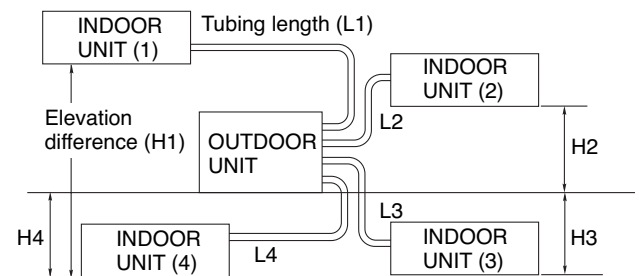

Fig. 3a



CAUTION

For stable operation of the air conditioner, do not install wall-mounted type indoor units less than 5' (1.5 m) from floor level.

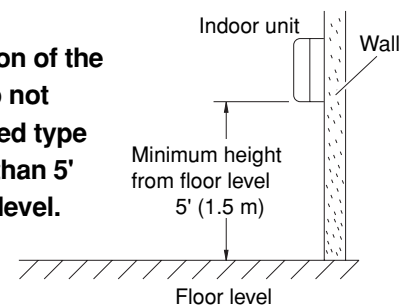

Fig. 3b

- Install the indoor unit more than 3.3' (1 m) away from any antenna or power lines or connecting wires used for television, radio, telephone, security system, or intercom. Electrical noise from any of these sources may affect operation.
- install in a sturdy manner to avoid increased operating noise.

Table 3

Model	Max. Allowable Tubing Length per unit (ft.)	Max. Allowable Total Tubing Length at shipment (L1+L2+L3) or (L1+L2+L3+L4) (ft.)	Limit of Total Tubing Length (L1+L2+L3) or (L1+L2+L3+L4) (ft.)	Limit of Elevation Difference (H1, H2, H3, H4) (ft.)	Required Amount of Additional Refrigerant (oz./ft.)*
CM1972/CLM1972	82	150 (L1+L2+L3)	150 (L1+L2+L3)	50	—
CM2472/CLM2472	82	150 (L1+L2+L3+L4)	200 (L1+L2+L3+L4)	50	0.22
CM3172/CLM3172	100	150 (L1+L2+L3+L4)	230 (L1+L2+L3+L4)	50	0.22

* If total tubing length becomes 150 to 200 ft. (Max.) or 150 to 230 ft. (Max.), charge additional refrigerant (R410A) by 0.22 oz./ft. No additional charge of compressor oil is necessary. For more detailed charging information, refer to the Technical & Service Manual.

2-2. Connecting Indoor Units

(1) Connecting indoor unit for CM1972/CLM1972

(A)

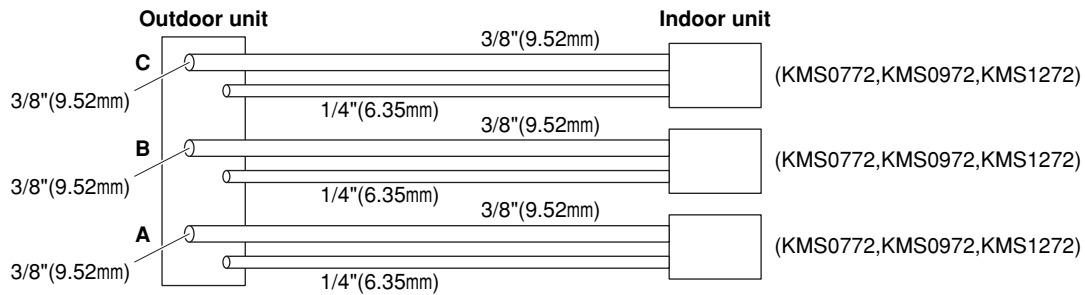

Fig. 4a

(B)

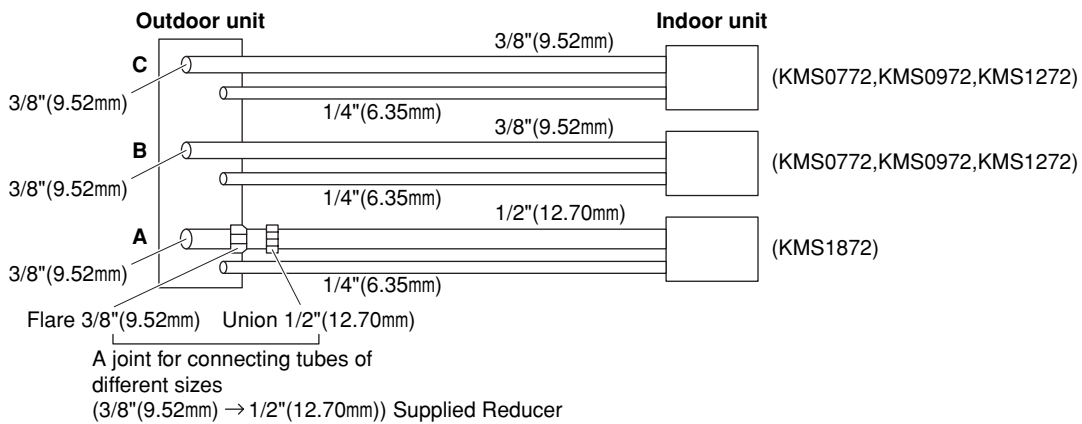

Fig. 4b

(2) Connecting indoor unit for CM2472/CLM2472

(A)

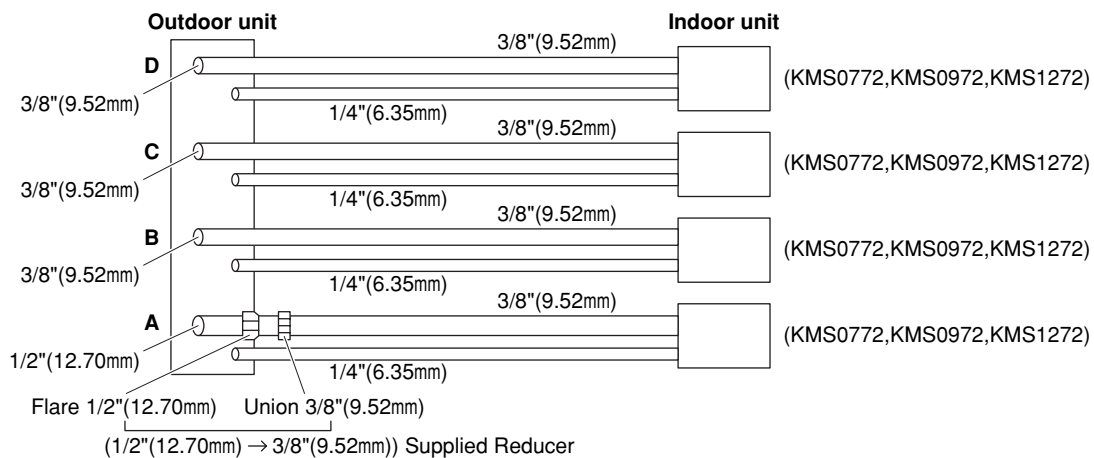

Fig. 4c

(B)

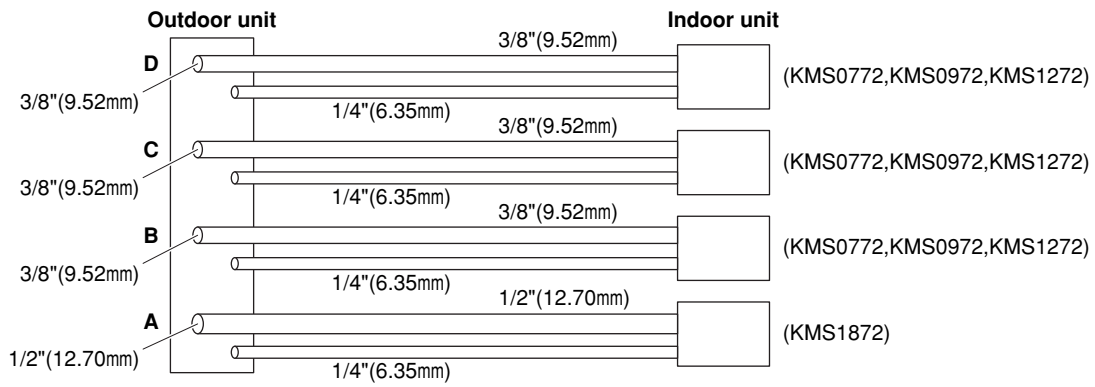

Fig. 4d

(C)

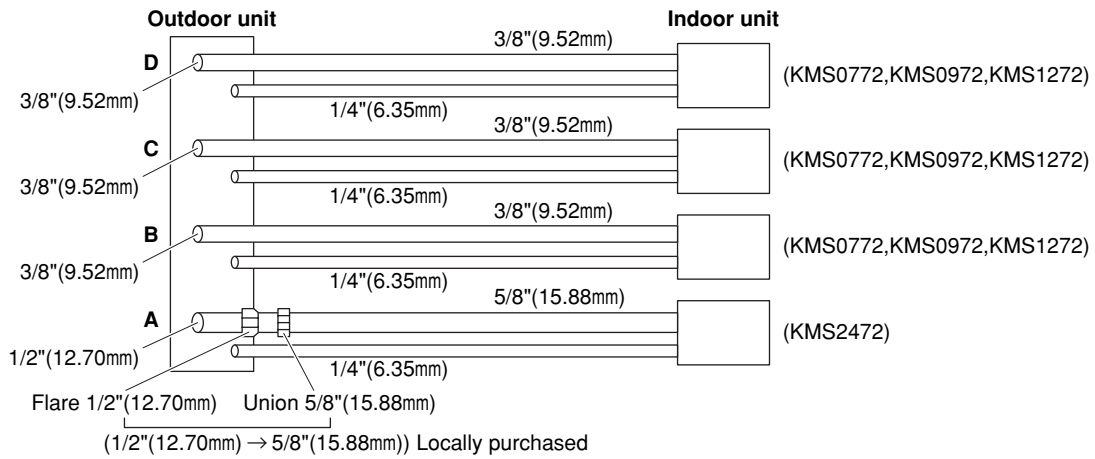

Fig. 4e

(D)

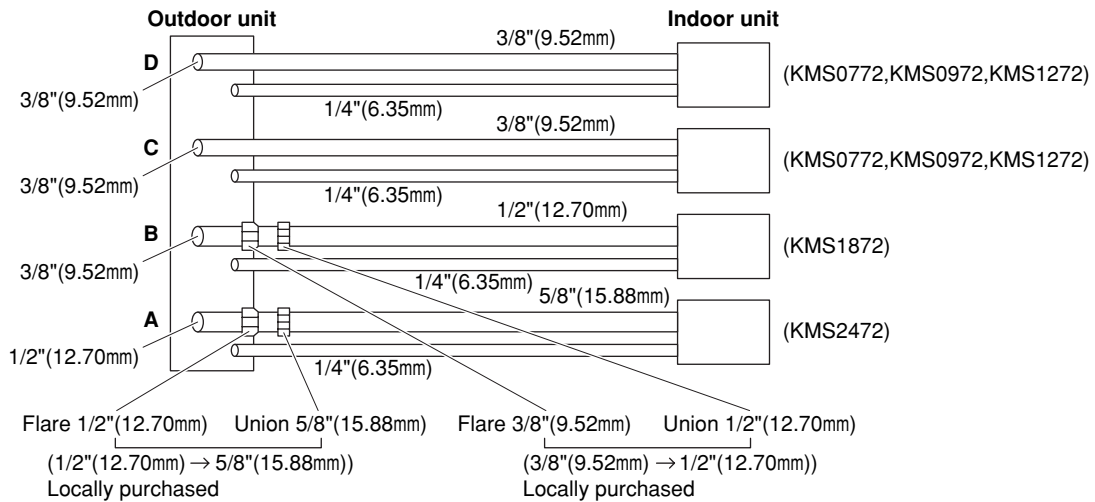

Fig. 4f

(3) Connecting indoor unit for CM3172/CLM3172

(A)

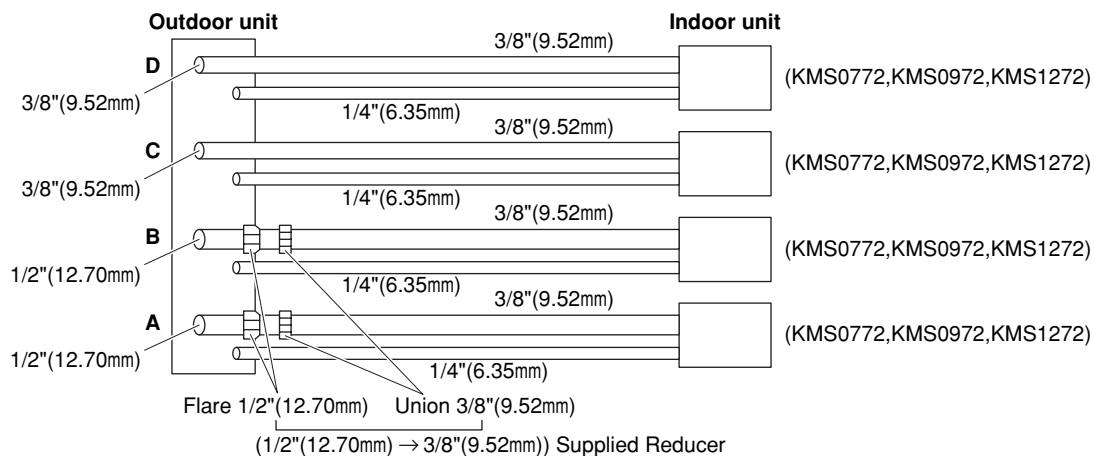

Fig. 4g

(B)

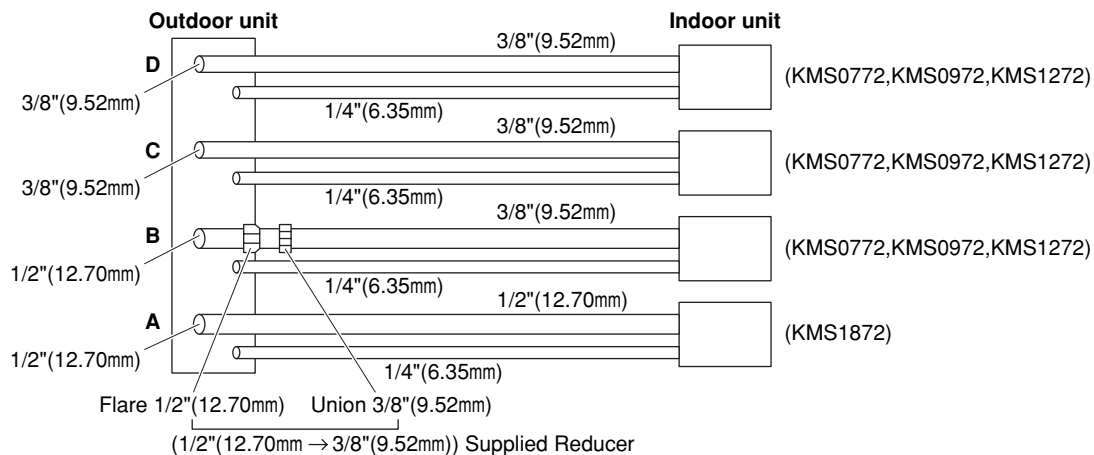

Fig. 4h

(C)

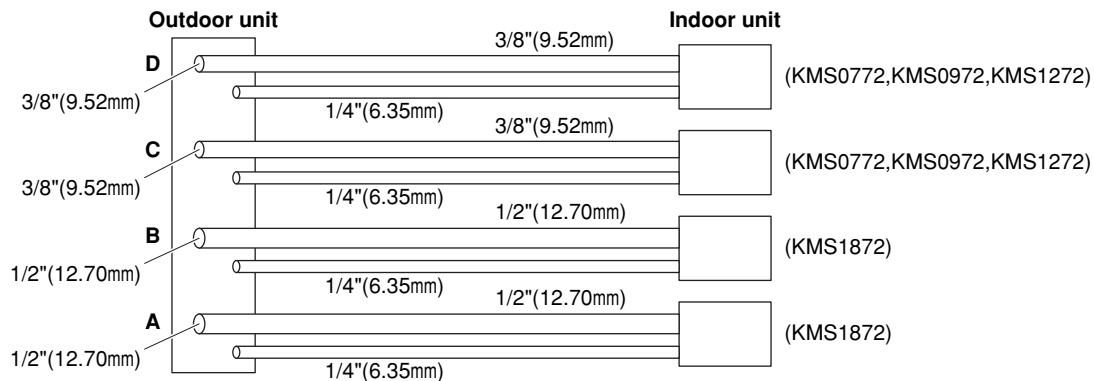

Fig. 4i

(D)

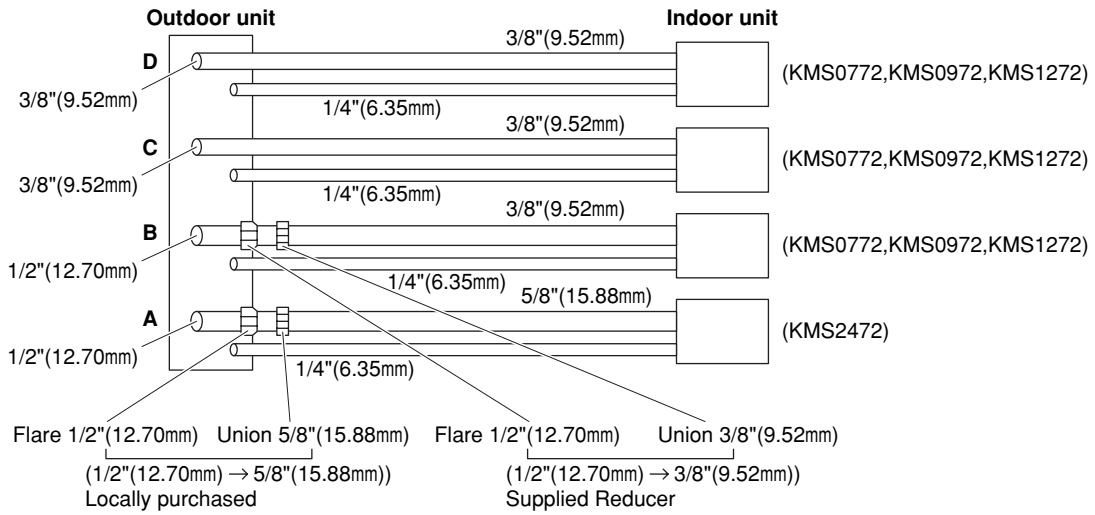

Fig. 4j

(E)

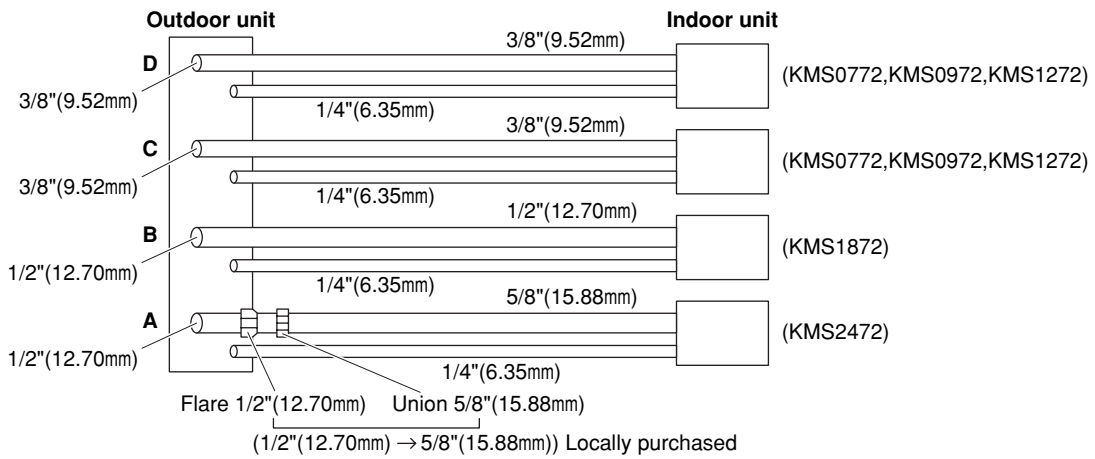

Fig. 4k

2-3. Outdoor Unit

AVOID:

- heat sources, exhaust fans, etc. (Fig. 5a)
- damp, humid or uneven locations.

DO:

- choose a place as cool as possible.
- choose a place that is well ventilated.
- allow enough room around the unit for air intake/exhaust and possible maintenance. (Fig. 5b)
- provide a solid base (level concrete pad, concrete block, 6" × 1'4" (15 × 40 cm) beams or equal), a minimum of 6" (15 cm) above ground level to reduce humidity and protect the unit against possible water damage and decreased service life. (Figs. 5c and 5d)



CAUTION

A solid base must not cover the hole of the bottom plate.

- Install cushion rubber under unit's feet to reduce vibration and noise. (Fig. 5e)
- use lug bolts or equal to bolt down unit, reducing vibration and noise.
- Install in a location where no antenna of a television or radio exists within 10' (3 m).

2-4. Baffle Plate for the Outdoor Unit (CLM models only)

NOTE

It is recommended to use baffle plates for models CLM1972, CLM2472 and CLM3172. The baffle plates are not normally required for the other models.

When the outdoor unit is installed in a position exposed to strong wind (such as seasonal winds with low air temperature in winter), baffle plates must be installed on the outdoor unit. (Fig. 5f)

This unit is designed so that the fan of the outdoor unit runs at low speed when the air conditioner is operated at low outdoor air temperatures. When the outdoor unit is exposed to strong wind, the system pressure drops because of the freeze protector.

Install a pair of windbaffle plates at the front and back of the outdoor unit if it will be subject to strong wind during the winter. (Figs. 5f, 5g, 5h, 5i, and 5j)

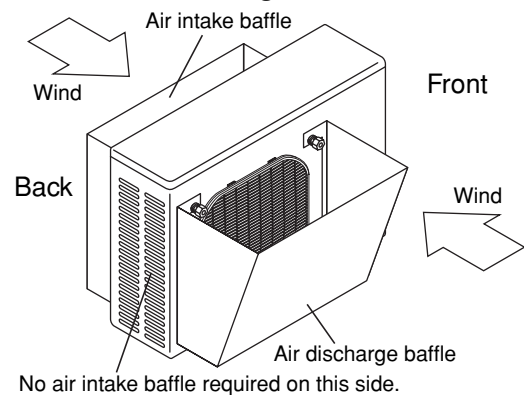
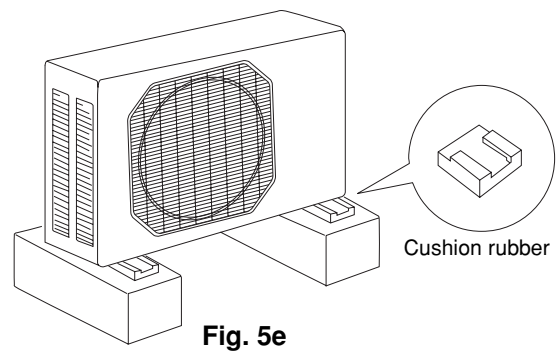
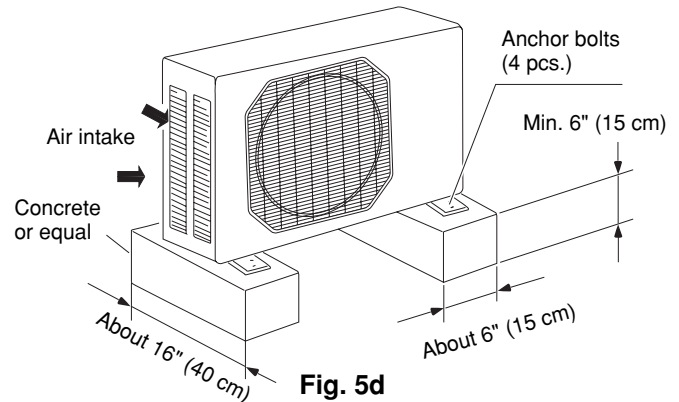
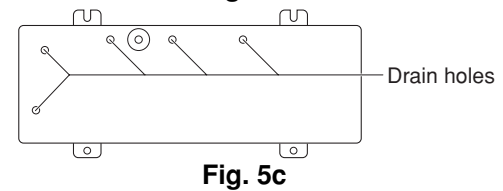
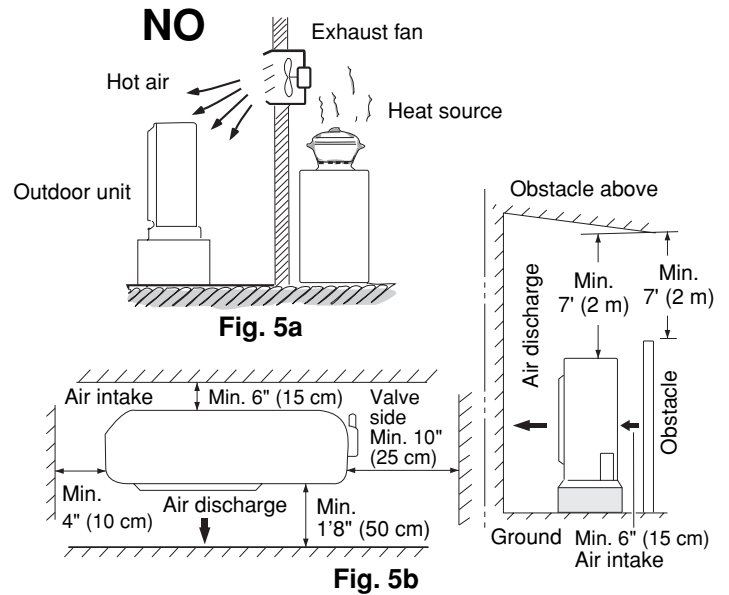

(1) Recommended dimensions of the baffle plates

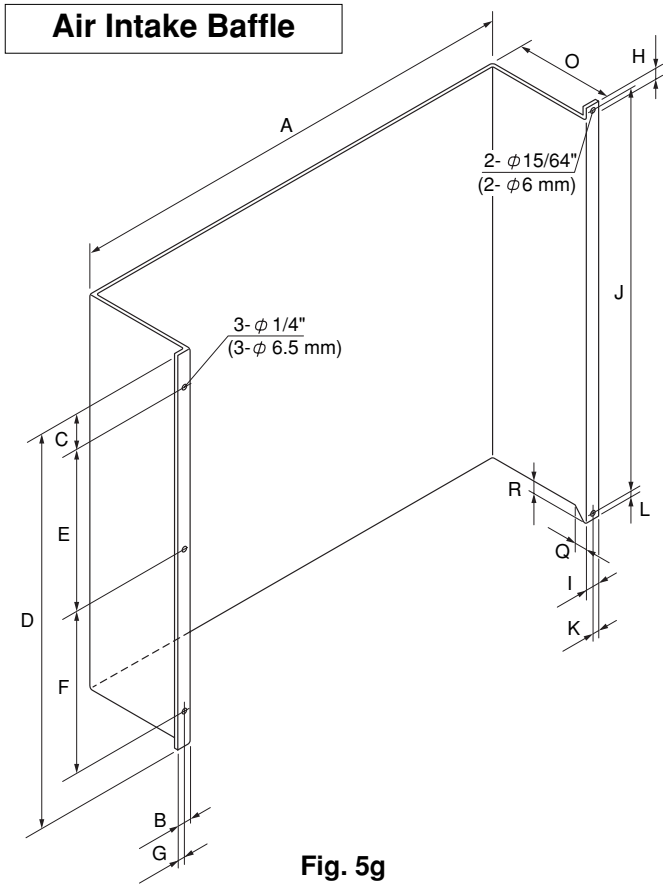

Fig. 5g

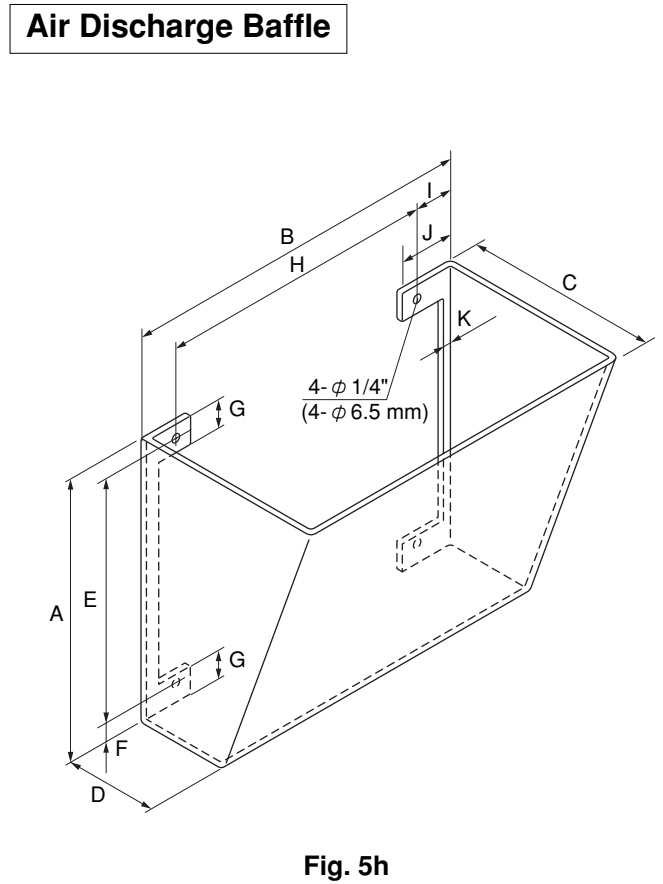

Fig. 5h

For Air Intake

Dimensions		A	B	C	D	E	F	G	H	I	J	K	L	O	Q	R
Model	(inch)	25-3/16	25/32	1-31/32	25	10-5/8	10-5/8	25/64	25/32	19/32	25-7/8	19/64	25/64	5-29/32	25/32	25/32
	(mm)	640	20	50	635	270	270	10	20	15	657	7.5	10	150	20	20
CLM1972, CLM2472	(inch)	25-3/16	25/32	1-3/8	30-29/32	13-25/32	13-25/32	25/64	25/32	19/32	31-25/32	19/64	25/64	5-29/32	25/32	25/32
	(mm)	640	20	35	785	350	350	10	20	15	807	7.5	10	150	20	20

For Air Discharge

Dimensions		A	B	C	D	E	F	G	H	I	J	K
Model	(inch)	22-1/16	23-1/32	13-25/32	5-29/32	19-9/32	1-3/8	2-5/32	18-5/16	2-3/8	3-11/32	31/32
	(mm)	560	585	350	150	490	35	55	465	60	85	25

Material to be used: Metal plate with corrosion protection treatment
 Plate thickness: 0.0394 to 0.0472" (1.0 to 1.2 mm)

(2) Parts required (field supply except for screws)

Air Intake Baffle

Item	Q'ty	Remarks
Baffle plate	1	
Screw 5/32 × 15/32" (4 × 12 mm) tapping	2	Attached to outdoor unit
Bolt 15/64 × 19/32 – 25/32" (M6 × 15 – 20 mm)	3	
Nut 15/64" (M6)	3	
Washer	3	
Spring washer	3	

Air Discharge Baffle

Item	Q'ty	Remarks
Baffle plate	1	
Bolt 15/64 × 13/32 – 19/32" (M6 × 10 – 15 mm)	4	
Nut 15/64" (M6)	4	
Washer	4	
Spring washer	4	

(3) Installation procedure

1. Air Intake Baffle

(1) Left side

1. Remove the top panel from the unit.
2. Remove the panel side L, and drill 3 holes of $\varnothing 1/4$ inch (6.5 mm) at the prescribed position.
3. Install the windbaffle on the unit using field supply bolts and nuts.
4. Recommended bolts to be used are 15/64" (M6 ISO standard), and the recommended length of the bolts is between 19/32 – 25/32 inch (15 – 20 mm).
5. Use washers and spring washers to tightly fasten the windbaffle to the unit.

(2) Right side

1. Remove the top panel from the unit.
2. Use 2 preholes on the panel side R to install the baffle plate.
3. Remove the panel side R from the unit by removing the screws. These screws are used in step 4 below.
4. Put (sandwich) the windbaffle between the unit and the panel side R, then install the windbaffle on the unit using the above screws. Be careful not to damage the screw holes.

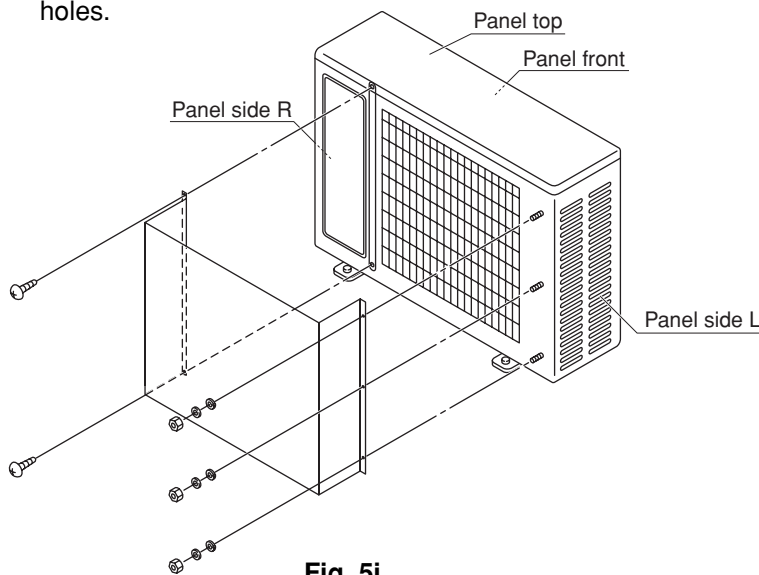

Fig. 5i

2. Air Discharge Baffle

1. Remove the panels front, top, side L and R from the unit and drill 4 holes of $\varnothing 1/4$ inch (6.5 mm) at the prescribed positions.
2. Install the windbaffle on the unit using field supply bolts and nuts.
3. Recommended bolts to be used are 15/64" (M6 ISO standard), and the recommended length of the bolts is between 13/32 – 19/32 inch (10 – 15 mm).
4. Use washers and spring washers to tightly fasten the windbaffle to the unit.

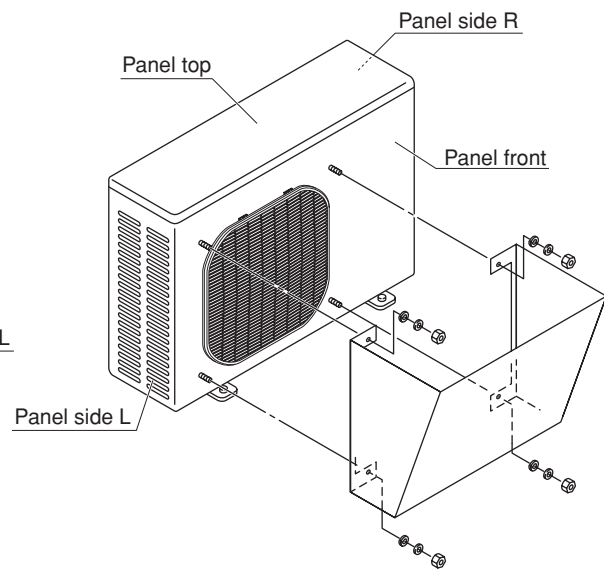

Fig. 5j

NOTE

- In order to prevent contact of the bolts and heat exchanger and other parts inside the unit, install the windbaffle using bolts from inside the unit and fasten the bolts with nuts from outside the unit.
- When the windbaffle is installed on the unit, the unit has higher wind resistance. In order to prevent the unit from falling over, anchor the legs of the unit using anchor bolts (or similar method).

(4) Precautions for installation

1. Be sure not to damage painted surfaces.
2. Finish the edges of the windbaffle to avoid cuts or injury.
3. Drilling of holes must be carefully done so that no damage is caused to external or internal parts of the unit. Particular care must be taken that drill chips do not drop into the unit.

2-5. Outer Dimensions of Outdoor Unit

(1) CM1972/CLM1972

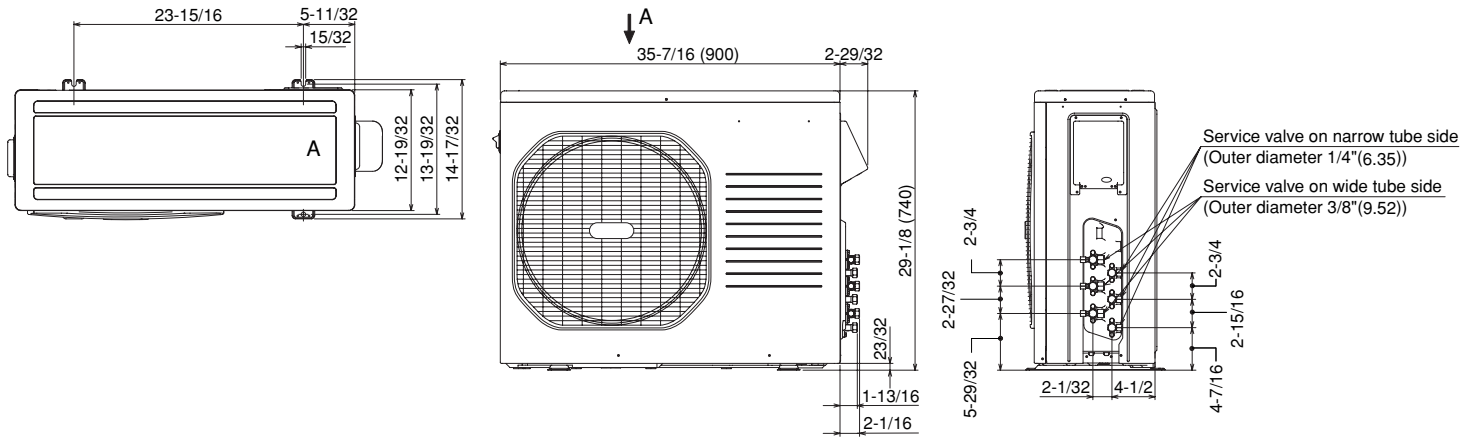

Fig. 6a

(2) CM2472/CLM2472

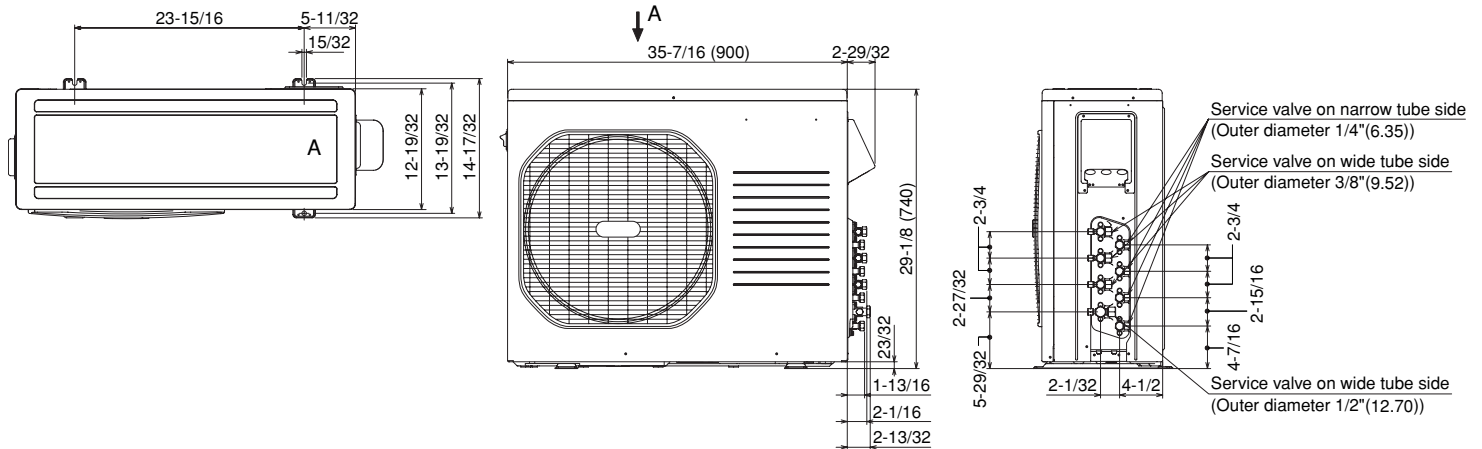

Fig. 6b

(3) CM3172/CLM3172

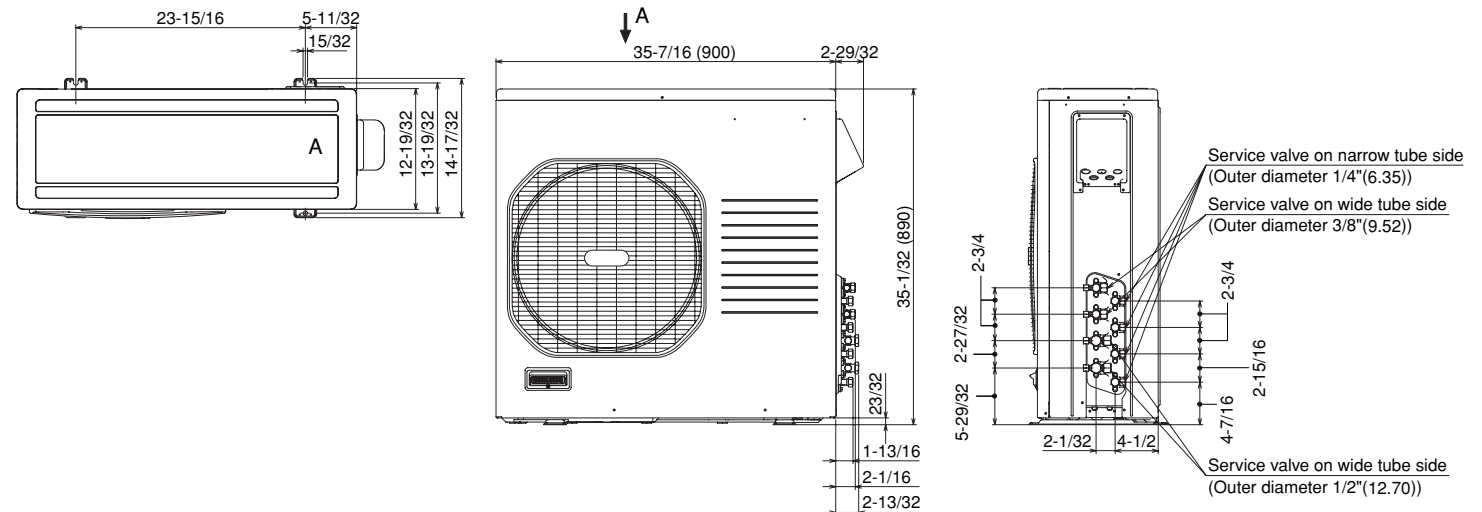

Fig. 6c

unit: inch (mm)

2-6. Diagram of Outdoor Unit Installation

Never install only a single indoor unit.

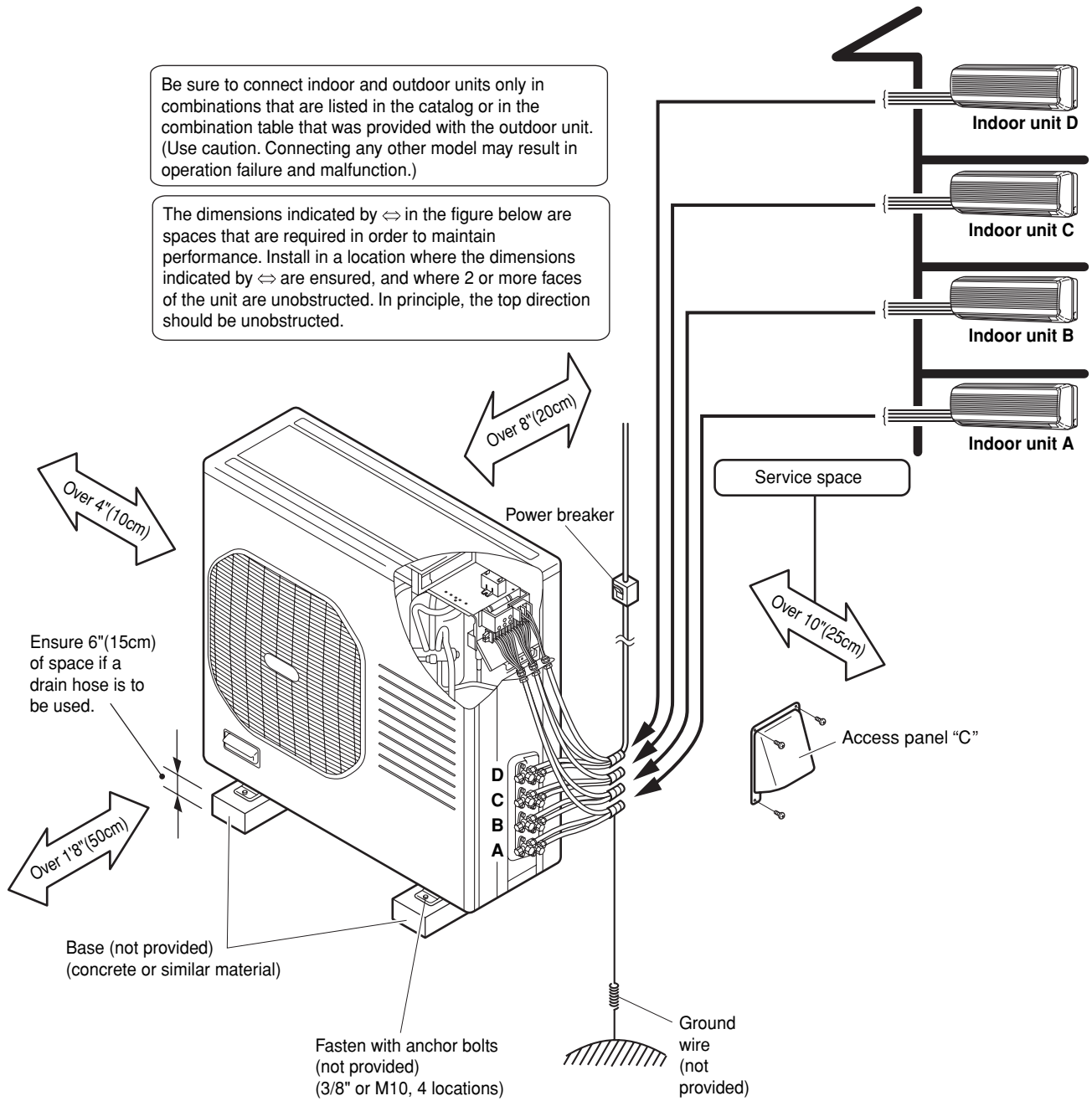

Fig. 7

3. Installation Process

3-1. Embedding the Tubing and Wiring

- Do not connect tubes to locations that are embedded.
- Be sure to bind refrigerant tubing and inter-unit cables together with vinyl tape.
- The power cable must be obtained on-site.
(#12: Less than 85 ft.)
... AWG (American Wire Gauge)
- Be sure to apply the provided labels to both ends of the inter-unit cables to prevent miswiring.
- Securely seal the end of embedded tubing with vinyl tape in order to prevent dirt or moisture entry.
- In order to prevent insulation breakdown and ground faults, do not allow the wire ends to contact rainwater, or be subject to dew condensation.

3-2. Use of the Flaring Method

Many of the conventional split system air conditioners employ the flaring method to connect refrigerant tubes which run between indoor and outdoor units. In this method, the copper tubes are flared at each end and connected with flare nuts.

3-3. Flaring Procedure with a Flare Tool

- (1) Cut the copper tube to the required length with a tube cutter. It is recommended to cut approx. 12" to 20" (30 to 50 cm) longer than the tubing length you estimate.
- (2) Remove burrs at the end of the copper tube with a tube reamer or file. This process is important and should be done carefully to make a good flare. (Fig. 8)

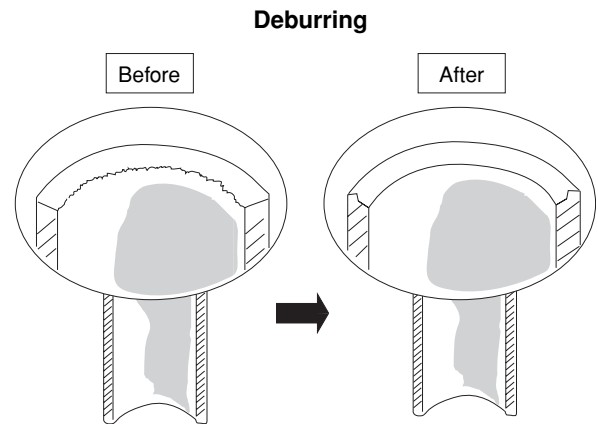

Fig. 8

NOTE

When reaming, hold the tube end downward and be sure that no copper scraps fall into the tube. (Fig. 9)

(3) Remove the flare nut from the unit and be sure to mount it on the copper tube.

(4) Make a flare at the end of copper tube with a flare tool.* (Figs. 10 and 11)

(*Use "RIGID" or equivalent.)

NOTE

A good flare should have the following characteristics:

- inside surface is glossy and smooth.
- edge is smooth.
- tapered sides are of uniform length.

3-4. Caution before Connecting Tubes Tightly

a) Be sure to apply a sealing cap or water-proof tape to prevent dust or water from getting into the tubes before they are used.

b) Be sure to apply refrigerant lubricant to the matching surfaces of the flare and union before connecting them together. This is effective for reducing gas leaks. (Fig. 12)

c) For proper connection, align the union tube and flare tube straight with each other, then screw in the flare nut lightly at first to obtain a smooth match. (Fig. 13)

3-5. Tubing Connections

a) Temporary connection:
Screw in 3 – 5 rotations by hand. (Fig.14)

b) To fasten the flare nuts, apply specified torque as:

Table 4

Tube Dia.	Tightening Torque
1/4" (6.35 mm)	Approx. 120 – 160 lbs·in (140 – 180 kgf·cm)
3/8" (9.52 mm)	Approx. 300 – 360 lbs·in (340 – 420 kgf·cm)
1/2" (12.70 mm)	Approx. 430 – 540 lbs·in (490 – 610 kgf·cm)
5/8" (15.88 mm)	Approx. 590 – 710 lbs·in (680 – 820 kgf·cm)

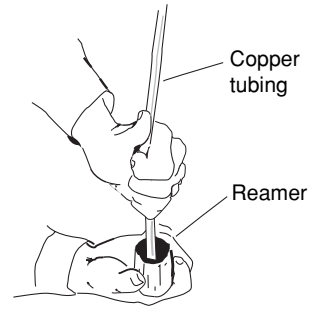
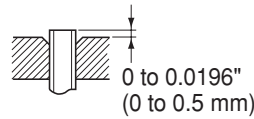
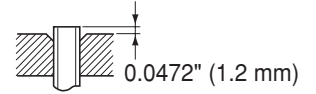

Fig. 9

If the special R410A flare tool is used:



If the previous flare tool (clutch-type) is used:



Adjust so that the amount of tube protrusion is as shown in the figure.

Fig. 10

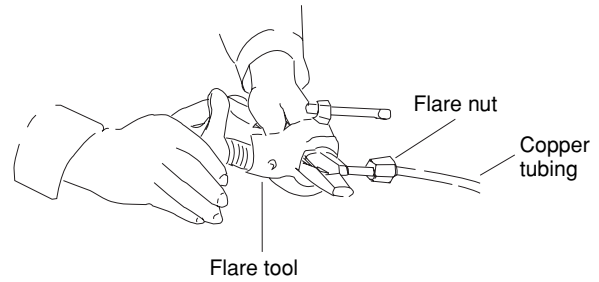

Fig. 11

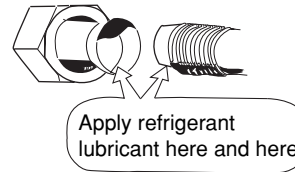

Fig. 12

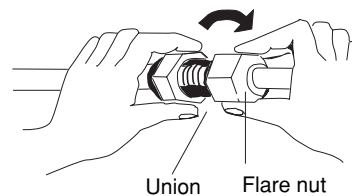

Fig. 13



Service valve on narrow tube side

Service valve on wide tube side

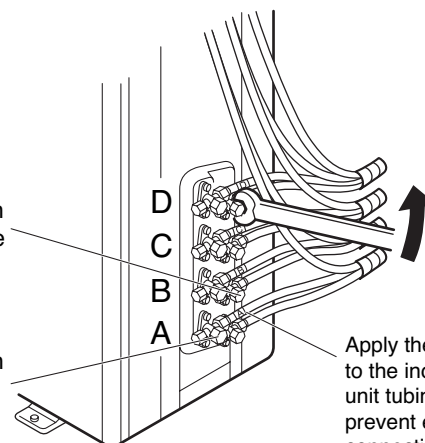
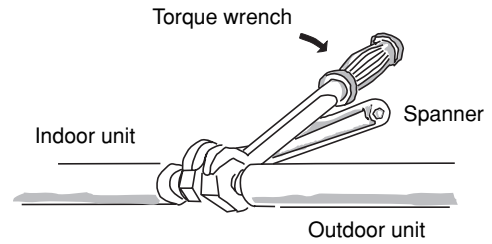

Fig. 14

**CAUTION**

Be sure to match refrigerant tubing and electric wiring between indoor and outdoor units. For more details, refer to "Tubing Check Control" in the Technical & Service Manual.

**Fig. 15****3-6. Insulation of Refrigerant Tubing****IMPORTANT**

To prevent heat loss and wet floors due to dripping of condensation, **both tubes must be well insulated with a proper insulation material.**

The thickness of the insulation should be a minimum 5/16" (8 mm). (Fig. 17)

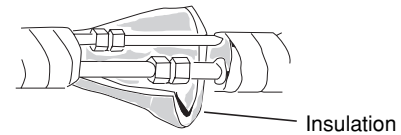
**Fig. 16****3-7. Taping the Tubes****CAUTION**

After a tube has been insulated, never try to bend it into a narrow curve, as this may cause the tube to break or crack.

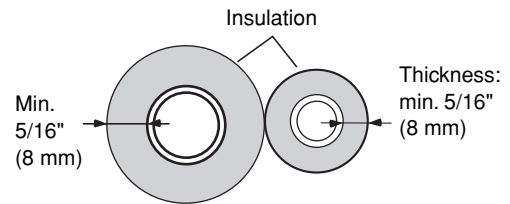
**Fig. 17**

- (1) At this time, the 2 refrigerant tubes (and electrical wire if local codes permit) should be taped together with armoring tape. The drain hose may also be included and taped together as 1 bundle with the tubing.
- (2) Wrap the armoring tape from the bottom of the outdoor unit to the top of the tubing where it enters the wall. As you wrap the tubing, overlap half of each previous tape turn. (Fig. 18)
- (3) Clamp the tubing bundle to wall, using 1 clamp approx. every 47" (120 cm).

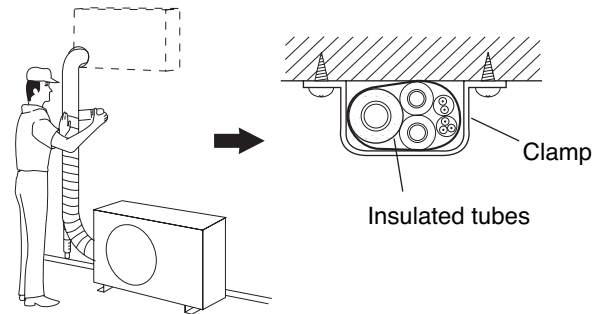
**Fig. 18****NOTE**

Do not wind the armoring tape too tightly, since this will decrease the heat insulation effect. Also, be sure the condensation drain hose splits away from the bundle and drips clear of the unit and the tubing.

3-8. Finishing the Installation

After finishing insulating and taping over the tubing, use sealing putty to seal off the hole in the wall to prevent rain and draft from entering. (Fig. 19)

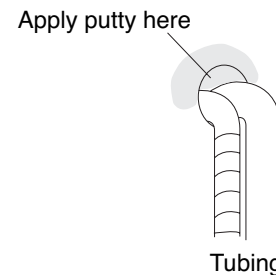
**Fig. 19**

4. Air Purging

Air and moisture remaining in the refrigerant system have undesirable effects as indicated below. Therefore, they must be purged completely.

- pressure in the system rises
- operating current rises
- cooling efficiency drops
- moisture in the air may freeze and block capillary tubing
- water may lead to corrosion of parts in the refrigerant system

■ Air Purging with a Vacuum Pump (for Test Run)

- In order to protect the earth's environment, be sure to use a vacuum pump to perform the air purge.
(Never perform an air purge by using the refrigerant gas cylinder or other external gas, or by using the gas inside the outdoor unit.)



CAUTION

In order to prevent charging errors with A/C that uses R410A, the screw diameter at the service valve charging port has been changed. When recharging or performing other servicing, use the special charging hose and manifold gauge.

Perform the air purge for tubes A, B, C, and D. Use the same procedures for all tubes.

- (1) Check that each tube (both narrow and wide tubes) between the indoor and outdoor units have been properly connected and all wiring for the test run has been completed. Note that both narrow and wide tube service valves on the outdoor unit are kept closed at this stage.
- (2) Using an adjustable wrench or box wrench, remove the valve caps from the service valve on both narrow and wide tubes.
- (3) Connect a vacuum pump and a manifold valve (with pressure gauges) to the service port on the wide tube service valve. (Fig. 20).



CAUTION

Before using the vacuum pump adapter, read the vacuum pump adapter manual, and use the adapter correctly.



CAUTION

Be sure to use a manifold valve for air purging. If it is not available, use a stop valve for this purpose. The "Hi" knob of the manifold valve must always be kept closed.

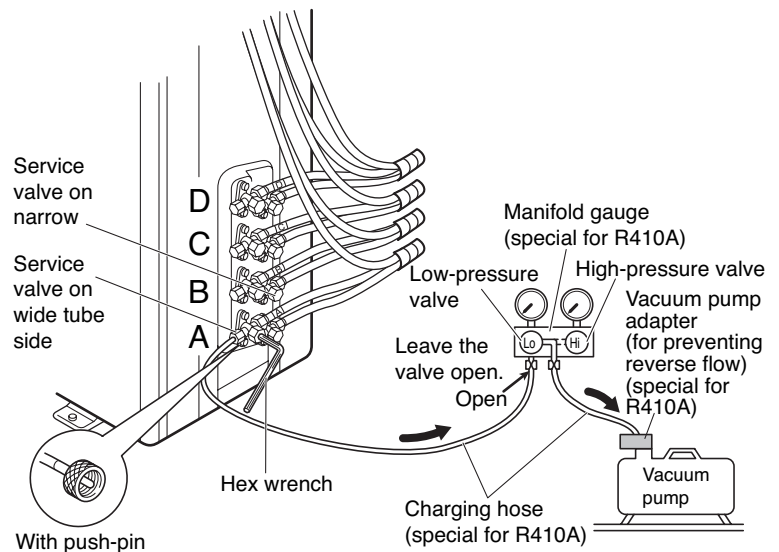
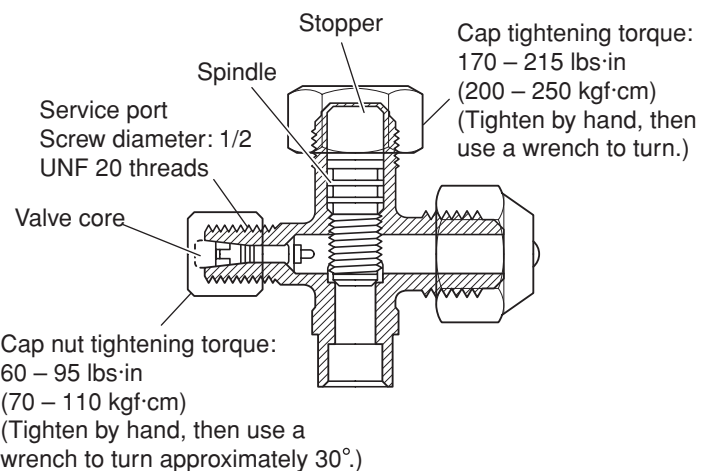

Fig. 20



<Structure of service valve on wide tube side>

NOTE

External diameter of service port R410A: 5/16"

Fig. 21

- When using a hex wrench to open the spindle, an extremely small amount of refrigerant may leak. This does not indicate a problem.
- Use a hex wrench of a type to which force can be easily applied.

- (4) With the “Lo” knob of the manifold valve open and high-pressure valve (“Hi”) closed completely, run the vacuum pump. Run the pump until the pressure is -101 kPa (-76 cmHg). The operation time for the vacuum pump varies with tubing length and the capacity of the pump. The following table shows the amount of time required for evacuation:

Table 5

Required time for evacuation when capacity of 100 liter/h vacuum pump is used
20 min. or more

NOTE

The required time in the above table is calculated based on the assumption that the ideal (or target) vacuum condition is around 10 mmHg abs.

- (5) With the vacuum pump still running, close the “Lo” knob of the manifold valve. Then stop the vacuum pump. Fully close the low-pressure valve and stop the vacuum pump. (Wait 1 – 2 minutes and check that the manifold gauge pointer does not return. If it does return, find and repair the leak, then apply the vacuum again.)
- (6) With a hex wrench, turn the valve stem on the narrow tube service valve counter-clockwise by 90 degrees ($1/4$ turn) for 10 seconds, and then turn the stem clockwise to close it again.



CAUTION

Be sure to completely insert the hex wrench before attempting to turn the valve.

- (7) With a standard screwdriver, turn the wide tube service valve stem counterclockwise to fully open the valve.
- (8) Turn the narrow tube service valve stem counterclockwise to fully open the valve.
- (9) Loosen the vacuum hose connected to the wide tube service port slightly to release the pressure. Then, remove the hose.
- (10) Leak test all joints at the tubing (both indoor and outdoors) with liquid soap. Bubbles indicate a leak. Be sure to wipe off the soap with a clean cloth.



CAUTION

If a CFC gas detector is used, use a special detector for HFC refrigerant (such as R410 and R134a).

- (11) Replace the flare nut on the wide tube service port and fasten the flare nut securely with an adjustable wrench or box wrench. Next, mount the valve cap and tighten it with a torque wrench (the cap needs to be tightened with the torque of 180 lbs-in (200 kgf·cm)). This process is very important to prevent gas from leaking from the system.
- (12) Test run the air conditioner. (See page 25.)
- (13) While the air conditioner is running, apply liquid soap to check for any gas leaks around the service valves or caps.
- (14) If there is no leakage, stop the air conditioner.
- (15) Wipe off the soap on the tubing.

This completes air purging with a vacuum pump and the air conditioner is ready for actual operation.

■ Pump Down

In order to protect the earth's environment, be sure to perform pump-down to recover refrigerant gas without releasing it into the atmosphere.

- When relocating or disposing of the A/C, request this service from the dealer where the unit was purchased, or from an appropriate agent. Perform pump-down as described below.

What is pump-down?

- Pump-down refers to recovering the refrigerant gas from the refrigerant cycle at the outdoor unit. This work must be performed during cooling operation. The refrigerant gas cannot be recovered during heating operation.
- During winter, or if the temperature sensor prevents cooling operation, perform "forced cooling operation."

Pump-down procedure

- (1) Fully close the spindles at the valves on the narrow tube side of tubes A, B, C and D. (Refer to Fig. 22.)
- (2) Connect the manifold gauge to the charging port at the valve on the wide tube side of tube D. Purge the air from the charging hose. (Refer to Fig. 23.)

- (3) Perform cooling operation or forced cooling operation.

When the pressure at the low-pressure side is 0.15 – 0.2 MPa (0.5 – 1 kg/cm²G), fully close the spindles at the valves on the wide tube side of tubes A, B, C, and D, and immediately stop operation. (Refer to Fig. 23.)

In the winter, the outdoor unit may stop after 5 - 10 minutes of operation. This is in order to protect the indoor unit heat exchanger from freezing and does not indicate a problem.

- (4) Disconnect the manifold gauge and the inter-unit tubes, and attach the caps and flare nuts. At this point, pump-down is completed. (If the caps and flare nuts are not reattached, there is the danger of gas leakage.) (Refer to Fig. 24.)

If pump-down is not possible

If the A/C cannot be operated because of a malfunction or other cause, use a refrigerant recovery device to recover the refrigerant.

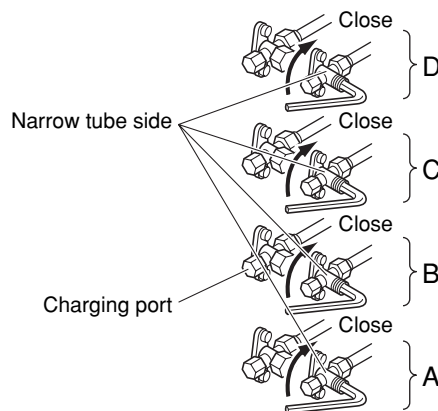

Fig. 22

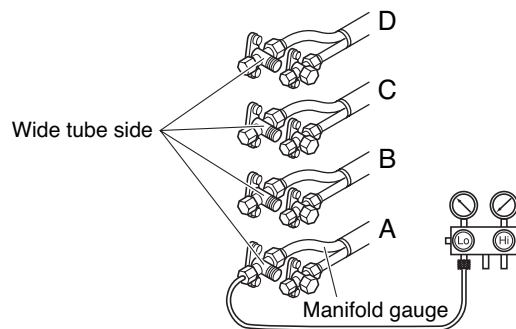

Fig. 23

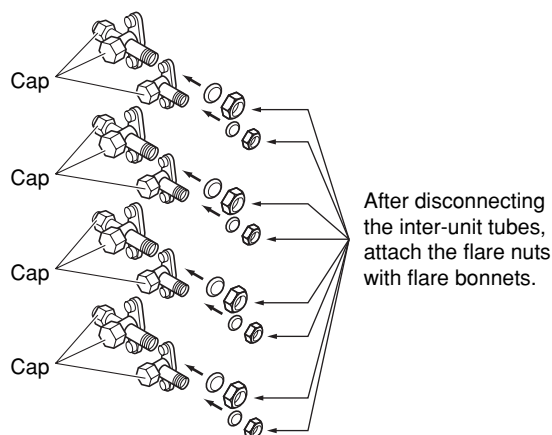

Fig. 24

5. Wiring Instructions

5-1. General Precautions on Wiring

- (1) Before wiring, confirm the rated voltage of the unit as shown on its nameplate, then carry out the wiring closely following the wiring diagram.
- (2) Provide a power outlet to be used exclusively for each unit, with a power supply disconnect and circuit breaker for overcurrent protection provided in the exclusive line.
- (3) To prevent possible hazard due to insulation failure, the unit must be grounded.
- (4) Each wiring connection must be done tightly and in accordance with the wiring system diagram. Wrong wiring may cause the unit to misoperate or become damaged.
- (5) Do not allow wiring to touch the refrigerant tubing, compressor, or any moving parts of the fan.
- (6) Unauthorized changes in the internal wiring can be very dangerous. The manufacturer will accept no responsibility for any damage or misoperation that occurs as a result of such unauthorized changes.

5-2. Recommended Wire Length and Diameter

Regulations on wiring diameter differ from locality to locality. For field wiring requirements, please refer to your local electrical codes. Carefully observe these regulations when carrying out the installation.

Table 6 shows maximum wire lengths for control line and power line and fuse or circuit capacity.

NOTE

Refer to the wiring system diagram (Fig. 25a or 25b) for the meaning of (A), (B), and (C) in Table 6.

Refer to your local codes or in the absence of local codes see the National Electric Code: ANSI/NFPA70.

Table 6

Model	AWG	Max. Power Line Length (ft.) (A)	Max. Control Line Length (ft.) (B) (C)	Fuse or Circuit Capacity
		(#12)	(#14)	
CM1972 / CLM1972		85 (Max.)	82 (Max.)	20 A
CM2472 / CLM2472		85 (Max.)	82 (Max.)	20 A
CM3172 / CLM3172		85 (Max.)	100 (Max.)	20 A

... AWG (American Wire Gauge)



WARNING

- Be sure to comply with local codes on running the wire from the indoor unit to the outdoor unit (size of wire and wiring method, etc.).
- Each wire must be firmly connected.
- No wire should be allowed to touch refrigerant tubing, the compressor, or any moving part.
- Be sure to connect power wires correctly matching up numbers on terminals of the outdoor unit and respective indoor units A – D.



CAUTION

- Be sure to connect the power supply line to the outdoor unit as shown in the wiring diagram. The indoor unit draws its power from the outdoor unit.
- Do not run wiring for antenna, signal, or power lines of television, radio, stereo, telephone, security system, or intercom any closer than 3'4" (1 m) from the power cable and wires between the indoor and outdoor units. Electrical noise may affect the operation.

5-3. Wiring System Diagram

3 indoor units with CM1972/CLM1972

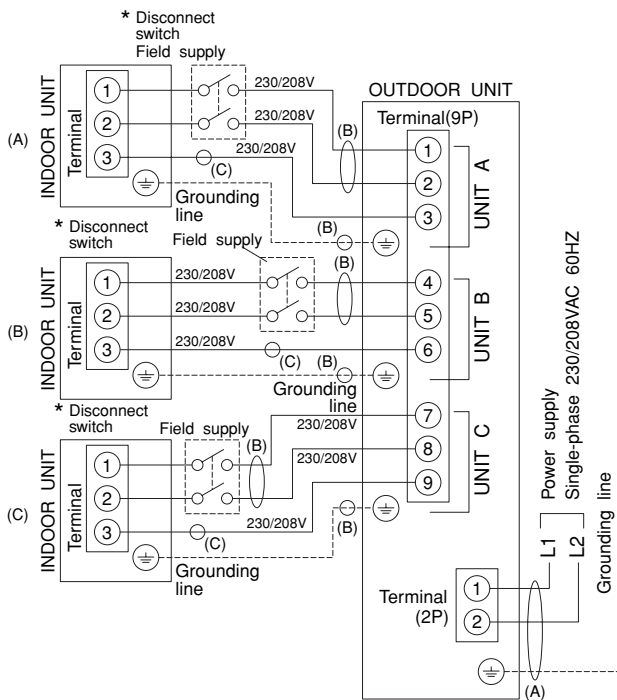

Fig. 25a



WARNING

- To avoid the risk of electric shock, each air conditioner unit must be grounded.
- For the installation of a grounding device, please observe local electrical codes.
- Grounding is necessary, especially for units using inverter circuits, in order to release charged electricity and electrical noise caused by high tension. Otherwise, electrical shock may occur.
- Place a dedicated ground more than 7' (2 m) away from other grounds and do not have it shared with other electric appliances.

*** NOTE**

Disconnect switch may be required by national or local codes.



CAUTION

Always comply with national and local code requirements.

4 indoor units with CM2472/CLM2472, CM3172/CLM3172

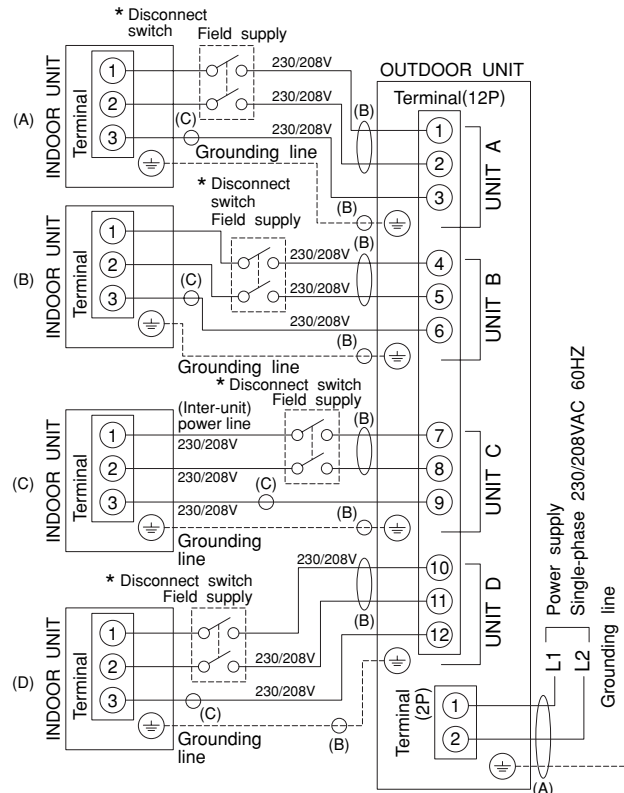

Fig. 25b

5-4. How to Connect Wiring to the Terminal



WARNING

Loose wiring may cause the terminal to overheat or result in unit malfunction. A fire hazard may also exist. Therefore, be sure all wiring is tightly connected.

When connecting each power wire to the corresponding terminal, follow the instructions “How to connect wiring to the terminal” and fasten the wire securely tight with the fixing screw of the terminal plate.

How to connect wiring to the terminal

a) For Indoor Unit

- (1) Cut the wire end with a cutting pliers, then strip the insulation to expose the wire about 9/32" (7 mm). See the label (Fig. 26) near the terminal plate.
- (2) Using a screwdriver, loosen the terminal screw on the terminal plate.
- (3) Insert the wire and tighten the terminal screw completely using a screwdriver.

b) For Outdoor Unit

■ For solid core wiring (or F-cable)

- (1) Cut the wire end with a cutting pliers, then strip the insulation to expose the solid wire about 15/16" (25 mm). (Fig. 27)
- (2) Using a screwdriver, remove the terminal screw(s) on the terminal plate.
- (3) Using the pliers, bend the solid wire to form a loop suitable for the terminal screw.
- (4) Shape the loop wire properly, place it on the terminal plate and fix it securely with the removed terminal screw using a screwdriver.

■ For stranded wiring

- (1) Cut the wire end with a cutting pliers, then strip the insulation to expose the stranded wiring about 3/8" (10 mm) and tightly twist the wire ends. (Figs. 28 and 29)
- (2) Using a screwdriver, remove the terminal screw(s) on the terminal plate.
- (3) Using a ring connector fastener or pliers, securely clamp each stripped wire end with a ring connector. (Fig. 28)
- (4) Place the ring connector wire, and replace and tighten the removed terminal screw using a screwdriver. (Fig. 30)

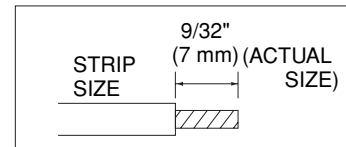

Fig. 26

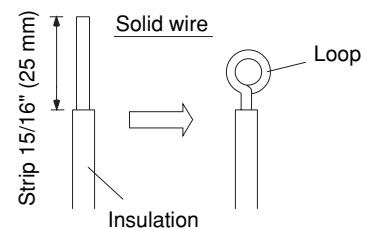

Fig. 27

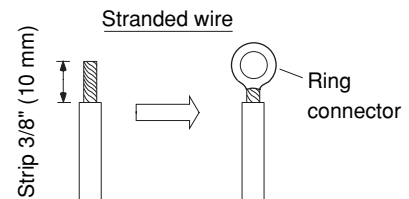

Fig. 28

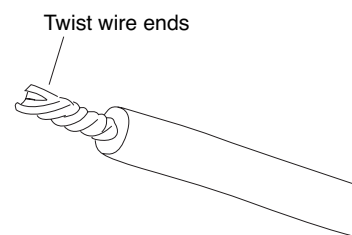

Fig. 29

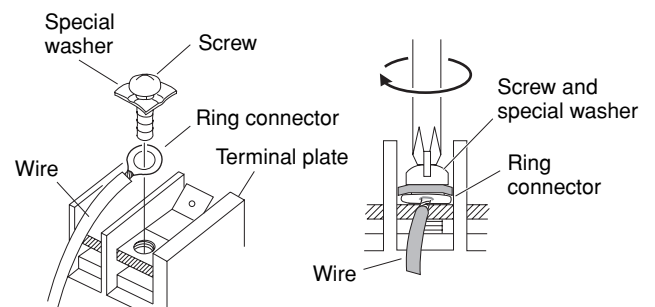

Fig. 30

5-5. Wiring Instructions for the Outdoor Unit



CAUTION

- Be sure to correctly align inter-unit cables A, B, C and D.

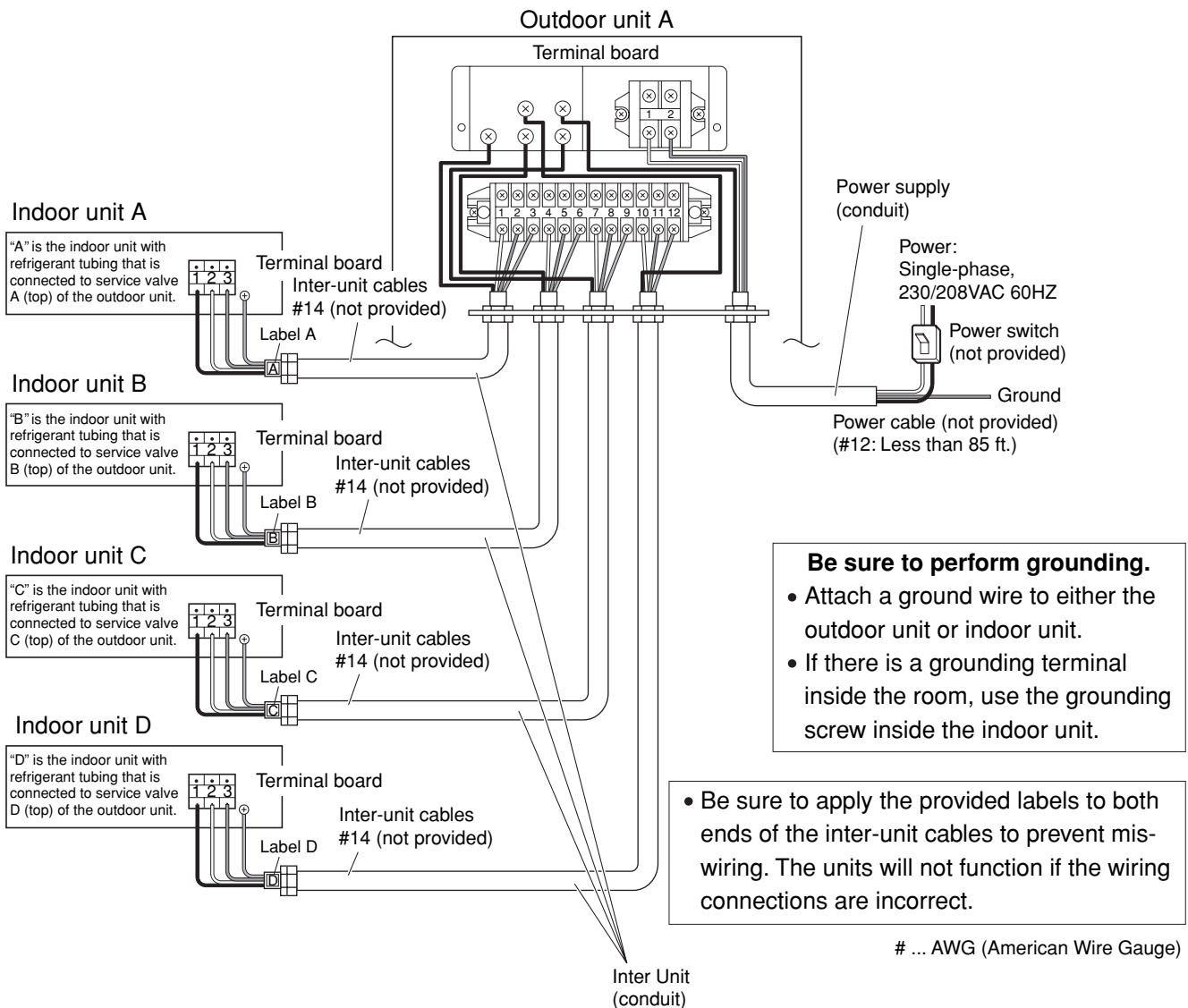

Fig. 31

- Use a dedicated A/C circuit for power.
- To make connections to the outdoor unit, remove the inspection panel and tubing panel.
- Do not bring the inter-unit cables or power cable into contact with tubing or service valves.
- Use outdoor unit cable fasteners and fasten the inter-unit cables at the location where the cables are double-sheathed.
- Arrange the wiring so that the inter-unit cables are contained in the inspection panel and tubing panel, as shown in Fig. 31.

Regulations on wire size differ from locality to locality. For field wiring requirements, please refer to your local electrical codes. Make sure that the installation fully complies with all local and national regulations.

- (1) Remove access panel "C". (Fig. 32)
- (2) Connect the inter-unit and power supply line according to the drawing on the panel side.
- (3) Be sure to size each wire allowing approx. 4" (10 cm) longer than the required length for wiring. Store excess wiring inside the cabinet.
- (4) When connections are completed, check that all connections are correct as shown in the wiring system diagram on panel side.
- (5) Be sure to ground the unit according to your local codes.

6. Test Run

Performing a test run

- Refer to the test run procedures in the indoor unit installation manual.
- Perform the test run separately for each connected indoor unit. If 2 units are operated simultaneously, it is not possible to correctly check for errors in tubing and wiring.

Checking tubing and wiring

Perform the test run and check that operation is normal. If there is an error in tubing or wiring, the refrigerant may flow to indoor unit B when indoor unit A is operated (for example).



- Stop operation immediately if there is an error in tubing or wiring. Turn the power (breaker) to OFF, and check whether the inter-unit cables are connected incorrectly, or whether the narrow tubes A and B are connected in reverse. Correct the connections.
- If there is an error in tubing, pump-down must be performed. Be sure to perform pump-down. After making corrections, again purge the air from the tubes.

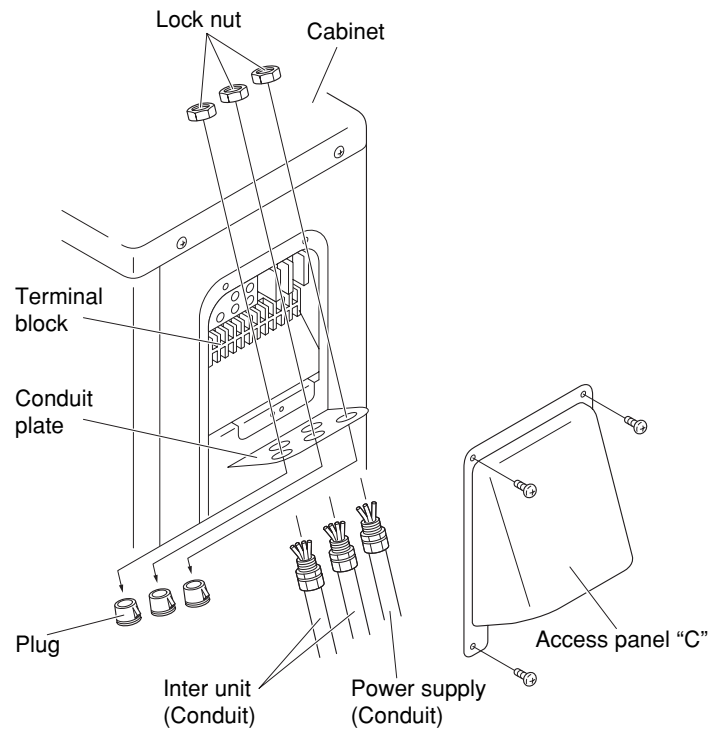

Fig. 32

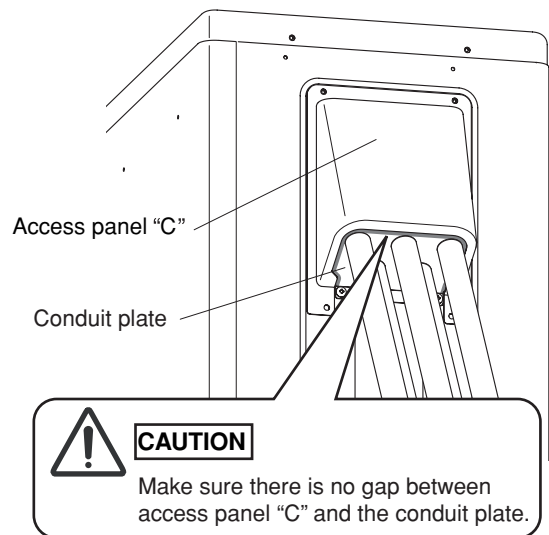

Fig. 33

7. Connecting a Home Automation device

The HA (white) 4P terminal is located on the indoor unit PCB. If a HA device will be used, connect it to this terminal.

8. Installation Check Sheet

- The strength of the installation location is sufficient to support the A/C weight.
- The indoor and outdoor units are installed level and vertically.
- The power and voltage are as specified.
- Inter-unit cables are securely fastened to the terminal board.
- Inter-unit cables are securely fixed.
- The power cord and inter-unit cables are not connected anywhere along their paths.
- The ground wire is securely connected.
- An air purge of the refrigerant circuit has been conducted.
- A leak test of the tubing connections has been performed.
- Thermal insulation has been applied to the tubing connections.
- Drain connections are secure and water drains properly.
- Putty has been used to close the hole in the wall.
- All service valves are fully open.
- Remote controller signals are being positively received.

APPENDIX B UNIT COMBINATION TABLES

< List of Combination Tables >

Name of Combination Table	Model No. of Outdoor Unit	Remarks
3-Room Outdoor Unit Combination Table	CM1972	OI-852-6-4180-818-00-4
4-Room Outdoor Unit Combination Table	CM2472	OI-852-6-4180-819-00-4
4-Room Outdoor Unit Combination Table	CM3172	OI-852-6-4180-820-00-4

NOTE

Be sure to operate the air conditioning system only when 2 or more indoor units have been installed. If operated with only a single unit installed, the returning fluid to the compressor may cause a malfunction.

Save this Combination Table!

Please be sure to hand over this sheet to the user.



3-Room Outdoor Unit Combination Table

CM1972

<Combinations of Connectable Indoor Units>

The combinations of the indoor units listed in Table 1 and Table 2 are combinations solely of those units which can be operated concurrently. In addition to the combinations listed in the table, other combinations of indoor units are possible provided that the following conditions are satisfied.

Conditions:

1. At least two or more indoor units must be connected to the multi outdoor unit. It is not acceptable for only one indoor unit to be connected.
2. The total rated cooling capacity of the indoor units to be connected must be no more than 200% of the rated cooling capacity of the outdoor unit.



CAUTION

In this case, all the indoor units installed must not be operated concurrently under any circumstances. Otherwise, the air conditioner may not run properly and trouble may occur.

Example: When 3 indoor units are connected

at 230V

If the following holds true

- Rated cooling capacity of CM1972 outdoor unit: C=19700 (BTU/h)
- Rated cooling capacity of indoor units: K1, K2, ... (BTU/h)

Then:

$$C \times 2 (200\%) \geq K1 + K2 + \dots$$

$$19700 \times 2 \geq 7500 + 11900 + 17500$$

$$39400 \geq 36900$$

It is therefore possible to connect 3 units with respective capacities of 7500 + 11900 + 17500.

However, since this combination is not found in the 3-room operation column of Table 1, operating all these units concurrently may result in trouble. At a time like this, shut down at least one of the 3 indoor units to match one of the combinations found in the 2-room operation column of Table 1.

at 208V

If the following holds true

- Rated cooling capacity of CM1972 outdoor unit: C=19700 (BTU/h)
- Rated cooling capacity of indoor units: K1, K2, ... (BTU/h)

Then:

$$C \times 2 (200\%) \geq K1 + K2 + \dots$$

$$19700 \times 2 \geq 7500 + 11900 + 17500$$

$$39400 \geq 36900$$

It is therefore possible to connect 3 units with respective capacities of 7500 + 11900 + 17500.

However, since this combination is not found in the 3-room operation column of Table 2, operating all these units concurrently may result in trouble. At a time like this, shut down at least one of the 3 indoor units to match one of the combinations found in the 2-room operation column of Table 2.

NOTE

Be sure to operate the air conditioning system only when 2 or more indoor units have been installed. If operated with only a single unit installed, the returning fluid to the compressor may cause a malfunction.

< Combinations of operatable indoor units >

Voltage Rating : 230V 60Hz

CM1972

(Rated cooling capacity at 230V: 19700 BTU/h)

NOTE

7500 : KMS0772
 9000 : KMS0972
 11900 : KMS1272
 17500 : KMS1872

Table 1

	Indoor Unit Combination		Indoor Unit Capacity (BTU/h)			
			COOLING			
			Room A	Room B	Room C	Total Performance Capacity (Min. - Max.)
Single-room Operation	7500	= 7500	7500			7500 (4700 - 8800)
	9000	= 9000	9000			9000 (4700 - 10900)
	11900	= 11900	11900			11900 (5100 - 12200)
	17500	= 17500	17500			17500 (5400 - 19700)
2-room Operation	7500 + 7500	= 15000	7500	7500		15000 (6800 - 17400)
	7500 + 9000	= 16500	7485	9015		16500 (6800 - 19700)
	7500 + 11900	= 19400	6716	10684		17400 (6800 - 19700)
	7500 + 17500	= 25000	5717	13383		19100 (7100 - 19700)
	9000 + 9000	= 18000	8500	8500		17000 (6800 - 19700)
	9000 + 11900	= 20900	7713	10187		17900 (6800 - 19700)
	9000 + 17500	= 26500	6659	12941		19600 (7100 - 19700)
	11900 + 11900	= 23800	9350	9350		18700 (6800 - 19700)
11900 + 17500	= 29400	7971	11729		19700 (7100 - 19700)	
3-room Operation	7500 + 7500 + 7500	= 22500	6133	6133	6133	18400 (8500 - 19700)
	7500 + 7500 + 9000	= 24000	5835	5835	7029	18700 (9800 - 19700)
	7500 + 7500 + 11900	= 26900	5458	5458	8684	19600 (9800 - 19700)
	7500 + 7500 + 17500	= 32500	4538	4538	10624	19700 (9800 - 19700)
	7500 + 9000 + 9000	= 25500	5779	6961	6961	19700 (9800 - 19700)
	7500 + 9000 + 11900	= 28400	5190	6252	8257	19700 (9800 - 19700)
	7500 + 9000 + 17500	= 34000	4334	5221	10146	19700 (9800 - 19700)
	7500 + 11900 + 11900	= 31300	4711	7495	7495	19700 (9800 - 19700)
	9000 + 9000 + 9000	= 27000	6567	6567	6567	19700 (9800 - 19700)
	9000 + 9000 + 11900	= 29900	5932	5932	7835	19700 (9800 - 19700)
9000 + 11900 + 11900	= 32800	5410	7145	7145	19700 (9800 - 19700)	
11900 + 11900 + 11900	= 35700	6567	6567	6567	19700 (9800 - 19700)	

- The table lists the wall-mounted type of indoor units as representative models.

Voltage Rating : 208V 60Hz

CM1972

(Rated cooling capacity at 208V: 19700 BTU/h)

NOTE

7500 : KMS0772
9000 : KMS0972
11900 : KMS1272
17500 : KMS1872

Table 2

	Indoor Unit Combination		Indoor Unit Capacity (BTU/h)			
			COOLING			
			Room A	Room B	Room C	Total Performance Capacity (Min. - Max.)
Single-room Operation	7500	= 7500	7500			7500 (4700 - 8800)
	9000	= 9000	9000			9000 (4700 - 10900)
	11900	= 11900	11900			11900 (5100 - 12200)
	17500	= 17500	17500			17500 (5400 - 19700)
2-room Operation	7500 + 7500	= 15000	7500	7500		15000 (6800 - 17400)
	7500 + 9000	= 16500	7485	9015		16500 (6800 - 19700)
	7500 + 11900	= 19400	6716	10684		17400 (6800 - 19700)
	7500 + 17500	= 25000	5717	13383		19100 (7100 - 19700)
	9000 + 9000	= 18000	8500	8500		17000 (6800 - 19700)
	9000 + 11900	= 20900	7713	10187		17900 (6800 - 19700)
	9000 + 17500	= 26500	6659	12941		19600 (7100 - 19700)
	11900 + 11900	= 23800	9350	9350		18700 (6800 - 19700)
11900 + 17500	= 29400	7971	11729		19700 (7100 - 19700)	
3-room Operation	7500 + 7500 + 7500	= 22500	6133	6133	6133	18400 (8500 - 19700)
	7500 + 7500 + 9000	= 24000	5835	5835	7029	18700 (9800 - 19700)
	7500 + 7500 + 11900	= 26900	5458	5458	8684	19600 (9800 - 19700)
	7500 + 7500 + 17500	= 32500	4538	4538	10624	19700 (9800 - 19700)
	7500 + 9000 + 9000	= 25500	5779	6961	6961	19700 (9800 - 19700)
	7500 + 9000 + 11900	= 28400	5190	6252	8257	19700 (9800 - 19700)
	7500 + 9000 + 17500	= 34000	4334	5221	10146	19700 (9800 - 19700)
	7500 + 11900 + 11900	= 31300	4711	7495	7495	19700 (9800 - 19700)
	9000 + 9000 + 9000	= 27000	6567	6567	6567	19700 (9800 - 19700)
	9000 + 9000 + 11900	= 29900	5932	5932	7835	19700 (9800 - 19700)
9000 + 11900 + 11900	= 32800	5410	7145	7145	19700 (9800 - 19700)	
11900 + 11900 + 11900	= 35700	6567	6567	6567	19700 (9800 - 19700)	

- The table lists the wall-mounted type of indoor units as representative models.

Save this Combination Table!

Please be sure to hand over this sheet to the user.



4-Room Outdoor Unit Combination Table

CM2472

<Combinations of Connectable Indoor Units>

The combinations of the indoor units listed in Table 1 and Table 2 are combinations solely of those units which can be operated concurrently. In addition to the combinations listed in the table, other combinations of indoor units are possible provided that the following conditions are satisfied.

Conditions:

1. At least two or more indoor units must be connected to the multi outdoor unit. It is not acceptable for only one indoor unit to be connected.
2. The total rated cooling capacity of the indoor units to be connected must be no more than 200% of the rated cooling capacity of the outdoor unit.



CAUTION

In this case, all the indoor units installed must not be operated concurrently under any circumstances. Otherwise, the air conditioner may not run properly and trouble may occur.

Example: When 4 indoor units are connected

at 230V

If the following holds true

- Rated cooling capacity of CM2472 outdoor unit: C=25400 (BTU/h)
- Rated cooling capacity of indoor units: K1, K2, ... (BTU/h)

Then:

$$C \times 2 (200\%) \geq K1 + K2 + \dots$$

$$25400 \times 2 \geq 7500 + 7500 + 7500 + 17500$$

$$50800 \geq 40000$$

It is therefore possible to connect 4 units with respective capacities of 7500 + 7500 + 7500 + 17500.

However, since this combination is not found in the 4-room operation column of Table 1, operating all these units concurrently may result in trouble. At a time like this, shut down at least one of the 4 indoor units to match one of the combinations found in the 3-room operation column of Table 1.

at 208V

If the following holds true

- Rated cooling capacity of CM2472 outdoor unit: C=24400 (BTU/h)
- Rated cooling capacity of indoor units: K1, K2, ... (BTU/h)

Then:

$$C \times 2 (200\%) \geq K1 + K2 + \dots$$

$$24400 \times 2 \geq 7500 + 7500 + 7500 + 17500$$

$$48800 \geq 40000$$

It is therefore possible to connect 4 units with respective capacities of 7500 + 7500 + 7500 + 17500.

However, since this combination is not found in the 4-room operation column of Table 2, operating all these units concurrently may result in trouble. At a time like this, shut down at least one of the 4 indoor units to match one of the combinations found in the 3-room operation column of Table 2.

NOTE

Be sure to operate the air conditioning system only when 2 or more indoor units have been installed.

If operated with only a single unit installed, the returning fluid to the compressor may cause a malfunction.

< Combinations of operatable indoor units >

Voltage Rating : 230V 60Hz

CM2472

(Rated cooling capacity at 230V: 25400 BTU/h)

NOTE

7500 : KMS0772
 9000 : KMS0972
 11900 : KMS1272
 17500 : KMS1872
 24200 : KMS2472

Table 1

	Indoor Unit Combination		Indoor Unit Capacity (BTU/h)					Total Performance Capacity (Min. - Max.)	
			COOLING						
			Room A	Room B	Room C	Room D			
Single-room Operation	7500	= 7500	7500					7500 (4700 - 8800)	
	9000	= 9000	9000					9000 (4700 - 10900)	
	11900	= 11900	11900					11900 (5100 - 12200)	
	17500	= 17500	17500					17500 (5400 - 19700)	
	24200	= 24200	23200					23200 (5400 - 23200)	
2-room Operation	7500 + 7500	= 15000	7500	7500				15000 (6800 - 17400)	
	7500 + 9000	= 16500	7485	9015				16500 (6800 - 19700)	
	7500 + 11900	= 19400	7488	11912				19400 (6800 - 22800)	
	7500 + 17500	= 25000	7124	16676				23800 (7100 - 25200)	
	7500 + 24200	= 31700	6009	19391				25400 (7100 - 25400)	
	9000 + 9000	= 18000	9000	9000				18000 (6800 - 21400)	
	9000 + 11900	= 20900	8876	11724				20600 (6800 - 23200)	
	9000 + 17500	= 26500	8494	16506				25000 (7100 - 25400)	
	9000 + 24200	= 33200	6904	18496				25400 (7100 - 25400)	
	11900 + 11900	= 23800	11400	11400				22800 (6800 - 24800)	
	11900 + 17500	= 29400	10277	15123				25400 (7100 - 25400)	
	11900 + 24200	= 36100	8387	17013				25400 (7100 - 25400)	
17500 + 17500	= 35000	12700	12700				25400 (7100 - 25400)		
3-room Operation	7500 + 7500 + 7500	= 22500	7333	7333	7333			22000 (8500 - 25400)	
	7500 + 7500 + 9000	= 24000	7177	7177	8645			23000 (9800 - 25400)	
	7500 + 7500 + 11900	= 26900	7073	7073	11253			25400 (9800 - 25400)	
	7500 + 7500 + 17500	= 32500	5851	5851	13697			25400 (9800 - 25400)	
	7500 + 9000 + 9000	= 25500	7099	8551	8551			24200 (9800 - 25400)	
	7500 + 9000 + 11900	= 28400	6692	8061	10647			25400 (9800 - 25400)	
	7500 + 9000 + 17500	= 34000	5588	6731	13081			25400 (9800 - 25400)	
	7500 + 11900 + 11900	= 31300	6074	9663	9663			25400 (9800 - 25400)	
	7500 + 11900 + 17500	= 36900	5150	8194	12056			25400 (9800 - 25400)	
	9000 + 9000 + 9000	= 27000	8467	8467	8467			25400 (9800 - 25400)	
	9000 + 9000 + 11900	= 29900	7649	7649	10102			25400 (9800 - 25400)	
	9000 + 9000 + 17500	= 35500	6441	6441	12518			25400 (9800 - 25400)	
	9000 + 11900 + 11900	= 32800	6975	9212	9212			25400 (9800 - 25400)	
	9000 + 11900 + 17500	= 38400	5957	7867	11576			25400 (9800 - 25400)	
11900 + 11900 + 11900	= 35700	8467	8467	8467			25400 (9800 - 25400)		
11900 + 11900 + 17500	= 41300	7317	7317	10766			25400 (9800 - 25400)		
4-room Operation									

IMPORTANT! (Concurrent operation of 4 indoor units prohibited)
 This multi outdoor unit allows up to four indoor units to be connected.
 However, all four indoor units must not be operated concurrently.
 Otherwise, the air conditioner may not run properly.
 Up to three indoor units may be operated concurrently.

• The table lists the wall-mounted type of indoor units as representative models.

Voltage Rating : 208V 60Hz

CM2472

(Rated cooling capacity at 208V: 24400 BTU/h)

NOTE

7500 : KMS0772
 9000 : KMS0972
 11900 : KMS1272
 17500 : KMS1872
 24200 : KMS2472

Table 2

	Indoor Unit Combination		Indoor Unit Capacity (BTU/h)				COOLING	
			Room A	Room B	Room C	Room D	Total Performance	
							Capacity	(Min. - Max.)
Single-room Operation	7500	= 7500	7500				7500 (4700 - 8800)	
	9000	= 9000	9000				9000 (4700 - 10900)	
	11900	= 11900	11900				11900 (5100 - 12200)	
	17500	= 17500	17500				17500 (5400 - 19700)	
	24200	= 24200	22400				22400 (5400 - 22400)	
2-room Operation	7500 + 7500	= 15000	7500	7500			15000 (6800 - 17400)	
	7500 + 9000	= 16500	7485	9015			16500 (6800 - 19700)	
	7500 + 11900	= 19400	7488	11912			19400 (6800 - 22800)	
	7500 + 17500	= 25000	7124	16676			23800 (7100 - 24200)	
	7500 + 24200	= 31700	5772	18628			24400 (7100 - 24400)	
	9000 + 9000	= 18000	9000	9000			18000 (6800 - 21400)	
	9000 + 11900	= 20900	8876	11724			20600 (6800 - 23200)	
	9000 + 17500	= 26500	8290	16110			24400 (7100 - 24400)	
	9000 + 24200	= 33200	6632	17768			24400 (7100 - 24400)	
	11900 + 11900	= 23800	11400	11400			22800 (6800 - 23200)	
	11900 + 17500	= 29400	9873	14527			24400 (7100 - 24400)	
	11900 + 24200	= 36100	8057	16343			24400 (7100 - 24400)	
17500 + 17500	= 35000	12200	12200			24400 (7100 - 24400)		
3-room Operation	7500 + 7500 + 7500	= 22500	7333	7333	7333		22000 (8500 - 24200)	
	7500 + 7500 + 9000	= 24000	7177	7177	8645		23000 (9800 - 24200)	
	7500 + 7500 + 11900	= 26900	6739	6739	10722		24200 (9800 - 24400)	
	7500 + 7500 + 17500	= 32500	5575	5575	13050		24200 (9800 - 24400)	
	7500 + 9000 + 9000	= 25500	7099	8551	8551		24200 (9800 - 24200)	
	7500 + 9000 + 11900	= 28400	6429	7744	10228		24400 (9800 - 24400)	
	7500 + 9000 + 17500	= 34000	5368	6466	12566		24400 (9800 - 24400)	
	7500 + 11900 + 11900	= 31300	5835	9283	9283		24400 (9800 - 24400)	
	7500 + 11900 + 17500	= 36900	4947	7871	11582		24400 (9800 - 24400)	
	9000 + 9000 + 9000	= 27000	8133	8133	8133		24400 (9800 - 24400)	
	9000 + 9000 + 11900	= 29900	7348	7348	9705		24400 (9800 - 24400)	
	9000 + 9000 + 17500	= 35500	6188	6188	12025		24400 (9800 - 24400)	
	9000 + 11900 + 11900	= 32800	6701	8850	8850		24400 (9800 - 24400)	
	9000 + 11900 + 17500	= 38400	5722	7558	11120		24400 (9800 - 24400)	
11900 + 11900 + 11900	= 35700	8133	8133	8133		24400 (9800 - 24400)		
11900 + 11900 + 17500	= 41300	7029	7029	10342		24400 (9800 - 24400)		
4-room Operation								

IMPORTANT! (Concurrent operation of 4 indoor units prohibited)

This multi outdoor unit allows up to four indoor units to be connected. However, all four indoor units must not be operated concurrently. Otherwise, the air conditioner may not run properly. Up to three indoor units may be operated concurrently.

- The table lists the wall-mounted type of indoor units as representative models.

Save this Combination Table!

Please be sure to hand over this sheet to the user.



4-Room Outdoor Unit Combination Table

CM3172

<Combinations of Connectable Indoor Units>

The combinations of the indoor units listed in Table 1 and Table 2 are combinations solely of those units which can be operated concurrently. In addition to the combinations listed in the table, other combinations of indoor units are possible provided that the following conditions are satisfied.

Conditions:

1. At least two or more indoor units must be connected to the multi outdoor unit. It is not acceptable for only one indoor unit to be connected.
2. The total rated cooling capacity of the indoor units to be connected must be no more than 200% of the rated cooling capacity of the outdoor unit.



CAUTION

In this case, all the indoor units installed must not be operated concurrently under any circumstances. Otherwise, the air conditioner may not run properly and trouble may occur.

Example: When 4 indoor units are connected

at 230V

If the following holds true

- Rated cooling capacity of CM3172 outdoor unit: C=30600 (BTU/h)
- Rated cooling capacity of indoor units: K1, K2, ... (BTU/h)

Then:

$$C \times 2 (200\%) \geq K1 + K2 + \dots$$

$$30600 \times 2 \geq 7500 + 7500 + 11900 + 24200$$

$$61200 \geq 51100$$

It is therefore possible to connect 4 units with respective capacities of 7500 + 7500 + 11900 + 24200.

However, since this combination is not found in the 4-room operation column of Table 1, operating all these units concurrently may result in trouble. At a time like this, shut down at least one of the 4 indoor units to match one of the combinations found in the 3-room operation column of Table 1.

at 208V

If the following holds true

- Rated cooling capacity of CM3172 outdoor unit: C=28600 (BTU/h)
- Rated cooling capacity of indoor units: K1, K2, ... (BTU/h)

Then:

$$C \times 2 (200\%) \geq K1 + K2 + \dots$$

$$28600 \times 2 \geq 7500 + 7500 + 11900 + 24200$$

$$57200 \geq 51100$$

It is therefore possible to connect 4 units with respective capacities of 7500 + 7500 + 11900 + 24200.

However, since this combination is not found in the 4-room operation column of Table 2, operating all these units concurrently may result in trouble. At a time like this, shut down at least one of the 4 indoor units to match one of the combinations found in the 3-room operation column of Table 2.

NOTE

Be sure to operate the air conditioning system only when 2 or more indoor units have been installed.

If operated with only a single unit installed, the returning fluid to the compressor may cause a malfunction.

< Combinations of operatable indoor units >

Voltage Rating : 230V 60Hz

CM3172

(Rated cooling capacity at 230V: 30600 BTU/h)

NOTE

7500 : KMS0772
 9000 : KMS0972
 11900 : KMS1272
 17500 : KMS1872
 24200 : KMS2472

Table 1

	Indoor Unit Combination		Indoor Unit Capacity (BTU/h)							
			COOLING							
			Room A	Room B	Room C	Room D	Total Performance			
						Capacity	(Min. - Max.)			
Single-room Operation	7500	= 7500	7500					7500	(4000 - 8800)	
	9000	= 9000	9000					9000	(4400 - 10900)	
	11900	= 11900	11900					11900	(4700 - 12200)	
	17500	= 17500	17500					17500	(5100 - 19700)	
	24200	= 24200	24200					24200	(5400 - 25200)	
2-room Operation	7500 + 7500	= 15000	7500	7500				15000	(4400 - 17400)	
	7500 + 9000	= 16500	7500	9000				16500	(5100 - 19700)	
	7500 + 11900	= 19400	7500	11900				19400	(5800 - 22800)	
	7500 + 17500	= 25000	7320	17080				24400	(7500 - 26200)	
	7500 + 24200	= 31700	6625	21375				28000	(7800 - 30000)	
	9000 + 9000	= 18000	9000	9000				18000	(5800 - 22000)	
	9000 + 11900	= 20900	8957	11843				20800	(6400 - 25200)	
	9000 + 17500	= 26500	8626	16774				25400	(7800 - 29000)	
	9000 + 24200	= 33200	7861	21139				29000	(7800 - 30000)	
	11900 + 11900	= 23800	11900	11900				23800	(7500 - 28600)	
	11900 + 17500	= 29400	10848	15952				26800	(8800 - 30000)	
	11900 + 24200	= 36100	9625	19575				29200	(8800 - 30000)	
	17500 + 17500	= 35000	14500	14500				29000	(8800 - 30000)	
	17500 + 24200	= 41700	12296	17004				29300	(9200 - 30000)	
3-room Operation	7500 + 7500 + 7500	= 22500	7467	7467	7467			22400	(6800 - 26200)	
	7500 + 7500 + 9000	= 24000	7500	7500	9000			24000	(7500 - 26600)	
	7500 + 7500 + 11900	= 26900	7082	7082	11236			25400	(8100 - 26800)	
	7500 + 7500 + 17500	= 32500	6600	6600	15400			28600	(9200 - 30600)	
	7500 + 7500 + 24200	= 39200	5587	5587	18027			29200	(9800 - 30600)	
	7500 + 9000 + 9000	= 25500	7294	8753	8753			24800	(7800 - 27200)	
	7500 + 9000 + 11900	= 28400	6972	8366	11062			26400	(8800 - 27600)	
	7500 + 9000 + 17500	= 34000	6309	7571	14721			28600	(9800 - 30600)	
	7500 + 9000 + 24200	= 40700	5381	6457	17362			29200	(9800 - 30600)	
	7500 + 11900 + 11900	= 31300	6613	10493	10493			27600	(9200 - 28600)	
	7500 + 11900 + 17500	= 36900	5935	9417	13848			29200	(9800 - 30600)	
	7500 + 11900 + 24200	= 43600	5023	7970	16207			29200	(9800 - 30600)	
	7500 + 17500 + 17500	= 42500	5153	12024	12024			29200	(9800 - 30600)	
	7500 + 17500 + 24200	= 49200	4451	10386	14363			29200	(9800 - 30600)	
	9000 + 9000 + 9000	= 27000	8533	8533	8533			25600	(8500 - 27200)	
	9000 + 9000 + 11900	= 29900	8187	8187	10825			27200	(9200 - 28200)	
	9000 + 9000 + 17500	= 35500	7352	7352	14296			29000	(9800 - 30600)	
	9000 + 9000 + 24200	= 42200	6185	6185	16630			29000	(9800 - 30600)	
	9000 + 11900 + 11900	= 32800	7848	10376	10376			28600	(9200 - 29200)	
	9000 + 11900 + 17500	= 38400	6844	9049	13307			29200	(9800 - 30600)	
	9000 + 11900 + 24200	= 45100	5827	7705	15668			29200	(9800 - 30600)	
	9000 + 17500 + 17500	= 44000	5973	11614	11614			29200	(9800 - 30600)	
	11900 + 11900 + 11900	= 35700	9267	9267	9267			27800	(9800 - 29000)	
	11900 + 11900 + 17500	= 41300	8414	8414	12373			29200	(9800 - 30600)	
11900 + 11900 + 24200	= 48000	7239	7239	14722			29200	(9800 - 30600)		
11900 + 17500 + 17500	= 46900	7409	10896	10896			29200	(9800 - 30600)		
4-room Operation	7500 + 7500 + 7500 + 7500	= 30000	6800	6800	6800	6800		27200	(9800 - 28200)	
	7500 + 7500 + 7500 + 9000	= 31500	6667	6667	6667	8000		28000	(9800 - 28200)	
	7500 + 7500 + 7500 + 11900	= 34400	6235	6235	6235	9894		28600	(9800 - 28600)	
	7500 + 7500 + 7500 + 17500	= 40000	5738	5738	5738	13388		30600	(9800 - 30600)	
	7500 + 7500 + 7500 + 24200	= 46700	4914	4914	4914	15857		30600	(9800 - 30600)	
	7500 + 7500 + 9000 + 9000	= 33000	6409	6409	7691	7691		28200	(9800 - 28200)	
	7500 + 7500 + 9000 + 11900	= 35900	6058	6058	7270	9613		29000	(9800 - 29000)	
	7500 + 7500 + 9000 + 17500	= 41500	5530	5530	6636	12904		30600	(9800 - 30600)	
	7500 + 7500 + 9000 + 24200	= 48200	4761	4761	5714	15363		30600	(9800 - 30600)	
	7500 + 7500 + 11900 + 11900	= 38800	5915	5915	9385	9385		30600	(9800 - 30600)	
	7500 + 7500 + 11900 + 17500	= 44400	5169	5169	8201	12061		30600	(9800 - 30600)	
	7500 + 7500 + 17500 + 17500	= 50000	4590	4590	10710	10710		30600	(9800 - 30600)	
	7500 + 9000 + 9000 + 9000	= 34500	6217	7461	7461	7461		28600	(9800 - 28600)	
	7500 + 9000 + 9000 + 11900	= 37400	6136	7364	7364	9736		30600	(9800 - 30600)	
	7500 + 9000 + 9000 + 17500	= 43000	5337	6405	6405	12453		30600	(9800 - 30600)	
	7500 + 9000 + 11900 + 11900	= 40300	5695	6834	9036	9036		30600	(9800 - 30600)	
	7500 + 9000 + 11900 + 17500	= 45900	5000	6000	7933	11667		30600	(9800 - 30600)	
	7500 + 11900 + 11900 + 11900	= 43200	5313	8429	8429	8429		30600	(9800 - 30600)	
	7500 + 11900 + 11900 + 17500	= 48800	4703	7462	7462	10973		30600	(9800 - 30600)	
	9000 + 9000 + 9000 + 9000	= 36000	7650	7650	7650	7650		30600	(9800 - 30600)	
	9000 + 9000 + 9000 + 11900	= 38900	7080	7080	7080	9361		30600	(9800 - 30600)	
	9000 + 9000 + 9000 + 17500	= 44500	6189	6189	6189	12034		30600	(9800 - 30600)	
	9000 + 9000 + 11900 + 11900	= 41800	6589	6589	8711	8711		30600	(9800 - 30600)	
	9000 + 9000 + 11900 + 17500	= 47400	5810	5810	7682	11297		30600	(9800 - 30600)	
	9000 + 11900 + 11900 + 11900	= 44700	6161	8146	8146	8146		30600	(9800 - 30600)	
	11900 + 11900 + 11900 + 11900	= 47600	7650	7650	7650	7650		30600	(9800 - 30600)	

• The table lists the wall-mounted type of indoor units as representative models.

Voltage Rating : 208V 60Hz

CM3172

(Rated cooling capacity at 208V: 28600 BTU/h)

NOTE

7500 : KMS0772
 9000 : KMS0972
 11900 : KMS1272
 17500 : KMS1872
 24200 : KMS2472

Table 2

	Indoor Unit Combination		Indoor Unit Capacity (BTU/h)				
			COOLING				Total Performance
			Room A	Room B	Room C	Room D	
Single-room Operation	7500	= 7500	7500				7500 (4000 - 8800)
	9000	= 9000	9000				9000 (4400 - 10900)
	11900	= 11900	11900				11900 (4700 - 12200)
	17500	= 17500	17500				17500 (5100 - 19700)
	24200	= 24200	24200				24200 (5400 - 24800)
2-room Operation	7500 + 7500	= 15000	7500	7500			15000 (4400 - 17400)
	7500 + 9000	= 16500	7500	9000			16500 (5100 - 19700)
	7500 + 11900	= 19400	7500	11900			19400 (5800 - 22800)
	7500 + 17500	= 25000	7320	17080			24400 (7500 - 26200)
	7500 + 24200	= 31700	6625	21375			28000 (7800 - 27600)
	9000 + 9000	= 18000	9000	9000			18000 (5800 - 22000)
	9000 + 11900	= 20900	8957	11843			20800 (6400 - 25200)
	9000 + 17500	= 26500	8626	16774			25400 (7800 - 27600)
	9000 + 24200	= 33200	7373	19827			27200 (7800 - 27600)
	11900 + 11900	= 23800	11900	11900			23800 (7500 - 27600)
	11900 + 17500	= 29400	10848	15952			26800 (8800 - 27600)
	11900 + 24200	= 36100	9098	18502			27600 (8800 - 27600)
	17500 + 17500	= 35000	13600	13600			27200 (8800 - 27600)
	17500 + 24200	= 41700	11583	16017			27600 (9200 - 27600)
3-room Operation	7500 + 7500 + 7500	= 22500	7467	7467	7467		22400 (6800 - 24800)
	7500 + 7500 + 9000	= 24000	7500	7500	9000		24000 (7500 - 25200)
	7500 + 7500 + 11900	= 26900	6747	6747	10706		24200 (8100 - 25400)
	7500 + 7500 + 17500	= 32500	6185	6185	14431		26800 (9200 - 27600)
	7500 + 7500 + 24200	= 39200	5281	5281	17039		27600 (9800 - 27600)
	7500 + 9000 + 9000	= 25500	7118	8541	8541		24200 (7800 - 25400)
	7500 + 9000 + 11900	= 28400	6444	7732	10224		24400 (8800 - 25800)
	7500 + 9000 + 17500	= 34000	5912	7094	13794		26800 (9800 - 27600)
	7500 + 9000 + 24200	= 40700	5086	6103	16411		27600 (9800 - 27600)
	7500 + 11900 + 11900	= 31300	5799	9201	9201		24200 (9200 - 27600)
	7500 + 11900 + 17500	= 36900	5610	8901	13089		27600 (9800 - 27600)
	7500 + 11900 + 24200	= 43600	4748	7533	15319		27600 (9800 - 27600)
	7500 + 17500 + 17500	= 42500	4871	11365	11365		27600 (9800 - 27600)
	7500 + 17500 + 24200	= 49200	4207	9817	13576		27600 (9800 - 27600)
	9000 + 9000 + 9000	= 27000	8267	8267	8267		24800 (8500 - 26200)
	9000 + 9000 + 11900	= 29900	7284	7284	9631		24200 (9200 - 25400)
	9000 + 9000 + 17500	= 35500	6439	6439	12521		25400 (9800 - 27600)
	9000 + 9000 + 24200	= 42200	5886	5886	15827		27600 (9800 - 27600)
	9000 + 11900 + 11900	= 32800	6805	8998	8998		24800 (9200 - 26200)
	9000 + 11900 + 17500	= 38400	6469	8553	12578		27600 (9800 - 27600)
	9000 + 11900 + 24200	= 45100	5508	7282	14810		27600 (9800 - 27600)
	9000 + 17500 + 17500	= 44000	5645	10977	10977		27600 (9800 - 27600)
11900 + 11900 + 11900	= 35700	8467	8467	8467		25400 (9800 - 27600)	
11900 + 11900 + 17500	= 41300	7953	7953	11695		27600 (9800 - 27600)	
11900 + 11900 + 24200	= 48000	6843	6843	13915		27600 (9800 - 27600)	
11900 + 17500 + 17500	= 46900	7003	10299	10299		27600 (9800 - 27600)	
4-room Operation	7500 + 7500 + 7500 + 7500	= 30000	6300	6300	6300	6300	25200 (9800 - 25200)
	7500 + 7500 + 7500 + 9000	= 31500	6048	6048	6048	7257	25400 (9800 - 25400)
	7500 + 7500 + 7500 + 11900	= 34400	5625	5625	5625	8925	25800 (9800 - 25800)
	7500 + 7500 + 7500 + 17500	= 40000	5363	5363	5363	12513	28600 (9800 - 28600)
	7500 + 7500 + 7500 + 24200	= 46700	4593	4593	4593	14821	28600 (9800 - 28600)
	7500 + 7500 + 9000 + 9000	= 33000	5864	5864	7036	7036	25800 (9800 - 25800)
	7500 + 7500 + 9000 + 11900	= 35900	5557	5557	6669	8817	26600 (9800 - 26600)
	7500 + 7500 + 9000 + 17500	= 41500	5169	5169	6202	12060	28600 (9800 - 28600)
	7500 + 7500 + 9000 + 24200	= 48200	4450	4450	5340	14359	28600 (9800 - 28600)
	7500 + 7500 + 11900 + 11900	= 38800	5528	5528	8772	8772	28600 (9800 - 28600)
	7500 + 7500 + 11900 + 17500	= 44400	4831	4831	7665	11273	28600 (9800 - 28600)
	7500 + 7500 + 17500 + 17500	= 50000	4290	4290	10010	10010	28600 (9800 - 28600)
	7500 + 9000 + 9000 + 9000	= 34500	5696	6835	6835	6835	26200 (9800 - 26200)
	7500 + 9000 + 9000 + 11900	= 37400	5735	6882	6882	9100	28600 (9800 - 28600)
	7500 + 9000 + 9000 + 17500	= 43000	4988	5986	5986	11640	28600 (9800 - 28600)
	7500 + 9000 + 11900 + 11900	= 40300	5323	6387	8445	8445	28600 (9800 - 28600)
	7500 + 9000 + 11900 + 17500	= 45900	4673	5608	7415	10904	28600 (9800 - 28600)
	7500 + 11900 + 11900 + 11900	= 43200	4965	7878	7878	7878	28600 (9800 - 28600)
	7500 + 11900 + 11900 + 17500	= 48800	4395	6974	6974	10256	28600 (9800 - 28600)
	9000 + 9000 + 9000 + 9000	= 36000	7150	7150	7150	7150	28600 (9800 - 28600)
	9000 + 9000 + 9000 + 11900	= 38900	6617	6617	6617	8749	28600 (9800 - 28600)
	9000 + 9000 + 9000 + 17500	= 44500	5784	5784	5784	11247	28600 (9800 - 28600)
	9000 + 9000 + 11900 + 11900	= 41800	6158	6158	8142	8142	28600 (9800 - 28600)
	9000 + 9000 + 11900 + 17500	= 47400	5430	5430	7180	10559	28600 (9800 - 28600)
	9000 + 11900 + 11900 + 11900	= 44700	5758	7614	7614	7614	28600 (9800 - 28600)
	11900 + 11900 + 11900 + 11900	= 47600	7150	7150	7150	7150	28600 (9800 - 28600)

● The table lists the wall-mounted type of indoor units as representative models.

SANYO Commercial Solutions
A Division of SANYO North America Corporation
1300 Michael Drive, Suite A
Wood Dale, IL 60191, U.S.A.

Sanyo Canada Inc.
1-300 Applewood Crescent, Concord, Ontario L4K 5C7, CANADA
Oct. / 2008 (T)