

Little GIANT®

10E SERIES



Features

- Handles liquids and solid waste materials up to 3/4" diameter
- Cast iron pump housing with protective epoxy coating for corrosion resistance
- Oil-filled motor housing for lifetime lubrication and rapid heat dissipation
- Stainless steel fasteners
- Mechanical seals (stainless steel spring, nitrile parts, Carbon and ceramic faces)
- Bearings: Upper and lower ball bearings
- Thermal overload protection
- Manual and Automatic models
- Automatic operation has 9" to 14" "On" level and 2" to 6" "Off" level range with piggyback remote float switch
- All 115 volt models are UL/CSA listed

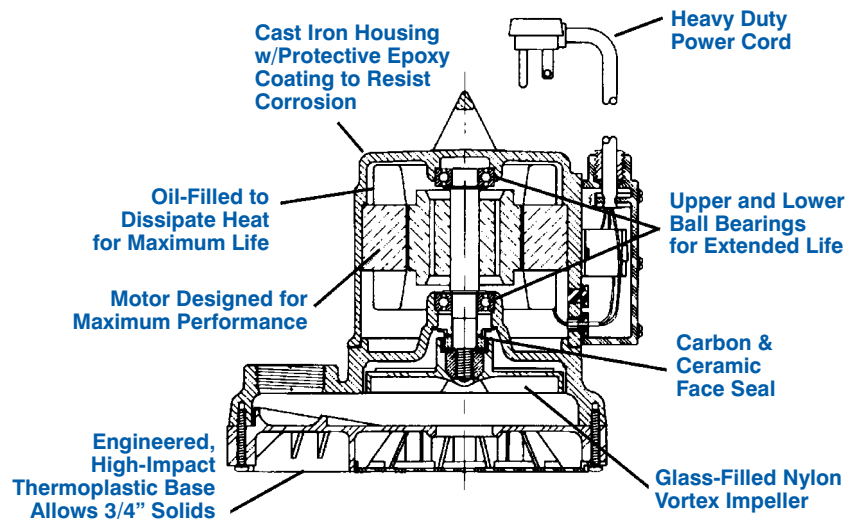

The Model 10E Series De-watering and Effluent pumps are for commercial and light industrial applications. Pumps feature a 1-1/2" discharge, with a lift of 26', ABS base, vortex nylon impeller and glass-filled electrical case.

10E SERIES

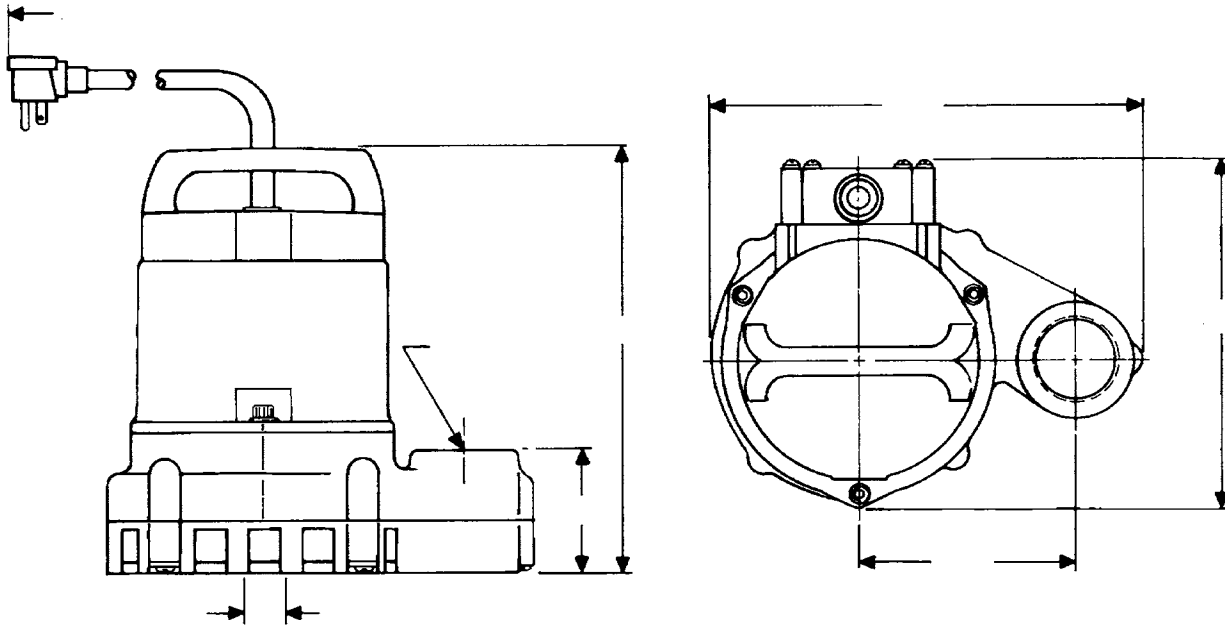

Specifications

Model No.	Item No.	Listing	HP	Volts	Solids Size (dia. in.)	Running Amps/Watts	Performance (GPM@Head)				Shutoff		Cord Length (ft.)	Weight (lbs.)	Dimensions H x L x W (in.)
							5'	10'	15'	20'	Fl.	P.S.I.			
10E-CIM	511200	UL/CSA	1/2	115	3/4"	10.5/900	80	67	52	33	26	11.2	15	35	10.25 x 9.6 x 8.25
10E-CIA-RFS	511300	UL/CSA	1/2	115	3/4"	10.5/900	80	67	52	33	26	11.2	15	37	10.25 x 9.6 x 8.25
10E-CIM	511275	UL/CSA	1/2	208-230	3/4"	6.6A/900	80	67	52	33	26	11.2	15	36	10.25 x 9.6 x 8.25
10E-CIM	511225	UL/CSA	1/2	115	3/4"	10.5/900	80	67	52	33	26	11.2	25	36	10.25 x 9.6 x 8.25

All Models are 60 Hz (NOTE: Use 6.5 amps for 511275 for 50 Hz rating)
RFS = Mechanical Float Switch

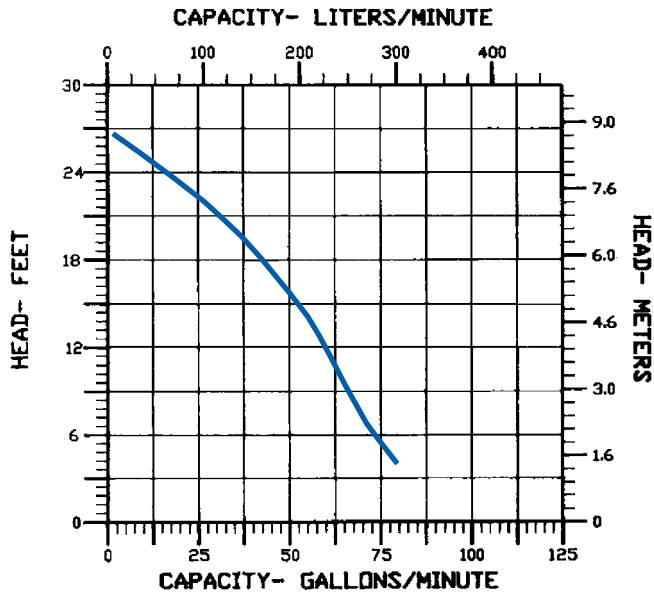

Construction

Motor Housing	Epoxy coated cast iron
Impeller Material	Nylon
Impeller Type	Volute
Volute	Epoxy coated cast iron
Power Cord	SJTW-A
Mechanical Shaft Seal	Nitrile with carbon and ceramic faces
Fasteners	Stainless steel
Shaft	Steel
Bearings	Upper and lower ball bearings